

DOCUMENT RESUME

ED 374 636

FL 800 770

AUTHOR Silliman, Anna
 TITLE Hands-On English, A Periodical for Teachers and Tutors of Adult English as a Second Language, 1991-1994.
 INSTITUTION Hands-on English, Crete, NE.
 REPORT NO ISSN-1056-2680
 PUB DATE 94
 NOTE 243p.
 AVAILABLE FROM Hands-on English, P.O. Box 256, Crete, NE 68333 (\$4 per copy; includes shipping).
 PUB TYPE Collected Works - Serials (022)
 JOURNAL CIT Hands-on English; v1-3 1991-1994

EDRS PRICE MF01/PC10 Plus Postage.
 DESCRIPTORS Adult Education; Body Language; Book Reviews; *Class Activities; Classroom Communication; *Classroom Techniques; Conversational Language Courses; Cultural Awareness; Daily Living Skills; Educational Strategies; *English (Second Language); Folk Culture; Games; Grammar; Grants; *Instructional Materials; Interpersonal Communication; Language Role; *Literacy Education; Multilevel Classes (Second Language Instruction); Puzzles; Reading Instruction; Recordkeeping; Student Records; Testing; Volunteers; Writing Instruction

ABSTRACT

These 18 issues of a newsletter designed for teachers and tutors of adult English as a Second Language, represent three volumes spanning the three-year period May/June 1991 through March/April 1994. Each issue contains brief articles, editorials, and materials reviews on classroom instruction, professional trends, and special projects. Typical content includes ideas for group work, notes on tools and techniques for instruction, grammar activities, cultural activities, reading activities, writing exercises, critiques of new books, texts, and instructional materials, discussions of classroom management and language-related issues, crossword puzzles and games, letters from readers, and classified ads and professional news. A combined index for the three volumes is included. (MSE) (Adjunct ERIC Clearinghouse on Literacy Education)

 * Reproductions supplied by EDRS are the best that can be made *
 * from the original document. *

ED 374 686

Hands-On English
A periodical for teachers and tutors of adult
English as a second language

Volume I, Number 1-6
Volume II, Number 1-6
Volume III, Number 1-6

PERMISSION TO REPRODUCE THIS
MATERIAL HAS BEEN GRANTED BY

Anna Silliman

TO THE EDUCATIONAL RESOURCES
INFORMATION CENTER (ERIC)."

U.S. DEPARTMENT OF EDUCATION
Office of Educational Research and Improvement
EDUCATIONAL RESOURCES INFORMATION
CENTER (ERIC)

This document has been reproduced as
received from the person or organization
originating it.
 Minor changes have been made to improve
reproduction quality.

• Points of view or opinions stated in this docu-
ment do not necessarily represent official
OERI position or policy.

FL 808 J 70



Hands-on English

A periodical for teachers and tutors of adult English as a second language

A helping hand for you

Our founding readers

Here is the very first issue—Volume I, Number 1—of a brand-new periodical that's meant to help you with your ESL teaching. Although our subscriber list is still small, we are proud to say that the response to our sample issue has been enthusiastic.

You, our first subscribers, are among the founders of *Hands-on English!* We're grateful for your interest, and hope that you will find us useful, whether you teach one student or many, in the classroom or out.

For adults only

You might ask: Why another ESL publication? There is a massive quantity of literature out there already, and we don't even have time to read that! As busy ESL professionals, we are almost overwhelmed by too much input.

First of all, we know of very few publications directed at people who teach adult ESL. And second, we know of nothing of a practical nature for adult ESL, by teachers of adult ESL. And, because it's a periodical, *Hands-on English* will keep on bringing you new ideas throughout the year.

Our goal

Much of what's available in print may be thoughtful, challenging, interesting, provoking, innovative and useful, even necessary, in the long view. But it doesn't help you get through tomorrow's lesson!

That's where *Hands-on English* wants to help you. We will be trying, six times a year, to send you activities you can try out with your ESL students. We deeply hope this will make your teaching easier and more fun.

Some of the activities we present will be innovative, some perhaps old standards, and some just, well, useful. For example, among other things in this issue we've got a word-find puzzle for you to copy and hand out to your students. There are three "strip stories" for a listening task your students will enjoy, and tips for creating your own. There are other activities both big and small for you to try.

A network

If you discover something that works, in the process of teaching adult ESL, share it with us! (There are some guidelines on page 6.) There are surely others who would like to hear about it.

Use *Hands-on English* as your network for exchanging practical teaching ideas with other teachers and tutors. 

Contents:

Group work	
—"Strip stories" for listening	2
Tools & techniques	
—Mapping for vocabulary	5
—"Scribes" help students learn	10
Information for Contributors	6
Idea file	
—Cartoon dialogs activity	7
Puzzle	
—a 4th-of-July word find	8
From the field	
—an American-style banquet	9
News & notes	11
On the market	
—a review of <i>Just-a-Minute</i>	12

Hands-on English (ISSN 1056-2680) is published six times a year (Jan./Feb., Mar./Apr., May/June, July/Aug., Sept./Oct., Nov./Dec) by Hands-on English, P.O. Box 589, Dewitt, NY 13214.

Copyright © 1991 Hands-on English

Subscription rates:

U.S.: \$16.00 for regular subscribers,
\$10.00 for volunteers or teacher's aides,
\$22.00 for libraries or institutions.
Canada and Mexico add \$4.; other
countries add \$10. Single copies may be
purchased at \$4.00 each.

Permission to photocopy: This periodical is copyrighted. However, we invite teachers and tutors who have a paid subscription (or whose institution has a paid subscription) to make as many copies as they need for their own classroom use.

Editor: Anna Silliman
(M.A., Teachers College, Columbia Univ.)
Contributing editor: Mary Jane Lucas

Address correspondence to the editor,
Hands-on English, P.O. Box 589, Dewitt,
NY 13214, USA.

Or, call the office at: (315) 445-0785.

Subscribe today!

Send this form with your check or money order (U.S. funds only) to the above address.

Send me a subscription to "Hands-on English."
I enclose:

- \$16.00 for a regular subscription
- \$10.00 for a volunteer or aide subscription
- \$22.00 for a library/institution

Name: _____

Address: _____

Institution: _____

Position: _____

**Group work:
"Strip stories" —**

Here's an activity known as "strip stories," in which a story is cut into strips and mixed. The students then reassemble the strips in the correct order. But, they have to do this by listening to each other!

Choosing the text

Use a story that is not too long. Even for an experienced group, 8 to 10 sentences is plenty. The sentences should have a clear progression, or should contain language clues to the correct order such as "first," "then," and "finally."

The text can be any story, problem, puzzle or explanation at an appropriate level for the students. The activity will be easier if the students already have some familiarity with the story. In fact, a strip story is a great way to review a reading from another lesson.

Setting it up

The activity works best with groups of 4, 5 or 6. Have the students sit in a circle. They won't need paper, pencils or dictionaries. Mix the story strips and hand them out. If there are too many strips, give some students two.

Instruct the students not to show their paper to anyone. Ask them to read their sentence to themselves and make sure they understand it. You can circulate and help with vocabulary and pronunciation, if necessary.

No fair peeking!

Now tell the group to put the story together. Remind them not to look at each other's papers (you may have to be firm about this). It might be helpful to demonstrate the 'read & look up' technique—students read their own paper silently, cover it with their hand and look up before speaking to the group.

The students can begin by reading their sentences aloud for the group one at a time, or the group can devise any other strategy. Once the group agrees on the correct order of the story, they read it to the teacher. If it's still not correct, they keep trying until they get it.

It can take from 5 to 20 minutes to solve the story, depending on the group and the complexity of the text. If you have several groups working at the same time, be sure to have an extra strip story ready in case one group finishes early.

- a challenging listening activity

Follow-up

A dictation is a great way to follow up this activity. Read the same story to the whole class, sentence by sentence. When they have finished writing, have the students correct the dictations within their groups. Each student can check the sentence he or she was responsible for in the speaking exercise. Or, the students can pass the strips around and correct their own papers.

Why it works

This is a problem-solving activity that students can do cooperatively, without the aid of the teacher. It generates intense listening, and focusses the students' attention on the connections between sentences and on the

meaning of the story as a whole. It can be fun, and satisfying to complete.

More stories

We include three examples of strip stories for you to try with your students. You can also create your own, by writing a 6- to 8-sentence summary of an article or story the students have already read.

For other examples, look in Richard Yorkey's Talk-a-tivities (Addison-Wesley, 1985) or in Index Card Games for ESL (Pro Lingua, 1982). For a whole book of strip stories for intermediate or advanced students, see Alice Blows a Fuse by John R. Boyd and Mary Ann Boyd (Prentice-Hall, 1980). ↗

Example 1. *This is a simple strip story in the past tense, with 8 sentences. Make a copy of this page for each group of students. Cut up into strips, mix and distribute.*

On Sunday morning I woke up at 11:00.

The first thing I did was drink a glass of water.

Then I took a shower and went out to buy a newspaper.

When I got back, I made some coffee.

While I drank my coffee, I read the paper.

I read the whole newspaper from cover to cover.

After that I had another cup of coffee.

Finally, I went back to bed and slept all afternoon.

Strip stories, continued from page 3

Example 2. *This strip story could be used as a follow-up, after the students have read Aesop's fable, "The Tortoise and the Hare." In that case, you might even ask the students to memorize their sentence before beginning the task.*

A turtle and a rabbit decided to have a race.

The rabbit was confident because he could run more quickly than the turtle.

So, halfway through the race, he stopped for dinner and then took a long nap.

The turtle, however, never stopped to eat or rest.

He went slowly but steadily forward until he crossed the finish line.

The rabbit couldn't believe his eyes when the turtle won the race!

Example 3. *Step-by-step instructions make very good strip stories. Try writing one about how to peel an apple, how to make tea, how to make eggrolls, or how to get a drivers' license—anything your students are interested in.*

Here's how to mix frozen orange juice.

First, open one end of the can.

Empty the can into a pitcher or a large jar.

Then add 3 cans of cold water.

Mix the water and juice together.

Finally, drink your orange juice!

Tools & techniques:

Mapping

Mapping, or "semantic mapping," is a useful technique for classroom, small groups or tutoring situations, with students at any level.

Karen Campbell, teacher in the Bilingual/Vocational Program for Vietnamese students in the Syracuse City Schools, Syracuse, N.Y., described this technique at the April Multicultural Education Conference in Syracuse, N.Y.

We know that the most effective language learning strategies involve linking new concepts to known, or familiar ones. "Mapping" is an excellent way to draw on the past experiences of the students, to categorize them and link them to new information. Mapping helps students to put new information or new vocabulary into a context they can comprehend. It is an easy technique to implement, and gets the students actively involved.

I often use the mapping technique when first starting a new unit. For example, we recently began studying the environment. To start with, I explained what 'environment' means. When the students understood the concept, I said "Now tell me some words that you know about the environment." They came up with many words—trees, lakes, rivers, etc.—which I wrote on the board, grouping the words by category.

The words they suggested in the brainstorming session show what the students' background information is, and how much English language they have on the subject of 'environment.' This tells me how well they understand the subject, and gives us the starting point for our lessons. From there, I could go on to introduce new concepts, gradually adding them to the map.

Similarly, we used mapping when we studied democracy. The technique helped us to compare and link the students' experiences of democracy with new concepts from readings, lectures and discussions.

Pre-reading activity

You could also use mapping as a pre-reading activity. For example, let's say the students were about to read an article on computers.

Divide the class into small groups, supplying each group with a large sheet of paper, and asking each group to choose a secretary. Ask the students to list as many words as they can on the topic of computers, in a given time (say 10 minutes), and to have the secretary write this list on the paper.

Next, the object is to create a large map of all the students' words, grouped into categories. You can tape up their lists on the wall. Ask the students: "What groups do you see here?" When they find a category, write those words in one area of the map, crossing them off the lists as you use them.

This can be a good exercise in categorizing things, but if the students have difficulty at first you could try suggesting a category and having the students decide which words fit into it. When complete, this map is a diagram of the students' combined knowledge of the subject. Students will be surprised at how much information they already have, and will be encouraged by seeing that large numbers of words can be grouped into just a few categories, making the mass of information less confusing.

At this point, they are ready to read the article about computers. Any new words from this article should be added to the map on the board. (Try using a different color for the new information.) Another option is to have each student maintain his or her own map. Grouping the new words into categories makes them easier to remember and understand. And, the map itself will help to explain new concepts by showing them in relationship with the old ones.

If you would like to read more about this technique, see the book Semantic Mapping by Joan E. Heimlich (International Reading Association, 1986). ↩

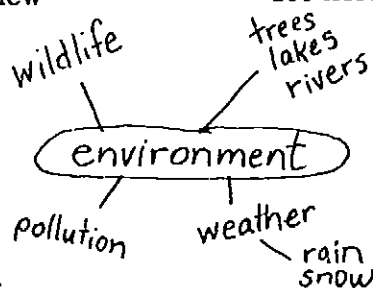

Information for Contributors

Hands-on English encourages submission of previously unpublished articles on topics of interest to teachers of English as a second language or as a foreign language, and to tutors of persons whose first language is other than English. The primary focus of the periodical is on practical teaching materials for teachers and tutors of adult ESL students. This audience might include part-time and full-time instructors in: adult education programs, intensive language programs, community colleges, refugee programs, literacy programs, prisons, workplaces or public schools. Within these programs, the students' English level can range from little or no English to very fluent, and from pre-literacy to college preparation.

The purpose of this publication is to provide instructors with practical, "hands-on" materials and ideas they can use in the classroom or apply to their students. We recognize that many adult programs are understaffed, underfunded and overcrowded, and want to provide the greatest possible benefit to instructors working under these conditions. We also recognize that the diversity of student backgrounds and needs in such programs often makes preparation for teaching very difficult. Therefore, an important criterion for the editorial staff in considering submissions will be how easily the suggested activity can be implemented, whether by new or experienced instructors.

Hands-on English will consider four kinds of submissions:

1. **Short articles**—from 200 to 500 words, clearly describing an original activity, exercise, game or technique, perhaps in step-by-step format, with a brief explanation as to the purpose of the activity, why it is useful and why it works. A student hand-out can be included, if appropriate.
2. **Reviews of books and products**—up to 250 words, describing practical materials such as student texts, games, tapes or other items of interest to our audience, perhaps with suggestions for using them.
3. **Hints and tips**—less than 150 words, clearly describing an activity, exercise, game or technique that has worked for the author, including a description of the kind of program and student population it was used for.
4. **News items, announcements and inquiries**—pertaining to ESL instruction.

Topics of interest to *Hands-on English* include: conversation and speaking fluency, reading, writing, listening, basic literacy skills, grammar, pronunciation, classroom management, multi-level classes, assessment and testing, among others.

The content of particular interest to *Hands-on English* includes activities that demonstrate: whole language learning, process writing, student-centered learning, group work, cooperative learning, student self-esteem, and multi-cultural understanding.

How to submit your contribution: Anything you submit to *Hands-on English* for consideration must be your own original work that has not been previously published, and is not under consideration for publication elsewhere. Send a typewritten copy of your work to Anna Silliman, editor, *Hands-on English*, P.O. Box 589, Dewitt, NY 13214. Include brief biographical information, your mailing address and a telephone number where you can be reached. Manuscripts submitted to *Hands-on English* cannot be returned, so be sure to keep a copy for yourself. All submissions, once published, become the property of *Hands-on English*. The editor of *Hands-on English* reserves the right to make changes to enhance clarity or style, but will consult the author if the editing is substantial.

Idea file



"Cartoon dialogs"

Here's a fun activity that involves speaking, listening, writing and reading. Almost any level of student can participate, and it works well with a multi-level group. It's actually a matching game in which students get to read each others' papers and match them with the right cartoon. It's more fun with lots of students, but works fine in a smaller group, too.

Use this activity with a new group to find out about the students' language level. It would also be a good lesson just for a change of pace, or even for a substitute teacher.

Preparation

You'll need a set of cartoon pictures, each one showing at least two people talking with each other. You can clip such cartoons from old magazines — the *New Yorker* is a good source, for example. Trim off the captions, and paste the cartoons onto pieces of tagboard. You now

have a durable teaching aid that can be used in many ways.

Idea file

Cut out the card below (you might want to make a photocopy, first). Tape or paste it to a 4x6 card. This way you can keep it handy, in case you need an activity on short notice.

You might want to file it in a card-file box that you keep on your desk. We've also included 'holes' in case you want to keep your cards in a ring-binder—they'll fit into a small binder for 4x6 cards, or even into a standard 3-ring binder. This is especially handy if you're one of the many adult-ESL teachers who has to travel from class to class!

Here's another hint—if you have a set of cards you'll be using during one session, get a single metal ring (available in stationery stores) and loop it through one of the holes in each card. Now you won't lose track of them, but they'll be easy to hold in your hand. 

"Cartoon dialogs" (matching game)

Purpose: Practice all skills; fun.
Level: Multi-level
Time: 45 - 60 minutes
Materials: Cartoon pictures mounted on cards.

1. Spread the cartoons out on a table.
2. Have students browse through the cartoons and choose one they like.
3. Ask the students to sit in pairs. Have them describe their pictures to each other orally. Give vocabulary help, if needed. (5 - 10 minutes)
4. Individual writing: Ask the students to imagine, "What are the people in your picture saying?" Give them 20 minutes to write down a conversation.
5. Have someone collect all the pictures, shuffle them and put them somewhere where they are easily visible.
6. Tell the students to put their names on their papers, then collect them. Mix the papers and distribute them to the students randomly.
8. Students should read the papers silently (give some discreet help if they have trouble reading each others' handwriting), then get up and try to select the matching cartoon. Have them check their answer with the author.
9. Repeat steps 5 through 8 as many times as you like.

Variations: Students read dialogs aloud to class in pairs, or act out dialogs; students rewrite the dialogs in teams; rewrite the dialog for homework; "publish" completed dialogs with cartoons in a notebook for the class to enjoy.

4th of July



Word find



A J P F F I R E W O R K S E P I S
 B K Q C G N T F Y Z O G P F O R H
 S F R E E D O M X A N O Q G A Q G
 U L S L H E U G W B M V R T A R F
 M A T E I P V U N C L E S A M T E
 M G U B J E A H V D D R T H E A D
 E M V R K N W T U A L N U C R X C
 R N W A L D X I R L K M V O I E B
 C O X T M E Y A T I V E W L C S J
 D B Y E N N P J S N O N X O A U J
 P I C N I C Z K R C T T D N N L U
 E R Z S O E A L Q O E Y C I L V L
 S T A T U E B O F L L I B E R T Y
 F H B R P S C M P N J A B S M W A
 G D C I U R W A S H I N G T O N Z
 H A D P S Q D N J E F F E R S O N
 I Y E E A G L E O F G B Z K L X Y



- | | |
|------------------|-----------------------|
| 1. America | 14. Lincoln |
| 2. bell | 15. parade |
| 3. birthday | 16. patriot |
| 4. celebrate | 17. picnic |
| 5. colonies | 18. stars |
| 6. eagle | 19. Statue of Liberty |
| 7. fireworks | 20. stripe |
| 8. flag | 21. summer |
| 9. freedom | 22. taxes |
| 10. government | 23. USA |
| 11. independence | 24. Uncle Sam |
| 12. Jefferson | 25. vote |
| 13. July | 26. Washington |



From the field

We are delighted to present this activity from Linda Thorington, ESL teacher at the Adult Basic Learning Center, Syracuse, N.Y. The banquet has a dignified and ceremonial quality that can only add to the self-esteem of the participants.



An American social event: The banquet

Linda Thorington's adult ESL class recently held an American-style banquet, with all the traditional hoopla—including speakers, presentations, toasts, photographs and a keynote address.

The occasion was to honor four of the students at the end of the school year. Three of them were leaving the class; one to a different school, one to a different city, and one to return to her country. The fourth was qualified to graduate but was planning to stay in the class to improve her writing skills.

A community of learners

For these four students, the event was a chance to receive recognition for their accomplishments, and encouragement for their future efforts. For the rest of the students, it was a summation of the year's work, a chance for reflection on what they had learned and, as Linda put it, "on the community of learners they had become."

Linda's class meets two evenings a week and includes people from Costa Rica, Italy, Jordan, Lebanon, Poland, Puerto Rico, Vietnam and Yugoslavia. The course emphasizes conversational skills, and Linda thought of holding a banquet when she realized that her students had had very little chance to write something and present it in a formal setting.

Preparation

The students had written a homework assignment about "Things I will always remember from the class," which they revised and practiced for their speeches. They discussed the social formalities of a banquet, tipping and how to order in a restaurant.

The teacher arranged for a room at a local restaurant, and helped to organize the sequence of events. She also typed up a program, which included the text of the four main speakers.

The event

When the banquet started, the tables were arranged in a U-shape, with a small table in front for a podium. Some of the students had brought family members. The speeches proceeded as planned, with the audience following along in the program.

One speaker talked of the good things that had happened to each student during the year. Another thanked the school, the teacher and the students for helping him to learn, not only English, but about other countries. The third speaker said of her fellow classmates, "I am not going to forget the times we shared together, we studied together and we helped each other. I will always remember you and feel happy to have been your friend."

Keynote address

The keynote speaker, who was being honored for her success in learning English, talked about how her attitude toward languages had changed. She said: "I accept the English language as it is! I never ask *why* some English rules are the same as in my own language and *why* some aren't. I think every language has its own unique beauty."

She advised her fellow students to always listen to people carefully, and to watch their body gestures and facial expressions. And finally she said that even if you learn only a few new words each day, you can say to yourself: "I did a great job!"

Following the speeches was a surprise for the teacher—a student presented her with some flowers. Then the departing three students were presented with small gifts that the others had arranged. There were toasts in English, and everyone learned a toast in Polish. Even the waiters got into it!

At the end of the evening, the students wrote autographs on the back of each other's programs, making them into very special souvenirs. ➡

Tools & techniques:

"Scribes" help students to learn



Linda Best is a teacher in the State University of New York at Geneseo's Language Skills Center. She has been using 'scribes' with ESL students there for several years. We recently interviewed her about this interesting technique.

The problem

ESL students are sometimes overwhelmed by the massive task of learning English. They tend to focus on what they can't do, and this can be discouraging. Because of this, many are reluctant to speak up in class. They are self-conscious and afraid of making mistakes.

We ESL teachers are always looking for ways to encourage students to take risks. But students often need a more personal, individual approach than we can provide in the classroom.

At the Language Skills Center at SUNY Geneseo, Linda Best has found a way to give students more individualized language feedback, support and encouragement, by using 'scribes.'

'Scribes' are sometimes volunteers from the school or community, and sometimes they are paid tutors. They work closely with an ESL student and have contact with the teacher as well. They attend class, and often also meet with the student outside of class.

How it's done

Each student, with the teacher, chooses a project to work on. The project might be to learn vocabulary and procedures at a supermarket, to learn to use a library, to visit an art gallery and discuss works of art, or to discuss opinions on a certain subject, or any other kind of project appropriate to the student's needs. It might also be a writing project or a presentation the student is working on. The scribe then helps the student to accomplish this specific goal.

A language notebook

The scribe's main function is to serve as note-taker for the student. He or she writes down what the student says, keeping a notebook of actual language samples. The student can then use this notebook to review vocabulary and get feedback on persistent

problems. The notebook is also used when conferencing with the classroom teacher. But most of all, the notebook makes the student aware of how much language he or she can produce—it's a confidence-builder.

What is the difference between a traditional tutor and a scribe? Linda explains that in an academic tutoring situation, often the burden of note-taking and recording falls on the student. In this system, however, the roles are reversed—the student is freed from the task of taking notes and can focus on communicating. The scribe functions as the recorder, but unlike a tape recorder, can also give feedback. In addition, whereas a tutor might function in a teaching role, the scribe is actually directed by the student and becomes a kind of assistant.

Scribes do receive some training at the Center, but Linda explains that teaching skills are not really what's needed in a scribe. Having good interpersonal skills, she says, as well as strong listening skills, are the only real requirements. A scribe's main job is to get the student to relax and talk.

Follow-up

The teacher will periodically ask to see the notebooks, or ask students to report on them. The notebooks are an integral part of student-teacher conferences—the students bring them along, with any questions they have, to the conference. The teacher generates lessons from the notebooks on things the students seem to need help with.

Lots of plusses

For the student, there are many advantages to working with a scribe. First, the scribe provides a language learning environment less stressful than the classroom. Second, the student gets personalized feedback. Third, the student gets help on a specific project. Fourth, the student gets a written record to study and refer to that reinforces the oral work. Finally, the student has a visual record of his or her own progress.

If you need a way to make learning more student-directed, and want to be able to

(continued, next page. . .)

Scribes, continued from page 10.

address individual needs of a variety of students, employing scribes might be the answer.

No money

What? Your program doesn't have a budget for paying scribes? Linda says there are plenty of ways to find volunteers:

- Other school staff may want to get involved
- Students in your school whose native language is English might be interested.
- Find volunteers from the community by contacting libraries, religious groups, etc.
- Literacy Volunteers of America (LVA) has programs nationwide. They might have tutors who are interested in working together with an ESL teacher.
- Students at local universities might like the experience.

Another approach might be to use peers in the class as scribes—Linda says she will be trying this technique herself, now that budgets are getting tighter. For example, two students might have a discussion, with a third student serving as scribe, recording their language.

The writing process

Scribes are valuable to students for their help in all aspects of language—speaking, listening, reading, pronunciation and others. One very important use of scribes, though, is helping students to brainstorm about their writing. Scribes can write down the general thoughts and responses of the student as they discuss the topic together. By relieving the student of the need to write things down at the initial stages, the scribe lets the student focus attention on the topic, not the form. Later, the notes the scribe has made can help the student to develop the ideas, organize them, and find the language for them. ➔

Coming soon:

Process writing

In coming issues Hands-on English will bring you ideas (from Linda Best, as well as other ESL teachers) to help your students gain confidence in their writing. We will focus on the concept of "process writing"—how to help your students with the writing process itself.

News & notes



Tutoring professionals?

A reader writes to us:

"I teach English to adults who are either professors, doctors or other professionals on a one-to-one basis. I would like to know what other teachers are doing in this area of teaching." Please write to:

Rosa Shattuck
8 Oriente #7
Cholula, Puebla MEXICO

(Hands-on English would also be interested in hearing from you on this issue. -Ed.) ➔

Memorable comment

CNN recently ran an item on a young Vietnamese woman who is overcoming the language barrier, a traumatic past and a speech handicap to become a very hard-working, successful high school student. When CNN asked her chemistry teacher about her, he smiled thoughtfully and said, "You know - she's become a real role model for me." ➔

Summer reading

If you have time to do some ESL reading this summer, you may want to see some lists of articles on topics relating to adult ESL and literacy. They are called "Minibibs" and are put out free by the National Clearinghouse on Literacy Education (NCLE).

To get a list of their materials, send a self-addressed, stamped envelope to:
National Clearinghouse on Literacy Education
Center for Applied Linguistics
1118 22nd Street NW
Washington, DC 20037 ➔

Puzzle key

Here's the key to the puzzle on page 8. ➔

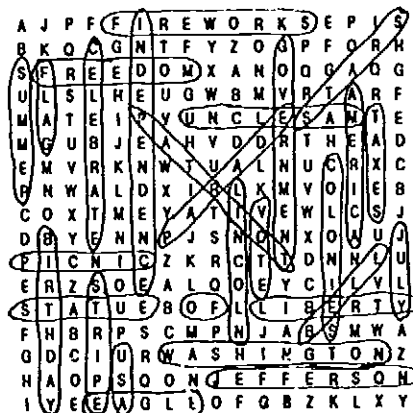

On the market

Reviews of useful ESL materials

"Just-a-Minute! The game that has them all talking" by Elizabeth Claire (1982, Eardley Publications) \$11.95.

In the never ending search for activities that work with multi-level ESL groups, this game is a find. It is easy to learn, and any student at the low-intermediate level of English and higher can play it.

Like the game "Password," one player tries to get others to guess a word by giving a description, an explanation, the opposite, or any hint he or she can think of. The topics and word lists in *Just-a-Minute* are designed for ESL learners, though, and cover a range of practical and useful everyday things.

The game includes instructions for team play, scoring and score sheets, but to be quite honest I have never used it in that way. The challenge of getting someone to guess a word correctly seems to be motivating enough for a very absorbing activity. My students have

generally played in pairs or in threes, for a 10- or 15- minute "filler" activity, and sometimes with enthusiasm for as long as 30 minutes.

The topics in the game (things in a house, things in school, body words, things to wear, etc.) are sometimes so basic that you might not think an advanced student would be challenged. On the contrary! The process of describing something for someone is difficult, and is one of the most important skills a non-native English speaker can learn. As I tell my students, no matter how much English you know, there will always be times when you don't know the word for something.

A multi-level, multi-cultural group is a good environment for learning this skill. Because of the difficulty in communicating among themselves, the students have to come up with various strategies to get their meaning across. Playing *Just-a-Minute* gives them specific practice in doing that.

— by Anna Silliman 

Hands-on English

A periodical for teachers and tutors of adult ESL

P.O. Box 589
Dewitt, NY 13214
USA

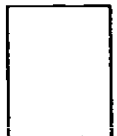



Hands-on English

A periodical for teachers and tutors of adult English as a second language

Teaching ideas for now—or later

We hope you're enjoying a good summer! Some of our readers are in the midst of busy summer sessions; others are resting up for their fall teaching. In either case, we think you will find this issue of *Hands-on English* a useful one.

Preparation

If you're taking some time to prepare ahead for ESL sessions in the fall, take a look at "Organizing all that ESL stuff" on page 4 for tips on getting your teaching materials in order. For a review of materials to supplement your teaching, don't miss "On the market" on page 2. Also, this issue's "Idea file" on page 9 might give you some ideas for planning lessons with a lot of mileage in them.

Use it now

If you're working with students right now, there is plenty of material here you can copy and use in your teaching. For example, your students may enjoy the "Religions crossword" on page 5, and some of the activities suggested. If you really want to get them communicating, take a look at the "Controversy cards" on page 11. And, there's a fun grammar activity on page 3 that will involve your whole group.

If you were intrigued by the concept of "mapping" presented in our last issue, you'll want to read on page 12 about making a 'story map' with your students.

New this issue

Finally we are excited to present to you "Process writing" —a new column appearing on page 8. This column should help tutors and teachers who are working with students on their writing skills.

In this issue's "Process writing" column, Linda Best offers her well-tested tool for helping students to assess and reflect on their own writing. We think you'll find it invaluable.

So, enjoy the rest of the summer, and happy teaching. And let us know how it's going—we want to be a helping hand for you! 

Contents:

On the market	
Review of "Whaddaya say?"	2
Grammar grab-bag	
A conversation activity using <i>if/would</i>	3
Cultural activity	
A religions crossword	4
Hints & tips	
Organizing all that ESL stuff	6
News & notes	7
Process writing	
Directing students to evaluate writing	8
Idea file	
Variations on a reading text	9
Group work	
"Controversy cards"	10
Tools & techniques	
More on "mapping"	12

Hands-on English

Volume 1, Number 2
July/August 1991

Hands-on English (ISSN 1056-2680) is published six times a year (Jan./Feb., March/April, May/June, July/Aug., Sept./Oct., Nov./Dec) by Hands-on English, P.O. Box 589, Dewitt, NY 13214 USA.

Copyright © 1991 Hands-on English

Subscription rates:

U.S.: \$16.00 for regular subscribers,
\$10.00 for volunteers or teacher's aides,
\$22.00 for libraries or institutions.
Canada and Mexico add \$4.; other countries
add \$10. Single copies may be purchased at
\$4.00 each.

Permission to photocopy: This periodical is copyrighted. However, we invite teachers and tutors who have a paid subscription (or whose institution has a paid subscription) to make as many copies as they need for their own classroom use.

Editor: Anna Silliman
(M.A., Teachers College, Columbia Univ.)
Contributing editor: Mary Jane Lucas

Address correspondence to the editor,
Hands-on English, P.O. Box 589,
Dewitt, NY 13214 USA.
Or, call the office at (315) 445-0785.

Subscribe today!

Send this form with your check or money order (U.S. funds only) to the above address.

Please send me a subscription to *Hands-on English*.
I enclose:

- \$16.00 for a regular subscription
 \$10.00 for a volunteer or aide subscription
 \$22.00 for a library/institution

Name: _____

Address: _____

Institution: _____

Position: _____

On the market

Reviews of useful ESL materials

"Whaddaya say? Guided Practice in Relaxed Spoken English" by Nina Weinstein (1982 Prentice-Hall Regents) \$8.00. ISBN 0-13-951708-1
Cassette tapes (2) \$32.00. ISBN 0-13-951716-2

This is not a new book, but it's still the clearest and simplest way I know to introduce intermediate and advanced students to "relaxed" or blended speech (such as *gonna*), especially because you don't have to be a linguist or an expert to do it.

One problem I have run into with students is the belief that blended speech is bad, sloppy, uneducated and wrong. In many languages, clear enunciation of each word is highly valued, whereas in English such enunciation by native speakers can sound affected or phony. Also, we English instructors tend to over-enunciate.

I tell my students that we like to blend words in English because it makes the sentences flow more smoothly in fast speech. I tell them they can hear blending not only in the workplace and on the street, but also at the university and in the White House. Yes, even the President of the United States says "*gonna*."

Each unit in "*Whaddaya say?*" introduces just one or two examples of blending, and can take 30 to 45 minutes to complete. It's fun to use the cassette tapes that accompany the book, but if you don't have the tapes you can easily present the material yourself by reading the examples aloud.

I generally found that once students had worked through five or six of the units and absorbed the concept, they didn't even need to complete the other units. What they learned made a huge difference in their ability to understand Americans speaking, and even TV.

I strongly agree with the premise of this book that ESL students don't need to learn to produce blended speech themselves. Americans will understand them just fine if they use careful, slow speech. It would be unnecessary for most students to learn blending, but learning to understand when Americans do it will help them a lot. 

Mail-order sources for ESL materials:

Alta Book Center	or	Delta Systems Co.
Burlingame, CA		Dundee, IL
1-800-ALTA/ESL		1-800-323-8270

Grammar



Let's start a business! (If... would construction)

Here's a fun conversation activity you can do with a multi-level group of students. It's especially good with students that know each other fairly well. And since it involves imaginary events, it gives the teacher the perfect opportunity to introduce or practice the *if... would* construction in context.

You could start by reviewing the many skills and talents of the people in the room. Suggest to the students that it would be nice if, instead of having an English class, the group could all start a business together. Ask them what business they would like to start, if they could.

Let the students develop an idea. One idea that often comes up first is to start a restaurant. Tell the students "If we start a restaurant, we will have to find a job for everybody." Encourage them to decide what needs doing, and who will do it. For example, will the restaurant also do catering? How about home deliveries? What kind of food will be served? Where will the fresh produce be purchased?

Continue the discussion until each student present has a job and the group is happy with the result.

Next, present the whole scenario the students have devised in writing, using the *if... would* construction. You could do this on the blackboard or overhead projector, or you could bring it in the next day on paper.

For example, "If we started a restaurant, Jaime would be the manager," etc. The students will enjoy reading this. The text will reinforce the vocabulary they used, and it will give you a chance to point out the grammar construction. If you continue the discussion further, encourage the students to try using *if... would* themselves.

Why It works

In a way, this is an exercise in self-esteem. Students will be pleased to have their abilities recognized, even for an imaginary event! It's also a great exercise for creating a friendly group spirit, even where students' English skill levels vary widely.



A funeral home?

To give you an idea how creative students can be, one ESL class decided to start a funeral home and found appropriate jobs for at least 12 people! Here's what they came up with:

"If we started a funeral home, Chou (an experienced driver) would be the driver. He would transport the body. Jerzy (a strong man) would help him to carry the casket. George (a construction engineer) would dig the grave.

"The teacher would be the receptionist, because her English is very good. She would talk with the customers. Mai Lou (a fashion designer) would design some clothes for the body. Farah (a nurse) would help to prepare the body and put on the clothes.

"Wojciech (a carpenter) would build a casket out of wood. He would also sing at the funeral, because he can sing the blues. Mai Chao (a good cook) would cook some food for the wake, and Huong (a student) would help to serve it.

"Hung (an electrician) would check the lights and appliances to make sure everything is working o.k. Maria (the most outgoing student) would talk to the guests to make them feel better.

"Lymay (mother of six children) needs a job—maybe she could be the manager." 

Cultural activity:

A religions crossword puzzle

Adult ESL students are often very interested in the subject of religions. There is a lot of material in this subject both for intercultural sharing and for learning about American culture.

How to use it

Here's a challenging crossword puzzle that includes vocabulary about many different religions. You can use this puzzle with your students in several ways:

- as a follow-up to discussions or exchanges you have had with the students about religions. A useful question to ask is: "What religions do you know about?"
- as a follow-up to reading, studying, or listening to news about current events such as the Mid-East situation, the trial of evangelists in the U.S., or any topic relating to religion.
- as an introduction to a cultural awareness unit on religions. Students could visit nearby places of worship, either as individual assignments or as a class trip, and report back.
- as practice in library research. You can help the students as they look for the answers to the puzzle in reference works.
- as an "information-gapping" exercise. Write each question, with the answer, on a 3x5 card. Distribute the cards to the students. Now each student has some information that the other students need. As they do the puzzle, give students a chance to ask each other for the information.

Follow-up

- Treasure hunt--You could write your own fill-in-the-blank exercise about religious activity in your community. For example: "There is a church across the street from the school. What kind of religion is it?" Students could take the worksheets with them and find the answers on signs, in the newspaper or telephone book.
- Word forms & categories study--Have the students try to fit the answers to the puzzle into the following categories: Name of religion, Adjective, Founder, Name of book(s), Place of worship, and Holidays. You could draw a chart of this information on the blackboard or large paper. Also fill in any information that was not in the puzzle.

Puzzle strategies:

- If you feel the puzzle might be too challenging, or the subject too unfamiliar for some of your students, you could offer them the Word List to refer to as they work.
- A hint--If your students are working without the Word List, you can point out to them that some of the answers will be found in other clues. This is a good reading technique to learn--finding the answers later in the text is quicker and easier than looking everything up.

Word list:

Bahai	Islam	pray
Bible	Jerusalem	priest
book	Jesus	Protestant
Buddha	Jewish	rabbi
Catholic	Koran	Ramadan
Christmas	minister	synagogue
church	Mohammed	temple
city	Moses	Torah
God	mosque	Veda
Hanukkah	New Testament	worship
Hindu	nun	
holy	Orthodox	
Imam	Pentacostal	

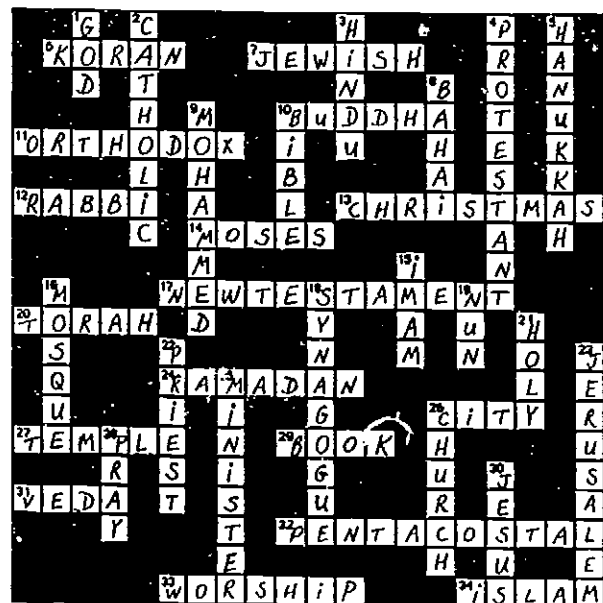

A crossword puzzle about:

Religions

Across clues

6. The holy book for the Moslem religion is called the _____.
7. Judaism is the religion of the _____ people.
10. The founder of Buddhism was called _____.
11. The _____ Eastern Church is the second largest Christian group in the world. It began in Eastern Europe and Asia.
12. The head of a Jewish religious group is called a _____.
13. _____ is a happy holiday for Christians, and others who like to celebrate it.
14. This man was an important leader of the Jews; he gave them their laws.
17. The Christian part of the Bible is called the _____.
20. The part of the Bible containing Jewish law is called the _____.
24. _____ is a time for fasting (not eating) for Moslems.
26. "Mecca" is a holy _____ for Moslems.
27. A building where Buddhists worship is usually called a _____.
29. The Koran is a holy _____ for Moslems.
31. A holy book for Hindus is called _____.
32. The _____ Church is a Protestant Christian group. Many people who belong to this religion are immigrating from the U.S.S.R. to the U.S.
33. People go to church, synagogue, temple or mosque to do this.
34. Moslems belong to a religion called _____.

Down clues

1. "Allah" is the Moslem word for _____.
2. The Pope is the leader of the Roman _____ Church.
3. The _____ religion is very important in India.
4. Many Christian groups that are not Catholic are called _____.
5. This holiday is a Festival of Lights for the Jews.
8. _____ Faith is a religious group that is not Jewish, Christian or Moslem. You can find it in the U.S. and the Mideast.
9. The founder of Islam was called _____.
10. This is a holy book for Jews and Christians
15. The head of a Moslem religious group is usually called an _____.
16. A building where Moslems worship is called a _____.
18. A building where Jews worship is called a _____.
19. A woman who has a special job in the Catholic Church is called a _____.
21. _____ is another word for "sacred."
22. The head of a Catholic religious group is called a _____.
23. This city in Israel is holy for many religions.
25. The head of a Protestant religious group is usually called a _____.
26. A building where Christians worship is called a _____.
28. When people speak to their God, they _____.
30. The founder of the Christian religion was called _____.

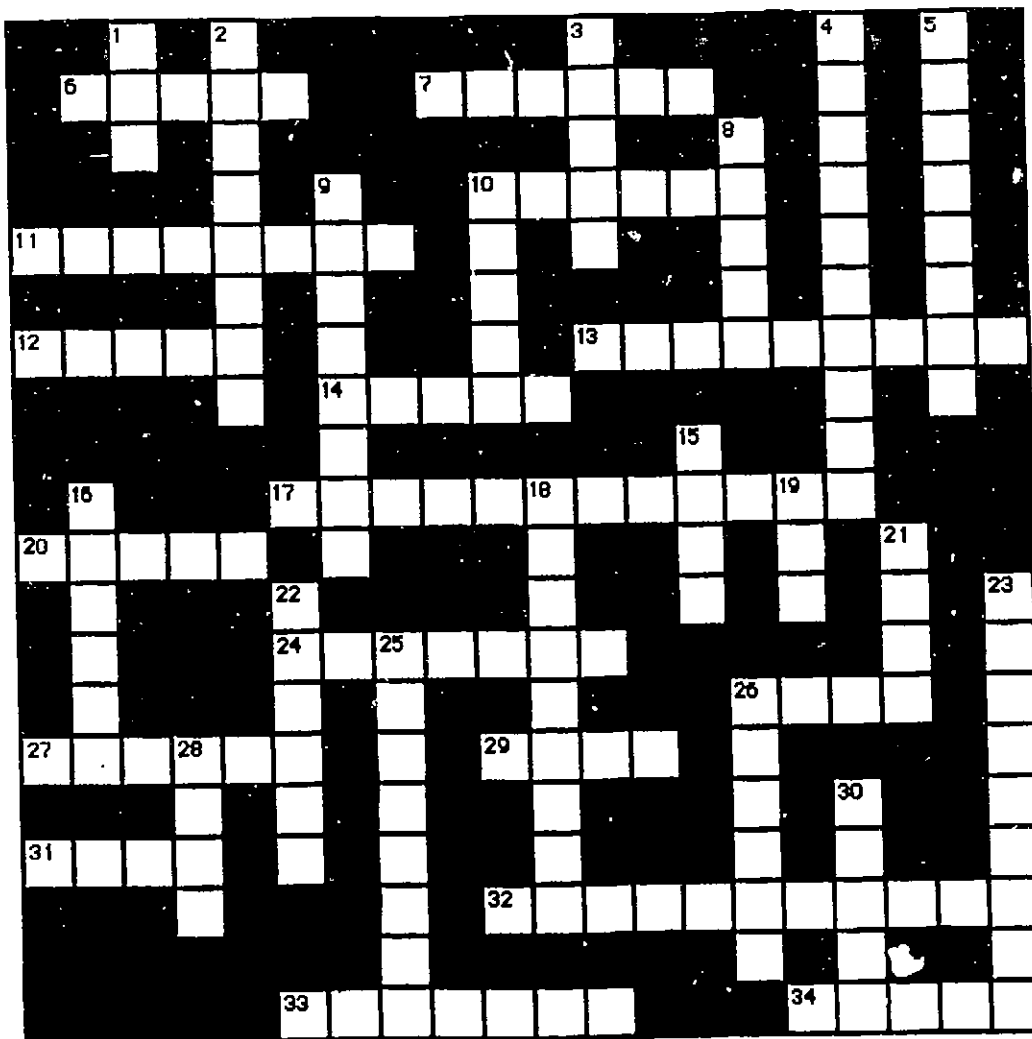

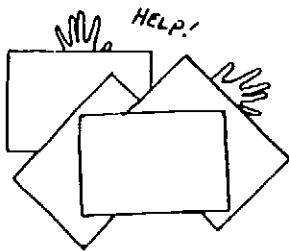

Hints & tips:

Organizing all that ESL stuff

Are you feeling guilty about piles of teaching materials that need sorting? Hate to think about those disorganized file drawers? Do you feel like a "pack rat" because you have so much stuff? Well, take heart—you are not alone.

What a mess!

We did some surveying of ESL professionals and discovered a very interesting fact. The dedicated ESL instructor rarely throws anything out. Why is this? We speculate it's because he or she understands that almost anything can, and does, turn out to be valuable for ESL learning.

Chaos and creativity

We see this, not as a character flaw, but as a great virtue reflecting an understanding of the complexity of learning and language. Out of the chaos of all of this stuff comes creativity in the classroom! Once you recognize this, you may not feel so bad about the quantities of things you collect for your teaching.

An additional problem for many of us in the adult field is that we rarely have our own classrooms or offices. Most of our stuff has to be carried around with us, and is probably stored at home.

To help you get a grip on all these things, *Hands-on English* has collected some organizing ideas, presented to you now in advance of the fall and a new teaching year.

One person's system

We first interviewed Mary Jane Lucas, who teaches ESL in the classroom, tutors students at different levels, and has the most incredible pile of stuff we've ever seen!

HOE: How do you organize all your ESL stuff? Is there a system?

Mary Jane: I organize materials on shelves (the 5-foot metal kind you can buy at K-Mart) using two systems—SKILLS (Listening, Speaking, Reading and Writing) and TOPICS (Holidays, American History, Grocery Shopping, Measuring, etc.) With each skill and topic I keep all the books, games, realia, props and tapes on that particular shelf so it's

all in one place. I use a 60% rule to determine where I put the materials. If the activity is 60% or more listening skill, it goes on the listening shelf. I use large ziplock plastic bags to keep the tape and book or printed material together. These I put in see-through magazine boxes to keep them from falling off the shelf.

HOE: Where can you get those magazine boxes?

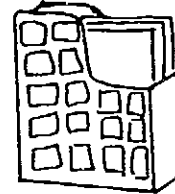

Mary Jane: The plastic ones you can get at stationery or office supply stores. There are cardboard ones, too. I think you can order them through library supply catalogs (ask a librarian).

My holiday materials are in large cardboard boxes with lids; the kind that reams of copy paper come in. I have separate boxes for each of the holidays. Most of my other files are in the filing cabinet, but for large categories I keep some file folders in milk-crate style boxes.

HOE: How do you store your other materials?

Mary Jane: Oversized decorations are in a huge box I made from a cardboard refrigerator box. Maps, charts, and newsprint are rolled up, labeled and stored upright in empty liquor boxes that have compartments in them. Arts and crafts supplies, including old magazines and pictures, are on another shelf. I also have a "Miscellaneous" shelf of stuff I'm not

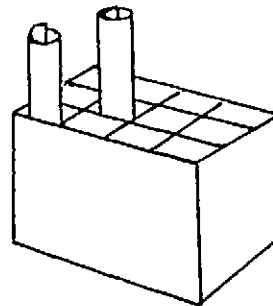

sure what to do with or that I'm giving away.

HOE: What's your biggest organizing problem?

Mary Jane: Keeping my files up-to-date. I started out using a computer print-out posted on the filing cabinet that listed all the folders, but I haven't kept up with it, or with my back filing. That's my summer project—file it or throw it out.

(continued, next page. . .)

Other tips

Hands-on English asked around for some other organizing tips and came up with these:

Tip #1—Use “Post-it” notes for indexing and cross-referencing. Anne V. Martin told us she attaches a “Post-it” note to the front of magazines containing articles of possible interest to her students. On the note she jots down the content of the article, saving lots of time looking for it later. She also uses these handy notes on the front of file folders to remind herself what other materials she has on the topic, and where they are located.

Tip #2—Several people we asked gave us this piece of advice: Set up a good filing system now, and it will save you time later. Painful advice, but no doubt true.

Tip #3—Are you organizing a workspace for yourself? We recently browsed through articles on creating a home office, and were dismayed at the pricey and streamlined suggestions offered. They just didn't seem suited to the necessary clutter of ESL.

If you need ideas, look instead to craftspeople for ways to organize a workspace—they understand clutter! Your local bookstore or library no doubt has a “how-to” section with books and magazines on woodworking, sewing, gardening, and other such messy crafts. They often give tips on organizing a workspace with an eye to economy and space efficiency.

Tip #4—To make your ESL life on the road a little easier, pack an “ESL survival kit.” Put in it anything you might possibly need for teaching such as: chalk, markers, overhead pens, extra pencils for students, 3x5 cards, masking tape, small scissors, and extra batteries and tapes (if you need them for a tape recorder).

As long as you carry your survival kit with you, you won't need to worry about missing supplies. ←

Share your ideas

If you have hints or tips on organizing, we'd love to hear from you! You may have just the tip we've been looking for.

News & notes



Books received

Hands-on English has received the following books:

- ♦ “A Manual of Structured Experiences for Cross-Cultural Learning” by the International Society for Intercultural Education, Training and Research (Intercultural Press, Inc.)
- ♦ “The ESL Miscellany, A treasury of cultural and linguistic information,” 2nd edition, by Clark, Moran & Burrows (1991 Pro Lingua Associates)

Look in future issues for reviews of these, and other works. ↗

Gee, thanks!

We've received a warm and enthusiastic response to the first issue of *Hands-on English*. To those readers who have responded, we'd like to say “Thank you!”

Let us know what we can do to make your teaching easier. ↗

The Year of the Goat

As you may know, 1991 is the year of the goat in the Chinese calendar. This traditional paper goat was hand cut by Jun Kong of the People's Republic of China.



Refugee Issues

Are U.S. refugee policies intended to keep immigrants in low-paying, marginal jobs?

For a fascinating, lengthy debate on the politics of refugee programs and refugee education, see “The Forum” in the *TESOL Quarterly*, Volume 24, Number 3 (Autumn 1990), pp. 529 - 555. ↗

Process writing:

Directing students to evaluate their own work



by Linda Best

Linda Best teaches at the Language Skills Center at the State University of New York at Geneseo.

One of the buzz-words in education today is *metacognition*—the act of reflecting about one's self. Most research suggests that this skill is ignored a great deal in formal education, which stresses the transmitting of information. This reflecting skill, however, is critical to learning, and especially to language learning.

To develop their metacognitive skills, students have to be directed to think about their work. Following popular 'problem-posing' techniques, I've worked to create checklists students can use either

independently, in collaboration with others, or in conferences with teachers.

The following questions are geared to generate self-reflection on the concepts stressed in a process writing course. The checklist could also serve other purposes, such as the assessment of listening and speaking skills.

Using the checklist, students usually jot down answers to the questions, then revise their papers accordingly. They read their own papers actively as they review the list, marking strengths and weaknesses and visually cueing the work for revision.

Through exercises like this, students can practice and develop their ability to monitor and assess their own work.

Student checklist

1. What is the main idea in this essay? Where do I state it?
Is it in an appropriate place?
2. Would a reader readily understand this idea, or do I need to give more information?
3. Do I emphasize the main idea enough, or should I mention it more frequently in the essay?
4. What is the strongest passage in this essay? Why?
5. Where does my essay seem weak? What is the problem? How might I resolve it?
6. What part of my essay do I like the most? Why?
7. What part of my essay am I not pleased with? How can I improve this section?
8. Where is my most effective language? Why are these words so appealing?
9. Where does my language seem dull or repetitious? Can I think of better ways to say what I wish, or should I work with someone else to improve these sections?
10. Do I organize my paragraphs well?
Is their relationship with the main idea clear?
11. Does each paragraph follow from the one preceding it?
What words establish the connection or flow?
Where are transitional words missing?
12. Do I explain or illustrate my major points well?
Where might the essay be unclear to a reader?



Idea file



Maximizing your materials—15 lessons in one

Are you getting enough mileage out of the ESL materials you use? We instructors are often guilty of rushing through material in an effort to make progress and keep things interesting for our students. In language learning, however, quantity doesn't always mean quality. Sometimes it can be more useful to work with one paragraph in 12 different ways, than to work with 12 different paragraphs.

Reinforcement

You can maximize your students' learning by approaching one short text in many ways, and using many kinds of exercises with that text. Returning repeatedly to the same text will give the students confidence and reinforce their learning. Yet, because each activity is a little different, the students will still be challenged.

Here are 15 activities you can do with one short reading passage, one or two paragraphs in length. They are listed in approximate order of difficulty, and can be adapted for any level of text or student.

Don't try to do all the activities at once. Choose a few, and spread them out over a period of 5 or 6 lessons. This will give the students a chance to absorb any new vocabulary or structures. By the time they're finished, the students should feel they've really got something under their belt.

What text to choose?

Any short text of interest to your students will do. We have found that passages with cultural information about the U.S. are very successful. Many ESL books offer such passages. Also try looking in newspapers and magazines, or public information brochures.

More Ideas?

Keep this handy list in a notebook or file, in case you need an idea on short notice. As you discover more ways to expand on a text, jot them on the back of the card so you'll remember to use them again. ↩

Variations on a reading text

1. Before reading the text, discuss the topic to find out what the students know.
2. Make a "semantic map"* of the vocabulary they already know.
3. Read the passage aloud, while the students listen only.
4. Have students read silently; discuss new vocabulary and add it to the map.
5. Have students form a question about each sentence in the text.
6. Read aloud, making one 'mistake' per sentence. (ie., change one word that alters the meaning of the sentence.) Have students correct you.
7. In small groups, have students retell the story. Use some visual cues for help.
8. If there is a new grammar point or a grammar focus in the story, have the students identify the instances of it. Give other examples; do some oral practice.
9. Cut the passage into sentence strips; have students reassemble them in order.
10. Cut a sentence into separate words; have students reassemble in order.
11. Have students write the story in another tense, change from singular to plural, or make other transformations that you specify.
12. Have students change the content of the story (ie. change the ending).
13. Write the text with some words missing; have students fill in the blanks.
14. Do a dictation of the whole text. Have the students correct their own papers.
15. Games: Use the new vocabulary for password, concentration, crosswords, etc.

*see p.12

Group work:

"Controversy cards"—a discussion activity

Many students are not comfortable voicing their opinions, or disagreeing with someone publicly. Sometimes the reason is cultural. The student may not know what kinds of disagreement are acceptable in our culture. Sometimes the reason is lack of confidence in the language—the student may be afraid of causing offense.

However, it can be very important for students to learn this skill, either for everyday survival or, in a college or university setting, for academic competence.

Here is an exercise that gives students some practice in voicing their opinions. By providing a structured and non-threatening context for agreeing and disagreeing, you can help students overcome their reluctance to do so.

Preparation

Choose some topics from the controversy cards on page 11 that you think your students will get involved with. Or, you can write your own. (If you need more ideas, there is a long list of discussion topics in "Conversation Inspirations for ESL" by Nancy Ellen Zelman (1986 Pro Lingua Associates).

This exercise involves both a speaking and a writing activity, and students at various levels can participate. For the speaking activity, put your students into groups of 3 or 4. It's best if they are sitting fairly close together and face-to-face.

Step one – talk about it

Now tell them that they will see a sentence. They will have 60 seconds to talk about this sentence, and they must tell the group whether they agree or disagree with it. You should actually model the language for them first, by writing on the board "I agree with this statement/I disagree with this statement."

After 60 seconds, they will be shown a new topic, to which they have to respond. Repeat this 6 or 7 times, or as many times as you think appropriate for your students.

You can display the sentences in one of two ways. If you're working with a large number of students, you might try showing the sentences one at a time on the overhead projector. When it's time to change topics, you could flash the light, or play some music to get

the students' attention.

Another way to manage this is to make a set of the topics cards for each group. You can circulate around the room, handing each group a card with the new topic. This allows for a little more flexibility in the time limit.

As the teacher, be careful not to get involved in the discussions at this point. This will inhibit the students from giving their own opinions. The point of this activity is to get the students warmed up and talking.

Now write about it

The second part of this activity is a writing exercise. Show the students all the topics cards at once. You can show them on the overhead, or have each group spread the cards on a table. Then ask each student to choose one topic to write about. Since they have already talked about these topics, they may have a good idea which one they are most interested in.

Ask the students to write, starting with "I agree with this statement because. . ." or "I disagree with this statement because. . ." Give them plenty of time to write—around 20 minutes. Students who finish up quickly might like to choose a second topic to write about.

Paper dialog

Collect the students' papers and then hand them out randomly. Ask the students to read the paper they've been given and to write an answer, starting with "I agree with you because. . ." or with "I disagree with you because. . ." When students finish writing a response, they should give the paper back to the original author, who can then make another written response, if time permits.

Circulate among the students to assist with any problems they have deciphering the handwriting. You can also help lower-level students to write their answers.

This written dialog is often very interesting. It can give the students a strong sense of each other's point of view, and a real feeling of interaction with one another. If the students want to, they can continue writing back and forth over the next few days.

A nice follow-up activity might be to have each student summarize orally for the rest of the class what the written argument was about. ➡

Controversy cards

Smoking should not be permitted in public places.	Children are better learners than adults.
Science is dangerous.	There is no way to stop terrorism.
Women should stay in the home.	Carrying a gun is a good way to protect yourself.
There will never be peace everywhere in the world.	Your family should approve of the person you marry.
Americans do not need to learn a foreign language.	People who believe in God are happier than people who don't.
Money is the most important thing in life.	The man should always pay when he takes a woman to dinner.

Tools & techniques:

More about 'mapping'

In our last issue we presented an article by Karen Campbell on 'mapping,' a simple device for helping students to organize the vocabulary they know into meaningful categories, and for presenting new vocabulary to students in categories they understand.

This is done by writing the topic on the board, asking students to recall any words they know on the subject, grouping these words into appropriate categories and listing them on the 'map.'

Because this is such a useful technique, with such profound consequences for student learning, we'd like to present yet another use for the technique, also suggested by Karen Campbell,—the story map.

Once your students have read or heard a story, ask them to help you describe the progression of events. As the students tell you what happened in the story, write the main events on the board. Use simple, brief sentences. For example, "Red Riding Hood leaves home" might be the first event in that

story. Next might come "RRH meets the wolf," then "The wolf eats grandma," etc. Under each event could come any details the students remember.

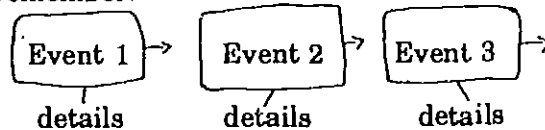

Once finished, this map is effectively an outline of the story, which becomes the basis for many class activities. For example, students can refer to the map to tell or write the story in their own words. They can use the map for grammar practice, such as writing the story in the past tense. Lower level students could try to write a sentence for each part of the story; beginners can copy from the board.

Why it works—This technique gives the students power and control over the text and the concepts in a story. Students at many different levels can participate together, making it a good whole-group activity. ↩



A periodical for teachers and tutors of adult ESL

P.O. Box 589
Dewitt, NY 13214
USA



Hands-on English

A periodical for teachers and tutors of adult English as a second language

Listening to history

During the last several weeks we've been hearing about some of the most exciting historical events to occur in the 20th century. If you are anything like us, radio and TV reports may have filled a lot of your spare time in August. Through the power of electronic media, we were wafted into the streets of Moscow and Leningrad, through the corridors of the Russian Parliament Building and onto the floor of the People's Congress.

Strange sounds

Our airwaves have been filled with foreign voices, to a greater extent than any other time in memory, some speaking Russian and many speaking English with Russian accents. It struck us as significant that at one point shortly after the coup, we stopped noticing the accents at all. We were too busy listening to what was happening.

Some of the interviews we heard were so intensely exciting that no one could possibly have cared whether the grammar, syntax, vocabulary, idiom, or pronunciation were correct or totally wrong—as long as we could find out what was going on!

News reporters, using excellent listening skills and enormous respect for their subjects, may have helped to create a tone of general acceptance for voices that sound "different."

As an example, we heard one radio interview with a man involved in Latvian government. He had some passionate things to say about what was happening in his country and how the United States might respond, and from his position in the government he had a unique perspective.

His English was no better than some of our low intermediate ESL students'. Yet the reporter truly listened, and where the meaning wasn't clear, quickly asked him for clarification, using phrases like "Do you mean that. . ." The result was a fascinating interview.

There are some lessons here for ESL teachers. Just like a reporter, can we listen to what our students say first, with language issues falling into second place in importance? It takes a powerful respect for the individual to do this, and a desire to truly understand him or her. But after all, if we work hard enough on meaning, the language will eventually take care of itself.

For a while anyway, it seems that on TV and radio, the old popular stereotype of a foreign accent reflecting stupidity or ignorance has dropped away. A Russian voice can be listened to with respect for what it is saying, not how it sounds. We are all broadened by this experience.

Contents:

On the market	
-a review of "The ESL Miscellany".....	2
Idea file	
-'Ice-breakers' for new students.....	3
Tools & techniques	
-The ESL student progress chart.....	6
Grammar grab-bag	
-'Here's what I want you to do'.....	8
Process writing	
-Freewriting with your students.....	9
News & notes	10
Dilemmas	
-a shy student.....	12

Hands-on English

Volume 1, Number 3
September/October 1991

Hands-on English (ISSN 1056-2680) is published six times a year (Jan./Feb., March/April, May/June, July/Aug., Sept./Oct., Nov./Dec) by Hands-on English, P.O. Box 589, Dewitt, NY 13214 USA.

Copyright © 1991 Hands-on English

Subscription rates:

U.S.: \$16.00 for regular subscribers,
\$10.00 for volunteers or teacher's aides,
\$22.00 for libraries or institutions.
Canada and Mexico add \$4.; other countries
add \$10. Single copies may be purchased at
\$4.00 each.

Permission to photocopy: This periodical is copyrighted. However, we invite teachers and tutors who have a paid subscription (or whose institution has a paid subscription) to make as many copies as they need for their own classroom use.

Editor: Anna Silliman
(M.A., Teachers College, Columbia Univ.)
Contributing editor: Mary Jane Lucas

Address correspondence to the editor,
Hands-on English, P.O. Box 589, Dewitt, NY
13214 USA.
Or, call the office at (315) 445-0785.

Subscribe today!

Send this form with your check or money order
(U.S. funds only) to the above address.

Send me a subscription to "Hands-on English."
I enclose:

- \$16.00 for a regular subscription
- \$10.00 for a volunteer or aide subscription
- \$22.00 for a library/institution

Name: _____

Address: _____

Institution: _____

Position: _____

On the market

Reviews of useful ESL materials

"The ESL Miscellany. A treasury of cultural and linguistic information." Revised, 2nd edition 1991 by Pro Lingua Associates. \$19.95. ISBN 0-086647-043-3

Do you create your own exercises for your ESL students? Do you make crosswords or other vocabulary games? Do you design your own course? Do you and your students get to choose which topics to study? Do you like to expand on the material that's in whatever textbooks you are using?

If you answered "yes" to any of the above questions, you may find The ESL Miscellany to be a very useful source of information for the work you are doing. It's basically a book of helpful lists—some about language (for example a list of grammar points that can be covered in an ESL course, lists of two-word verbs, word-roots, irregular verbs, etc., and lists of vocabulary and idioms about 10 situations and 60 topics of interest to ESL learners)—and some about American culture (for example immigration statistics, information on the U.S. government, presidents, entertainers, religions, proverbs and much more.)

There is so much information in this book that we couldn't possibly describe it all. It also includes a punctuation guide, spelling rules, abbreviations, and outline maps of the world. You could find most of this information, of course, in other reference works, but here it's neatly compiled in one volume and arranged with the needs of ESL teachers and learners in mind.

A unique feature of the book is the 20-page section on gestures and body-language that includes photographs and explanations. ESL students are often very interested in learning about this baffling, but important, part of our culture.

Best of all, the publisher encourages copying the material for classroom use, so you can legally make handouts for your students! We like this kind of teaching tool.

--by Anna Silliman

Mail-order sources for ESL materials:

Alta Book Center		Delta Systems Co
Burlingame, CA	or	Dundee, IL
1-800-ALTA/ESL		1-800-323-8270



"Ice-breakers"

Breaking the ice and getting to know each other, an important first step in any learning situation, is crucial in ESL. Language learners need a relaxed, friendly and supportive environment in order to learn. This is particularly true of adult ESL learners, in whom the tension level and the need to learn are often very high.

The greatest task of the instructor is to help to establish a friendly atmosphere, making it easier for everybody to communicate and to learn. In a multi-level adult group, this kind of environment doesn't always happen automatically. Building rapport between students takes some planning and some effort.

In this issue, we offer some activities that can help you and the students get to know each other better. This, we hope, will help you establish a supportive learning environment. The activities suggested will work with all

levels of students, and will work fine with a multi-level group.

One-minute conversations

This may be the simplest of all teaching devices, but it really works. It gives students a chance to communicate informally, but in a very structured, safe format. This can open up a lot of possibilities for better understanding, particularly between students who might not ordinarily sit down to chat together.

This activity can be repeated frequently, perhaps as a warm-up exercise from time to time. Use your own judgement in deciding whether the 'one minute' should be extended to 3, 5 or 10 minutes. Longer times generally work better when the students are more familiar with each other.

Note: For programs with open enrollment, this activity is a nice way to incorporate new students into an existing group, yet without the embarrassment that 'spotlighting' them can bring. ➡

One-minute conversations

Purpose: Ice-breaker, conversation
Level: Multi-level
Time: Flexible
Materials: A noise-maker for signalling

1. Divide the students into two groups, A and B.
2. Pair up the students, taking one from group A and one from group B.
(This can be done in two long lines, with group A facing group B, or in two large circles, with group A on the inside, facing group B on the outside. Or, the pairs can scatter around the room and sit together at tables.)
3. Make sure each student identifies his or her partner.
4. Tell the students they will have one minute to talk with their partners, and that during that time they can discuss anything they want. Announce "start."
5. At the end of one minute, signal time to stop, using a bell, noise-maker or music.
6. Ask the students in group A to say goodbye to their partners and move on to the next person on the right.
7. When everyone has a new partner, signal the start of the next one-minute conversation.
8. Repeat several times, until each student has had several conversations.

Variation: As a warm-up exercise, assign each student a partner—someone they rarely work with. Announce a 3-minute time limit and let them converse.

Ask me

This idea was contributed by Judith Dancoff, ESL teacher in Los Angeles, CA.

Here's an ice-breaker that lets the students get to know the teacher better, and helps the teacher to get a sense of the language level of her new students.

Ask me

Purpose: Ice-breaker
Level: Multi-level
Time: 45-60 minutes, depending on the size of the group
Materials: 3x5 cards

1. Hand the students some blank 3x5 cards, and tell them they will have a chance to ask some questions about the teacher.
2. Ask them to write one question on a card. If the group is small, students may write more than one question.
3. Collect the cards.
4. Go through the cards, reading each question aloud, and making some response to each one. (If students want to ask more questions orally, this is o.k. too.)
5. Ask the students to take out paper and pencil for a dictation.
6. Choose 10 of the cards and read the questions for the students to write.
7. Put the questions on an overhead transparency, or on the blackboard.
8. Have students mark their own errors; collect the papers.
9. Now ask the students to interview each other in groups of 2 or 3, using the same ten questions as a starting point.
10. If time permits, have them write something about the person they interviewed, or report orally to the class. ➡

'Find someone. . . ' questionnaire

This is a popular exercise among ESL teachers. It is a student-centered activity that involves a lot of moving around and talking, and it's a great way for students to get to know each other a little better.

Customize your own

The example questionnaire on page 5 is a basic one that might work with any group of students. But, if you are already a little bit familiar with your students, you can write your own version that includes information you know about them. For example, if you happen to know one of your students has six children, write "Find someone who has six children" on your questionnaire. This can make the exercise much more interesting.

If you write your own, keep in mind that some students may be disappointed if their name is not included as one of the answers. If your class is large, you could solve this by having multiple answers: "Find three people who come from China," for example.



The structure practiced here is question forms. You may have to remind your students, by writing a sample question on the board, of the word order in a question. (ie, "Do you like to sing?")

If your students are beginners, you could rewrite the questionnaire using direct questions (ie, "Who likes to sing?" and "Who has a driver's license?") making the exercise a little more straightforward.

How to do it

Give each student a copy of the questionnaire. Explain to the group that the purpose of the exercise is to practice asking questions.

Tell them they will have some time (20 or 30 minutes, depending on how many questions there are) to find the answers. Encourage them to move around the room and talk to each other.

Follow-up— When most of the students have completed the questionnaires, bring the group together to report on the answers. ➡

Questionnaire

Talk to the other students. Ask them these questions, then write the answers on your paper.

1. Find someone who likes to sing. _____
2. Find someone who has a driver's license. _____
3. Find someone who has a child in school. _____
4. Find someone who likes cold weather. _____
5. Find someone who has been in this country more than one year. _____
6. Find someone who is good at math. _____
7. Find someone who has a photograph here today. _____
8. Find someone who doesn't like to cook. _____
9. Find someone who can speak three languages. _____
10. Find someone who is interested in computers. _____
11. Find someone who has a houseplant at home. _____
12. Find someone who was born in January. _____
13. Find someone who has a job now. _____
14. Find someone who likes to watch TV. _____

Tools & techniques: ESL student progress chart

—an informal assessment tool

You can use this chart to quickly evaluate new students' skill levels. Once the system is in place, you can use it to give your students individualized feedback when you talk to them in periodic interviews--without spending a lot of preparation time. Or, if a student has a question about his or her progress, you'll have a simple and clear way to talk to him or her about it, using this chart.

In addition, your students will give you feedback about their needs, strengths and weaknesses that will help you in planning your teaching.

How to do it

Take a look at the chart to make sure the levels described apply to your students. If not, go ahead and make changes on the chart. (The values on the chart aren't absolute—they are only relative to your students.) If your program uses any testing tools for placement or assessment, you could write the appropriate scores in each box. Remember, though—this is an informal measure of student progress. You don't necessarily have to use test scores.

Make copies of the chart, and put one in each student's folder. As you get to know each student, through class work, testing, interviews, writing samples, etc., take a guess as to which levels their skills fall into. On the chart, simply draw a circle around the most appropriate description for that student in each skill area. The levels will probably vary from skill to skill. Try to do this as soon as possible with new students—preferably during their first week!

Here's an example of what the chart will look like as you work with a student:

ESL student progress chart: an informal assessment tool

Name: *Maria* Last update: *9/8*

Specific Skills	Accumulation	Listening	Reading	Vocabulary	Writing	Grammar
6 Understand and follow directions	Understands and follows directions	Understands and follows directions	Understands and follows directions	Understands and follows directions	Understands and follows directions	Understands and follows directions
5 Understand and follow directions with some assistance	Understands and follows directions with some assistance	Understands and follows directions with some assistance	Understands and follows directions with some assistance	Understands and follows directions with some assistance	Understands and follows directions with some assistance	Understands and follows directions with some assistance
4 Understand and follow directions with frequent assistance	Understands and follows directions with frequent assistance	Understands and follows directions with frequent assistance	Understands and follows directions with frequent assistance	Understands and follows directions with frequent assistance	Understands and follows directions with frequent assistance	Understands and follows directions with frequent assistance
3 Understand and follow directions with some assistance	Understands and follows directions with some assistance	Understands and follows directions with some assistance	Understands and follows directions with some assistance	Understands and follows directions with some assistance	Understands and follows directions with some assistance	Understands and follows directions with some assistance
2 Understand and follow directions with frequent assistance	Understands and follows directions with frequent assistance	Understands and follows directions with frequent assistance	Understands and follows directions with frequent assistance	Understands and follows directions with frequent assistance	Understands and follows directions with frequent assistance	Understands and follows directions with frequent assistance
1 Understand and follow directions with constant assistance	Understands and follows directions with constant assistance	Understands and follows directions with constant assistance	Understands and follows directions with constant assistance	Understands and follows directions with constant assistance	Understands and follows directions with constant assistance	Understands and follows directions with constant assistance

Ready for feedback

Now, when you meet with each individual student, you are ready to talk about his or her English skills in a very specific way. Show the chart, and explain briefly that all seven areas are important in learning English. Ask the student to tell you which skills are most important for him or her, and why, and take notes on what the student says right on the chart. This will help you to discover the student's goals, learning strategies and needs. You can even do some planning with the student about how these needs will be addressed in the class.

This kind of interview shouldn't take too much time—usually only a few minutes—but it will yield a lot of useful information for both teacher and student.

Keep this chart in the student's folder, and refer to it any time questions come up about progress, course work and learning strategies. If you meet with each student at regular intervals, spend a few minutes going over the chart point by point to see what progress has been made, and mark it on the chart.

Why it works

Using this chart, there is almost always something positive to say to your students. They will see visual evidence of their progress, which can be a real confidence booster. Further, it will help the students focus on the areas that need work without getting too discouraged.

Most of all, this careful individual attention shows each student how concerned you, the teacher, are about their learning process. Using the chart will start you off with an excellent working relationship.

Keep in touch

We'd love to hear how the progress chart is working for you and your students. We'll be printing a questionnaire in a few months to get your feedback.

Any questions or comments? Write to us, or call the office at 315-445-0785. Thanks! 

ESL student progress chart: an informal assessment tool

Copyright © 1991 Hands-on English

Name _____

Last update _____

Speaking fluency	Pronunciation	Listening	Reading	Vocabulary	Writing	Grammar
Speech is smooth and effortless	nearly accentless pronunciation	understands even lectures and discussions; takes dictation from unfamiliar text	understands most material; sometimes uses dictionary	idiomatic and extensive	clear expression of ideas with some formal organization	uses advanced structures
Speech is sometimes hesitant, but generally smooth; less fluent than native speaker	has an accent, but no important mispronunciations	understands nearly everything in normal conversation; some difficulty with TV or lectures; no words missing or misheard in dictation on familiar text	understands most material with frequent use of dictionary and some questions	usually appropriate and descriptive	expresses ideas with supportive argument; errors do not obscure meaning	uses some advanced structures
some hesitation; often rephrases or searches for words	usually can be understood; accent and mispronunciations do not interfere	understands normal speech on familiar topics with occasional repetition; meaning is clear in dictation on familiar text	reads unadapted material, but only with help of dictionary and native speaker	generally appropriate; paraphrases when lacking words	expresses own ideas with effective, complex sentences; errors usually do not obscure meaning	uses intermediate structures; some knowledge of advanced structures
hesitant; pausing often disrupts conversation	accent requires careful listening; sometimes leads to misunderstanding	understands careful speech on familiar topics at slower speed; some repetitions needed; meaning fairly clear in dictation, some words missing	usually reads adapted ESL materials	self-expression is limited by vocab; makes some use of all-English dictionary	writes some complex sentences; expresses some of own ideas; errors occasionally obscure meaning	uses some intermediate structures
speech is slow, hesitant and uneven; some silences necessary	pronunciation very difficult to understand; must repeat frequently	understands only slow, simple speech on familiar topics; requires repetition; lots of words missing, meaning unclear in dictation	reads controlled dialogues and sentences	basic only; uses bilingual dictionary	writes simple sentences; errors frequently obscure meaning	uses beginning structures; some knowledge of intermediate structures
speech is very halting; conversation almost impossible	often unintelligible, even with repeats	understands too little for simple conversation; doesn't take dictation yet	reads basic dialogues and simple sentences only	lack of vocabulary prevents functioning	writes basic sentences only; errors obscure meaning	some knowledge of beginning structures

6

5

4

3

2

1

33

34

Grammar grab-bag

"Here's what I want you to do..."

want + object + infinitive

Power language

Here's a unique grammar exercise that offers your students a chance to play a competent, adult role while learning a useful and sophisticated sentence structure.

It's probably best for intermediate students, who are starting to use complex sentences. They should already be familiar with the verb + infinitive structure (ie, *I want to go, I hope to win, She expects me to arrive*, etc.)

Preparation

Introduce the new structure by giving several examples of what you generally expect your students to do. For example, "I want my students to speak English in class."

Put one of these examples on the board, circling the three structural components, *want*, object and infinitive, and discuss them.

Have the students try out the structure by reviewing what you said. For example, "The teacher wants us to..."

If you feel your students need more practice with this structure, try this three-person drill:
Teacher: Hung, please tell Jaime to open the window.

Hung: Jaime, the teacher wants you to open the window. **Jaime:** OK.

Do as many examples as you need to until your students are comfortable with this.

The exercise

Explain to the students that they will each be given a very important job. Hand out a job card to each student, announcing his or her position to the class. For example, "Jaime, you are the police chief." (You can choose from the prominent positions listed below, or write others more appropriate for your students.)

Tell the students they will meet with their 'employees' in about 20 minutes to tell them what to do. They must write a list of instructions to be given at the meeting. Let them know in advance how many 'employees' they will be speaking to. (If you have more than eight students present, divide the class into groups no larger than about eight each.)

While the students are preparing this list, you can circulate and offer assistance.



The meeting

Call the students to a meeting. This is most effective if done around a large table, or group of tables pushed together. Ask one person to stand at the head of the table to give instructions. Set the scene by introducing the speaker in a formal manner, giving his or her position. Clearly state to the other students what role they are playing at this point.

To assist the speaker, make sure you have written the grammar structure on the board: "I want you to ____" so he or she can refer to it if necessary.

Give each student a turn at the head of the table, making an introduction each time to set the scene. ➡

Job cards:

- | |
|---|
| You are the director of a school.
You want the teachers to: _____ |
| You are the police chief.
You want your officers to: _____ |
| You are the mayor of this city.
You want your assistants to: _____ |
| You are the fire chief.
You want the fire fighters to: _____ |
| You are the teacher.
You want your students to: _____ |
| You are the head of a big company that makes air conditioners.
You want your employees to: _____ |
| You are the director of a big hospital.
You want your employees to: _____ |
| You are the president of a university.
You want your staff to: _____ |
| You are the mother of 12 children.
You want them to: _____ |
| You are the President of the U.S.
You want your Cabinet to: _____ |
| You are the manager of a busy restaurant.
You want your employees to: _____ |
| You are the editor of a big newspaper.
You want your staff to: _____ |



Process writing: 'Freewriting' — getting the ideas out

by Linda Best, Instructor at the State University of New York at Geneseo, Language Skills Center.

Student writers, particularly ESL students who are overly concerned with grammar, often approach writing in a linear manner. They write, review and make minor changes and think they've finished writing at this point. But they still haven't attended to important features of writing such as coherence and the development of ideas.

Today, research into the writing process emphasizes that it is recursive. That is, real writers actually move forwards and backwards as they compose, from thinking about ideas, to organizing, to revising, to thinking again, and to editing. They juggle all of these processes as they go.

Modeling for students

To help students learn to explore ideas, rather than focus on producing finished essays, I model the writing process for students in class. I participate in the activity because inexperienced writers who write in a linear fashion often don't know what to do with the ideas they generate. Several 'invention' techniques, including freewriting, can help them with this.

Freewriting

We begin by listing and discussing briefly some topics for writing. Everyone has input, so that the topics suit the class. Each individual 'freewrites' for 5-8 minutes on one particular topic. The object is to find where our ideas will go rather than to feel constrained by a topic.

I do my freewriting on a transparency since I will be using it for instruction as well. After the first freewriting segment, we review what we wrote silently, reading to get in touch with our ideas and to identify a main idea. We underline or jot this down.

We proceed to write on the same topic again, for 5-8 minutes. Having reflected on the first segment, our thinking is triggered and re-directed. Once again, we write, review, and jot down a main idea. We are simultaneously exploring and shaping the thoughts we have on a given subject.

Group feedback

This freewriting exercise gives everyone some material to work with. I next model how a writer might use the material to prepare an essay. I place my transparencies on the overhead and read my work to the students. I ask them to direct me to strong ideas, to irrelevant ideas, to effective language, and to the passages which aren't developed.

Offering feedback, my students are thinking critically, forcing me to appraise my work from a reader's perspective and thus directing my efforts to organize it.

My students then do the same with their own material, either in class, with tutors, or in student-teacher conferences. For several sessions, we work on the material we generated. In small groups or as a class, we discuss and present our material as it's taking shape. Our understanding of what we wish to convey is sharpened continually by the class's responses and questions.

Why it works

The exercise is beneficial for a variety of reasons. During the critical stage of developing their ideas, it removes students from worries about grammar, which can interfere with their thinking. Also, students observe, through my work and my response to their comments, the recursive nature of the writing process. ←

Tips

for writing with your students:

1. Use lots of brainstorming and talking first!
2. Work on ideas, before working on writing.
3. Use 'freewriting' to get some ideas out on paper (see above article).
4. Show your students how to write—participate!
5. Read things aloud to see how they sound.
6. Don't be afraid to change things around.
7. Think of writing as experimenting!

News & notes

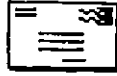

Upcoming conferences

Three (inter)national conferences in the next few months:

♦ **October 14-20, 1991**—American Association for Adult and Continuing Education (AAACE) in Montreal, Quebec, Canada.

♦ **November 14-16, 1991**—Literacy Volunteers of America (LVA) in Orlando, Florida.

♦ **March 3-7, 1992**—Teachers of English to Speakers of Other Languages (TESOL) in Vancouver, British Columbia, Canada.

Facts on Refugees

The "Refugee Concerns" Interest Section Newsletter from TESOL reports that the number of refugees worldwide for 1990 was at least 16 million. This number is unfortunately growing. 122,000 refugees entered the U.S. last year, double the number entering in 1985.

With resources for resettlement costs dwindling, though, the concern is that programs will not be able to offer enough assistance to help refugees become self-sufficient. (Language training is one factor, as well as cultural adjustment and vocational training.)

Congress is currently debating appropriations for refugee resettlement. You can write to your Senators and to your Representative in Congress, urging that they reauthorize the Refugee Act of 1980, and that they give it adequate funding.

Books received

Hands-on English has received the following book:

"Crossroads 1" by Irene Frankel and Cliff Meyers (1991 Oxford University Press).

Look in future issues for reviews of this, and other works.

Help! Which tests to use?

Several people have written to us, asking for information about placement tests for adult ESL programs.

If you use a test you can recommend for this purpose, drop us a line and tell us about it. We'll try to discuss these tests in our November issue. Thanks!

Signs of the times

Visitors to the moors in England can now find their way with the help of some new signposts--in Japanese. Tastefully engraved in wood, they seem to fit right into the landscape.

Astounding fact

Hands-on English now has subscribers in 28 states! Word seems to be spreading quickly.

Gift shopping?

"Save the Children," a non profit organization, has a holiday catalog with gift items, ornaments and cards with an international flavor. Purchases benefit children in the U.S. and 37 countries worldwide. Call 1-800-833-3154.

New members to the United Nations

Recently admitted to the U.N. as new members were: North and South Korea, Latvia, Lithuania, Estonia, the Marshall Islands and Micronesia. But we're not buying a new atlas quite yet!

Hints & tips:

Conversation starters

Tutors, take note! The National Geographic magazine can provide a nice way to start a small-group discussion. Students often have a lot to say about the stunning photographs, especially when they know something about the topic and can explain it to other students.

For example, we found a back issue with a story on Hungary, and asked our Hungarian students to explain the pictures. They did so enthusiastically. The other students were curious and asked a lot of questions. This type of sharing is easy to relate to.

In case your attic isn't already full of them, used book stores often sell back issues of the National Geographic. If you meet in a library, of course, you can make use of the magazines available there. For specific topics, look in the 100-year index that National Geographic put out in 1988.

**Alex Haley will be at
LVA Conference '91 in
Orlando, Florida... Will You?**

*The 1991 Literacy Volunteers of America National
Conference will be bigger and better than ever!*



Features:

- Keynote address by author, Alex Haley.
- 80+ Workshops presenting a range of Basic Literacy and ESL issues and instruction for trainers, tutors and program managers.
- Technology Lab demonstrating the latest in literacy management and educational software!
- Publisher's Exhibits featuring current materials available from a broad range of educational publishers.
- Lots of fun and entertainment including the LVA Banquet, excursions to area sights and Dixieland Music.
- Special rates for early registration (pre Oct. 11)! Write or call LVA for details! 5795 Widewaters Parkway, Syracuse, NY 13214 (315) 445-8000.



**Conference '91 - November 14-16
Literacy Volunteers of America, Inc.**

Maybe.

Maybe you didn't know Literacy Volunteers of America, Inc. produces and carries a full line of ESL training and tutor/student materials.

Maybe you did.

Maybe you'd like to know more.

Let us send you a free 1991-1992 LVA Materials and Services Catalog.

Call or write us: LVA 5795 Widewaters Parkway, Syracuse, NY 13214. (315) 445-8000.



**All About
Language**

**Books that teach
vocabulary,
structure, and
discourse of
common themes**

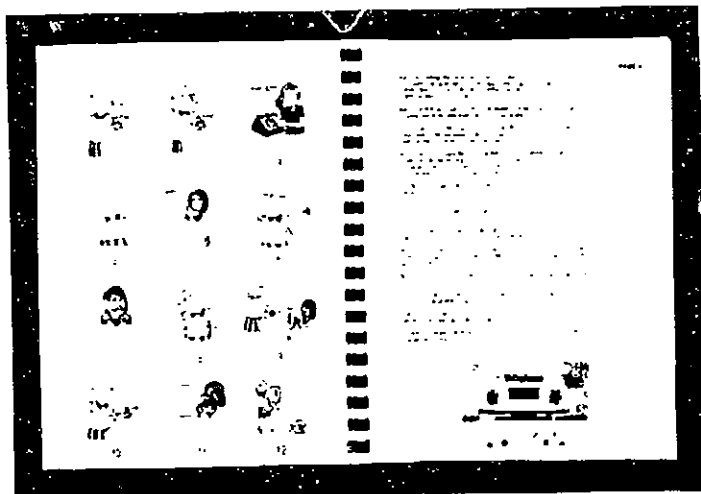

• COMMON THEMES

Now available are TELEPHONE, TRANSPORTATION, BUSINESS, WEATHER, HOUSES AND BUILDINGS, POST OFFICE, ENTERTAINMENT, and SCHOOL.

• PICTURES, TEXT, AND AUDIO-CASSETTES

Each book contains text, coordinated pictures, and an accompanying audio-cassette.

WRITE FOR CATALOGUE OR CALL
TOLL FREE 1-800-237-1837



International Linguistics Corporation

3505 East Red Bridge • Kansas City, MO 64137

38

Dilemmas

We welcome your questions about ESL teaching dilemmas. Maybe we have an idea that can help, and if not, we can try to find someone who does. So drop us a line and let us know what you're concerned about!

Dear *Hands-on English*,

Do you have some ideas about working with a very shy student in my class? Thanks.
K.L., Waco, Texas

This really can be a dilemma, since the nature of language classes often requires students to be outgoing in order to succeed. We need to think of ways to help your student become successful, but within the parameters of his or her personality. Here are some ideas:

- Vary the format of your class to include lots of small-group work. Often a 'shy' student is really just uncomfortable performing for the teacher, and will do much better when not under direct scrutiny.
- Be patient, and don't hassle the student about participating. Some students need a lot

of extra time before they feel ready to jump in, even weeks or months!

- In the meantime, make sure the student knows you haven't forgotten about him or her—make contact in a non-threatening way, such as chatting after class, or including a note with some homework you're handing back. Let the student know in a quiet way that you notice when he or she is doing well.
- Don't be afraid to ask the student (privately) if something about the class bothers him or her. There may actually be a problem that you can do something about.
- If the student isn't speaking very much, find out what other language strengths the student does have. You can use the progress chart (page 6 & 7) to focus on strengths, and to encourage the student about his or her progress.
- Find out what interests the student has. This might help you to find a way of making the student more comfortable in class. ➔



A periodical for teachers and tutors of adult ESL

P.O. Box 589
Dewitt, NY 13214
USA



Hands-on English

A periodical for teachers and tutors of adult English as a second language

Editorial

ESL is not 'remedial'

A well-meaning friend, inquiring recently about our profession, asked whether ESL was related to Special Education. We were taken aback, in part because we realized suddenly what a different view others have of our students.

Others seem to see our students as lacking something, as incapable, as disadvantaged. Once they learn English, presumably they will catch up, become 'normal.' Many educational institutions foster this attitude by making language requirements the prerequisite for any participation in their programs.

Overwhelmed

The students themselves foster this idea when they become overwhelmed by the language. It's easy for our students to fall into the role of the disabled. And if you've ever experienced a foreign culture in which you didn't speak the language, you can understand why. It doesn't take long before you feel incompetent.

We recently had this humbling experience, trying to type something in Vietnamese for a friend. Since we don't know any Vietnamese, the frustration level was high. We felt pretty stupid.

Imagine feeling stupid, 24 hours a day!

Broaden our horizons

There are things we as ESL instructors can do to help promote a healthier image of ESL, both among our students and in the public at large. Remind students how competent they are, and that they have something to offer. Emphasize classroom activities that draw on

the world of experience the students bring. Work from what they *can* do, not what they can't.

In the larger sphere, we can show an appreciation of the sophisticated nature of the process of learning a language. We can submit ourselves to the experience of learning a foreign language, and promote foreign language teaching in the schools.

We're the ones lacking something

People who don't yet speak English have a tremendous advantage over us. They have their native language—which comes with a history, a culture, thought processes, knowledge and concepts, most of which we will never have access to. Now, as they learn English and acquire a new culture, they have a chance to compare and contrast this with what they already know. They will therefore become larger than us. ←

Contents:

Grammar grab-bag:	
- "The Irregular Verbs Game".....	2
On the market:	
-Review of <i>Talk about Trivia</i>	4
Hints & tips:	
-Ideas for a busy season.....	5
From the field:	
- "The apartment building" puzzle.....	6
Tools & techniques:	
-Controlled composition.....	8
Dilemmas:	
-Multi-level classes.....	9
News & notes.....	10

Hands-on English

Volume I, Number 4
November/December 1991

Hands-on English (ISSN 1056-2680) is published six times a year (Jan./Feb., March/April, May/June, July/Aug., Sept./Oct., Nov./Dec) by Hands-on English, P.O. Box 589, Dewitt, NY 13214 USA.

Copyright © 1991 Hands-on English

Subscription rates:

U.S.: \$16.00 for regular subscribers, \$10.00 (discounted rate) for volunteers or teacher's aides, \$22.00 (multi-user rate) for libraries or institutions.

Canada and Mexico add \$4.00; countries outside North America add \$10.00 postage & handling. Single copies may be purchased at \$4.00 each.

Permission to photocopy: This periodical is copyrighted. However, we invite teachers and tutors who have a paid subscription (or whose institution has a paid subscription) to make as many copies as they need for their own classroom use.

Editor: Anna Silliman
(M.A., Teachers College, Columbia Univ.)
Contributing editor: Mary Jane Lucas

Address correspondence to the editor, *Hands-on English*, P.O. Box 589, Dewitt, NY 13214 USA.

Or, call the office at (315) 445-0785.

Subscribe today!

Send this form with your check or money order (U.S. funds only) to the above address.

Please subscribe me to *Hands-on English* for one year (six issues). I enclose:

- \$16.00 for a regular subscription
- \$10.00 for a volunteer or aide subscription
- \$22.00 for a library/institution

___ Postage & handling: Canada/Mexico add \$4.00
countries outside North America add \$10.00

Name: _____

Address: _____

Institution: _____

Position: _____

14

Grammar



"The Irregular Verbs Game"

Review of irregular verb forms is a necessary, but not always very interesting task. Here's a board game that can make verb practice a little bit more fun. And it gives students a chance to work together in a low-stress atmosphere.

Who can play

High beginners and intermediate students can benefit from the game. We also find that even advanced students need review of verb forms, so it's good for them, too. You can adjust the level of the game according to which verbs you choose.

Preparation

You'll need a stack of cards with a verb on each one. For lower-level students, choose only the irregular verbs they have already studied, and that they are familiar with. For more advanced students, you can select common irregular verbs from a list such as can be found in most ESL grammar books and dictionaries.

For one small group of students, you can simply write each verb on a card and you're ready to begin. If you have several groups of students, it makes more sense to photocopy a set for each group, and then cut them into cards. (There are some verb cards to start you out on page 4.)

How to play

Each student needs a different-colored marker, and each group needs one dice (or is it douse?). Students sit in groups of 3 or 4 and take turns rolling the dice, moving their markers, and following the directions on the game board.

Flexible rules

You and the students should decide on the rules you want to set. For example, what to do if a student doesn't know the answer—try again, or move back and wait for another turn.

When one student reaches the "finish" box, the game can end. Or, students can continue moving around the board if they wish—15 to 30 minutes is usually about right for this activity.

Why verb forms?

Although learning verb forms is not the same as learning to communicate, it does give many students a satisfying feeling of making progress because it is a concrete task to work on.

Start

F i n i s h

The Irregular Verbs Game

Take 1 card;
say the
verb forms

Take 1 card;
make a sentence
with the verb

Take 2 cards;
say the
verb forms

Take 1 card;
say the
verb forms

Take 2 cards;
say the
verb forms

Take 1 card;
make a sentence
with the verb

Take 1 card;
make a sentence
with the verb

Take 1 card;
say the
verb forms

Take 2 cards;
say the
verb forms

Take 1 card;
say the
verb forms

Take 1 card;
say the
verb forms

Irregular Verbs Game, continued from page 3.

Here are some verb cards to use with the game on the preceding page. Make a photocopy for each group of students, cut up the cards, and you're ready to play.

go	come	give	take
sit	stand	sleep	wake up
sing	speak	buy	sell
send	get	know	forget

On the market

Reviews of useful ESL materials

"Talk about Trivia: 1001 Questions" by Irene E. Schoenberg (1986 Longman Inc.) \$11.95. ISBN 0-582-90721-7

Here's a book of multiple-choice questions that's worth its weight in gold for adult ESL. Used for conversation starters or played as a game, students at all levels seem to find it fascinating.

The questions are carefully thought out, fun and interesting, and range over six different categories. The first part of the book is appropriate for beginning through advanced students; the second part is best for advanced students.

There's a lot of material here—if used as an occasional extra activity you might find *Trivia* part of your teaching repertoire all year.

To play it as a game, you can use the game board supplied in the back of the book, or you can design your own board. We made game cards by cutting the questions into strips, but this is time-consuming and not really necessary. Our students enjoyed discussing the answers together and only needed the teacher as a resource. There are also some nice suggestions for using this material at the beginning of the book.

One of the reasons the information in *Trivia* is valuable for ESL students is that it includes tidbits and details that don't come up in most ESL classes, but that can seem very important to newcomers trying to get a grasp on our culture.

--by Anna Silliman

Mail-order sources for ESL materials:
Alta Book Center or Delta Systems
Co.
1-800-ALTA/ESL 1-800-323-8270

Hints & tips

We've noticed students, teachers and tutors getting busier and busier this time of year, and more and more tired! To help you out we're including lots of hints and tips in this issue, for a hectic holiday season!

Low-tech "Storyboard"

You may be familiar with a computer program called "Storyboard," which presents the student with a paragraph written in blanks. The student guesses the missing words, gradually reconstructing the text.

You can have fun with this activity using only a chalkboard!

Choose a short text, or even a sentence, which the students have already studied. Write the text, in blanks, on the chalkboard. For example, if the text is "A man was walking down the street, thinking about his English class," the text on the board would look like this:

___ man ___ ___, ___

One word is given, to help the students guess what the text is about.

Let the students call out words they think belong in the text. If a word is guessed correctly, write it in the appropriate space. You'll be surprised how difficult this exercise can be, even with familiar text! It's a good way to provide some really intensive review.

Once they have the idea, you may want to have students lead the activity, or try it in small groups.

A word game

One of the best word games we know about could be called "Categories." Students are divided into teams of 3 or 4 and given a sheet with several categories listed, such as: Things in a Kitchen, Things in School, Parts of the Body, or any other topic they may be familiar with. The teacher calls out a letter, such as "S." The object is then for each team to think of a word (or words) in each category starting with "S." The game is more exciting if there is a time limit. You can continue playing as long as you like by calling out more letters.

Look for a very nice, ready-to-use presentation of this game in *Springboards* by Richard Yorkey (1984 Addison-Wesley Publishing Co.).

Erase-a-text

Here's a tip for helping your students to read and study a short, unfamiliar text intensively. First, write the text on the board (a sentence or two is enough) and discuss any new words. Ask one or two students to read the text aloud.

Next, carefully erase one word and ask a student to read the text again, supplying the missing word from memory. Erase another word, and call for a volunteer to read the text. As more and more words disappear, students will be challenged to recall them, and will focus intently. See if any student can read the text with only one word remaining!

Finally, follow up with a dictation of the text, to give the students a chance to put it all together again.

Treasure hunt

Here's a real change of pace for your students—make a "treasure hunt" of information for them to find.

First make a list of questions about the surroundings where your class is held. Include things they may not have noticed or that you would like them to know. Some examples: What's the name of the school librarian? What color is the telephone on the secretary's desk? How many classrooms are there on the third floor? What is in Room 116? (You might also consider writing your questions about the neighborhood around the school.)

Group the students into teams, giving each team a copy of the list and a time limit for finding the answers.

One benefit of this activity, besides fun, is to help the less outgoing students to feel more comfortable in their surroundings.

Narrate a video

If you have access to a VCR, show a silent movie and have your students narrate it while they are watching it. This can be good practice for any level of student, and a lot of fun, even for beginners. We had great success with Charlie Chaplin's *The Gold Rush*. Students began by merely describing the action, and gradually began discussing how's and why's as well. They also used their English to humorous effect, which all enjoyed. Best of all, since the focus was on the performers on screen, the students weren't self-conscious about speaking. ←

From the field: The apartment building

—Who lives where?

We are very pleased to present to you an activity by Jennifer Brown, teacher at the Westside Adult Learning Center in Rochester, N.Y.

This activity is not only fun, but can benefit your students by giving them a challenging problem to solve using their English skills.

On the next page there are 20 descriptions of tenants who share an apartment building. The object of the activity is to reconstruct the apartment building by deciding who lives in each unit.

Setting it up

I did this lesson with my intermediate-level students by having them work in small groups to match up each apartment with its tenant. I gave each group a large grid, with appropriate apartment numbers (1A – 5D) and a space for each apartment that was large enough to accommodate the descriptive strips. This gave the students a controlled area in which to work the solution.

As a follow-up activity, each group had to write a directory with the tenants listed in

alphabetical order, followed by their apartment number.

Whole-class activity

This lesson could also be done as a total group activity where students are each given one descriptive strip. They then must share information orally in order to arrange themselves within the building. Numbered sheets of paper (1A – 5D) could be taped to the classroom floor to designate each apartment number, and each student would have to find his or her proper location.

Customize for your class

If your class number does not equal 20, you would have to make some adjustments by either adding more tenants (roommates, husbands, wives or children of those described) or by giving some descriptions to the entire group before they start the activity.

Enjoy! ←

(Note: Jennifer patterned this lesson after an activity in Intermediate Communication Games, by Jill Hadfield.)

Answer key:

	A	B	C	D
5th floor—	Alan	Jim	Emma	Sarah
4th floor—	Linda	Scott	Agnes	Patricia
3rd floor—	David	Lucy	Maria	Carl
2nd floor—	Jill	Sue	Liz	Donna
1st floor—	Betty	Sandra	Timothy	Gary

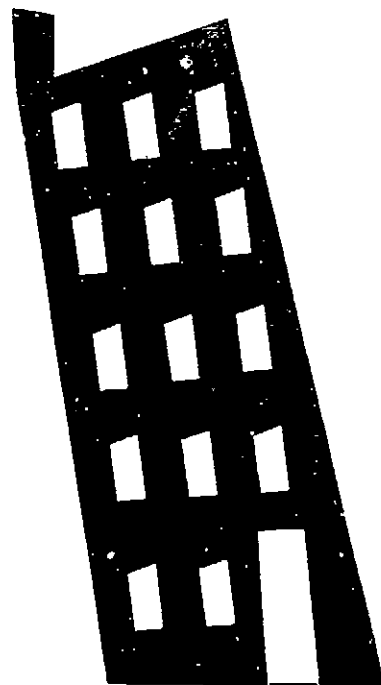

The tenants:

Find out who lives where!

<p>David Foye has many loud parties with his friends. The woman who lives next door to him has four cats.</p>	<p>Sandra Sullivan lives on the ground floor. One of her neighbors is a very handsome man and her other neighbor is a woman who always seems afraid when she sees Sandra's dog in the hallway.</p>	<p>Betty Lewis lives next to a woman who has a dog named Brutus. Brutus is huge and doesn't look very friendly! The woman who lives above Betty plays the violin.</p>	<p>Donna Roth lives in an end apartment. She babysits for her grandchildren until her daughter gets home from work at 4:45.</p>
<p>Patricia Drake lives above a man who is a French professor.</p>	<p>Jill Gressens lives on the second floor in an end apartment. She plays the violin in the City Philharmonic Orchestra.</p>	<p>Sue Kane lives below a woman who has four cats. One of her neighbors is named Jill.</p>	<p>Alan Green loves his expensive German sports car! He chose this apartment building because it has an excellent garage. His neighbor just moved in about a week ago.</p>
<p>Liz Jordan lives in the apartment above a man who was recently divorced. Her apartment door is marked "C."</p>	<p>Sarah Kingsford loves flowers and often goes to the garden to read and relax. It's very peaceful there. The woman who lives below her is named Patty.</p>	<p>Emma Jackson lives next to a woman who loves to sit in the garden behind the apartment building.</p>	<p>Linda Toomey has two pets in her apartment. She lives below a man who drives a Porsche.</p>
<p>Maria Rosa lives in the apartment between Carl's and Lucy's. She's very friendly and often invites her neighbors over for coffee and dessert. She lives below an elderly woman who was a professional singer.</p>	<p>Jim Pearce moved into this building five days ago. He loves his apartment because the view from the top floor is wonderful!</p>	<p>Gary Brenner lives next to a man whose first name is Tim. The woman who lives above him takes care of her three grandchildren every day after school.</p>	<p>Timothy Mathis just got divorced. He wants to date again but he's very shy. The woman who lives next door always smiles at him in the hallway. Maybe he'll ask her out to a movie.</p>
<p>Scott Sendall lives on the fourth floor between an elderly lady and a middle-aged woman who has a dog and a cat.</p>	<p>Carl Goodman lives on the third floor in an end apartment. He teaches French at the University.</p>	<p>Agnes Dimino is 76 years old. She was a famous singer in Chicago. She is retired, but still enjoys singing in her apartment in the afternoons. A nice young man who collects stamps lives next door to her.</p>	<p>Lucy Traynor has four cats!</p>

Tools & techniques:

"Controlled composition"--a writing exercise



The technique known as "controlled composition" is a useful way to help students focus on specific language structures. It is grammar practice, but in the context of a story. It is also an activity that is very useful for a multi-level group, since each student can work on a different exercise.

Procedure

Students read a short story. They then re-write the story, performing changes on the text as instructed. Lower-level students can start by copying the text, or by changing the subject (from "I" to "he," for example). Intermediate students can change the tense of the story, or combine sentences. More advanced students can write the text using reported speech, or use the text as a model for writing their own story.

To make sure everyone understands the exercise, have students write during class-

time. You can circulate to answer questions. Once students know what to do, this can be an excellent homework assignment.

Follow-up

This exercise would also make a good strip story, which you could use later for review. Use the five sentences resulting from exercise #4 below. Write them on strips of paper and scramble them. Ask the students to reassemble the story in the correct order.

Where to find more

We've provided one example for you to try. Here are two sources we recommend for more controlled composition:

10 Steps by Gay Brookes and Jean Withrow (2nd edition, 1988 Alemany Press).

Write Away, Books 1, 2 and 3, by Donald R.H. Byrd and Gloria Galligane (Newbury House Publishers). ←

An accident

1. I was driving my car to work.
2. I had a small accident.
3. I was waiting at a stop-light.
4. A man in a pick-up truck stopped behind me.
5. The light turned green.
6. The man in the pick-up truck honked his horn.
7. I started to drive across the intersection.
8. I saw a little girl crossing the street.
9. I stopped the car.
10. The pick-up truck hit my car from behind.

Instructions:

1. Copy the story, without the numbers.
2. Re-write the story so that it is about a woman named Mary. Start with:
Mary was driving her car to work.
3. Re-write the story so that it is about a man named Peter. Start with:
Peter was driving his car to work.
4. Re-write the story, combining the sentences like this:
Combine 1 & 2, using the word *while*. (Example: *While I was driving to work, I had. . .*)
Combine 3 & 4, using the word *while*.
Combine 5 & 6, using the phrase *as soon as*.
Combine 7 & 8, using the word *when*.
Combine 9 & 10, using the word *when*.
5. Write the story as a conversation between two friends. Example:
"Yesterday I had a small car accident." "Really? What happened?"
6. Write the story using reported speech. Example:
My friend had an accident yesterday. He told me that while he was driving to work. . .
7. Write a story about an accident you saw.

Dilemmas

We welcome your questions about ESL teaching dilemmas. Maybe we have an idea that can help. If not, we'll look for someone who does!

Dear *Hands-on English*,

Can you recommend a few good books to use with multi-level classes?

P.B., Mechanicsburg, PA

This is just about the toughest dilemma there is in language teaching, and unfortunately one that many adult ESL teachers face. We consulted a number of experienced teachers for some ideas on this problem.

One book that several teachers recommended is *Double Action English* by Earl Stevick and Jane Yedlin (1985, Addison-Wesley Publishing Co.) Students find the *Double Action* pictures interesting and funny, and there's lots of vocabulary presented. Each of the 10 lessons in the book has exercises at three levels. There are also the *Double Action Picture Cards* that you can use in conjunction with the book.

This is one of the few works really designed with multi-level activities. However, it is intended as a supplement, not as a main text.

We know of no "main text" that is effective with a multi-level group. However, there is a new book coming out from Oxford University Press called *Crossroads*, that looks promising for multi-level activities and exercises. Book 1 has just been published; look for Book 2 in the spring. (*Hands-on English* will review the book as soon as it comes out.)

A challenge

All of our sources agree that a multi-level class takes a lot of planning and a lot of extra preparation from the teacher.

One teacher strongly recommends using stories. She starts the lesson with the whole group, reading and discussing a story at a level all the students can understand. Later she divides the class into groups and has them work on exercises about the story that she has prepared for their level. This teacher also emphasized that lower-level students can sometimes benefit just from listening.

There are other supplemental activities that can work well with multi-level groups. *What's*

the Story?, a set of large photos from Longman, Inc., is a very flexible teaching tool that works well with almost any group. The student books have exercises ranging in level from high beginner to quite advanced, and might be worth investing in if your program has mixed-level classes on an ongoing basis.

Many teachers like the flexibility of "rods" as a language teaching tool—these small colored blocks are known as Cuisenaire rods and were originally developed to teach math concepts. For lots of ideas on how to use the rods to teach structures, see *Communication Starters* by Judy Winn-Bell Olsen (1977 Alemany Press), pp. 27-35. Used carefully, rods are an open-ended tool that can provide students at varying levels an opportunity to learn and practice. You can order a set of rods from the Cuisenaire Company, 1-800-237-3142 (item #010-290, \$8.95).

'Controlled composition' is a writing activity that can work well for a mixed-level class. Students read a short text, then re-write it making specified structural changes. Using the same original text, you can assign different students to do different exercises, depending on their needs. See page 8 of this issue for an example of controlled composition.

Finally, *Hands-on English* tries very hard to include activities in each issue that will work in a multi-level class. We hope you will find some of these helpful.

An editorial comment

We feel that, in the short term, there are some benefits to a multi-level group. There are some activities that are a lot of fun in this environment, and students can learn to help each other very effectively.

In the long term, though, we think students in this situation are being short-changed. Sensible instruction in the intricacies of a language requires careful, orderly presentation and great sensitivity to the stages of learning in the student—impossible in a class of 25 students at all different levels.

(Would you want to learn a language this way? We wouldn't.)

We certainly welcome any thoughts and suggestions our readers might have on the subject of multi-level classes. ←



News & notes



Upcoming conferences

♦ **March 3-7, 1992**—Teachers of English to Speakers of Other Languages (TESOL) in Vancouver, British Columbia, Canada. For information call TESOL at 703-836-0774. If you go, stop by the *Hands-on English* booth and say hello.

♦ **April 2-5, 1992**—California TESOL, Sacramento, California, USA.

♦ **May 9-13, 1992**—Society for Intercultural Education, Training and Research (SIETAR) in Montego Bay, Jamaica. The theme of the conference is "Strategies for Cross-Cultural Communications in the New Information Age." Featured speaker Paolo Freire. For information write: SIETAR/SASC, 8000 Westpark Dr., Suite 130, McLean, VA 22102 USA. Phone: 703-790-1745.

Another journal

The international TESOL organization has launched a new publication, called TESOL Journal. It's a "magazine for TESOL professionals focusing on the latest ideas and techniques that promote successful ESL/EFL classroom instruction." We think this is a step in the right direction. Call 703-836-0774—if you haven't seen the journal yet, maybe they'll send you a freebie.

Amnesty, Citizenship and Government

Do you teach any of these subjects? Don't miss the reviews of eleven works on teaching these topics to ESL students which appear in the latest issue of the *TESOL Quarterly* (Volume 25, Number 1).

Western Europe

Things are changing all over Western Europe, and reportedly anti-immigration sentiment is growing. Immigration is a political issue in many states there.

Issues there include fears of a massive influx of refugees from the east, economic tension, unemployment, racial tension, religious tension, and urban crowding. News reports seldom mention language problems, but we're sure that's an issue as well (linguistic tension?).

We wonder what effect, if any, an eventual European unification will have on immigrants and refugees there.

Speaking of Refugees

We've received notice about a monthly journal called *Refugee Reports*, covering refugee issues both domestic and international. Topics include legislation and regulations affecting refugees, local and national programs, international situations, meetings and statistics.

Subscriptions are \$35. from U.S. Committee for Refugees, 1025 Vermont Ave., N.W., Suite 920, Washington, D.C. 20005.

Notice anything different?

Your mailing label now carries a date in the upper right-hand corner. (Go ahead and look.) This is the date we entered your subscription for *Hands-on English*. Now you'll know when it's time to renew next year!

Who are you?

Hands-on English subscribers are working with ESL students in many different kinds of programs. These include:

- Refugee programs
- Adult education programs
- Literacy programs
- Volunteer tutoring
- Community colleges
- Intensive ESL programs
- Secondary schools
- Workplace programs
- Correctional facilities
- Libraries
- Resource centers

... across the U.S. and in Canada, with a growing number overseas.

Recruiting

If you know anyone who wants a free sample of *Hands-on English*, let us know and we'll send them one right away!

Happy Holidays to all!

... from the staff at *Hands-on English*. ←

Announcing. . .

English Mini-grants

Hands-on English is pleased to announce that it will award a limited number of small grants (\$50-\$100 each) to teachers and tutors of ESL for an instructional project.

We at *Hands-on English* intend that these grants will encourage the development of practical teaching techniques for ESL. We see these Mini-grants as an integral part of our mission to encourage and assist teachers and tutors in a practical way.

The grants will be open to any teacher or tutor of ESL. Further details as to the number of grants available and the application process will appear in the January issue of *Hands-on English*.

Application forms will be available starting in January, and applications will be accepted through April 30, 1992. For more information on how to apply, write to:

Hands-on English
attn: Grants Manager
P.O. Box 589
Dewitt, NY 13214
USA

Advertising

Let them know you saw it in Hands-on English! Thanks.--the Editor



American English Publications
10 Years of E.S.L. Service

10th Anniversary *SPECIAL*

50 pictured-verb flashcards (4 1/4 by 5 1/2 inches)

FREE

Send \$1.00 for Shipping and Handling to:

American English Publications

356 Dongan Hills Avenue - New York, New York 10305
Tel. (718) 667-6637

How about sharing your favorite hints & tips with other readers?

If you've found something that works for you, chances are somebody else might find it useful, too!

Jot down your hint on this card and send it to *Hands-on English*, P.O. Box 589, Dewitt, NY 13224 USA. We'll try to include some of these reader suggestions in each issue.

"Hints & tips"

from: _____

Materials needed (if any):

Amount of time needed:

Appropriate for student level(s):

Description of activity:



A periodical for teachers and tutors of adult ESL

P.O. Box 589
Dewitt, NY 13214
USA



Hands-on English

A periodical for teachers and tutors of adult English as a second language

Group work: Famous Americans

An information-gapping activity

It's history season again—since Martin Luther King, George Washington and Abraham Lincoln's birthdays all fall during January and February, we thought it would be appropriate to offer you a "Famous Americans" activity to do with your students.

This is an information-gapping exercise. That is, the students need to find information to fill in the 'gaps' on a worksheet. To get this information they have to ask each other, because each student has one piece of the information.

This leads to lots of milling around, talking and asking, which is good practice in a non-threatening atmosphere, and can be lots of fun.

Learning the roles

First, you need to give each student a role card (see page 2). If your group has more than 10 students, make two copies of the cards and form two groups.

Explain that they will later pretend to be the person on the card, so they will need to study the card carefully. You should give them time to practice, or even give out the cards a day or two ahead of time. In any case, the students should be able to explain who they are *without* looking at the card.

Fill in the blanks

Next, hand out the blank worksheet (see page 3). Tell the students they must interview each other to discover which student is playing each role by asking "What's your name?" If a student says 'Abraham Lincoln,' for example, they write that student's name in the blank.

They can then ask the famous American to "Tell me something about yourself," and take some notes if they wish.

Allow plenty of time for the students to finish this exercise. Then go over the answers together as a group and discuss each famous person.

Why it works

Each student only has to learn one bit of information, and gets to repeat it over and over. This is in itself confidence-building, and the teacher can select easier roles for lower-level students, if necessary to help them succeed.

There is also a surprisingly powerful boost to the self-esteem that comes from playing an important role, even for a few minutes. Students will often speak more firmly and confidently when playing a strong role. The famous persons on this list were carefully chosen for their dignified, even revered status, to help generate this effect.

Don't be afraid to ham it up a little. We went so far as to tell our 'George Washington' how very honored we were to have him visit our classroom. Instead of laughing, he nodded seriously and said "No problem. I am happy to be here." He looked very presidential. ←

☺ ☺ ☺ ☺ ☺	
Group work:	
-Famous Americans activity	1
Multi-level crossword:	
-Looking for a job.....	4
Idea file:	
- "What happens next?"	7
Grammar grab-bag:	
-Describing things with adjectives	8
Editorial:	
-Oops! Wrong gesture.....	9
News & notes	10
About the Mini-grants	12

Hands-on English

Volume I, Number 5
January/February 1991

Hands-on English (ISSN 1056-2680) is published six times a year (Jan./Feb., March/April, May/June, July/Aug., Sept./Oct., Nov./Dec) by Hands-on English. P.O. Box 589, Dewitt, NY 13214 USA.

Copyright © 1991 Hands-on English

Subscription rates:

U.S.: \$16.00 for regular subscribers, \$10.00 (discounted rate) for volunteers or teacher's aides, \$22.00 (multi-user rate) for libraries or institutions.

Canada and Mexico add \$4.00; countries outside North America add \$10.00 postage & handling. Single copies may be purchased at \$4.00 each.

Permission to photocopy: This periodical is copyrighted. However, we invite teachers and tutors who have a paid subscription (or whose institution has a paid subscription) to make as many copies as they need for their own classroom use.

Editor: Anna Silliman

(M.A. Teachers College, Columbia Univ.)

Contributing editor: Mary Jane Lucas

Address correspondence to the editor, *Hands-on English*, P.O. Box 589, Dewitt, NY 13214 USA.

Or, call the office at (315) 445-0785.

Subscribe today!

Send this form with your check or money order (U.S. funds only) to the above address.

Please subscribe me to *Hands-on English* for one year (six issues). I enclose:

\$16.00 for a regular subscription

\$10.00 for a volunteer or aide subscription

\$22.00 for a library/institution

___ Postage & handling: Canada/Mexico add \$4.00
countries outside North America add \$10.00

Name: _____

Address: _____

Institution: _____

Position: _____

15

Famous Americans . . . continued.

Here are 10 role cards to hand out to your students. Ask them to study the card and to remember the information on it—once the activity starts they can't look at the card.

My name is Abraham Lincoln. I was President of the U.S. from 1861 to 1865. I fought the Civil War and freed the slaves.

My name is George Washington. I was a general in the Revolutionary War. In 1789 I became the first President of the U.S.

My name is Clara Barton. I was a nurse in the American Civil War. Later I organized the American Red Cross.

My name is Charles Lindbergh. I was a flyer. In 1927 I was the first person to cross the Atlantic in an airplane.

My name is Susan B. Anthony. I lived from 1820 to 1906. I was a leader in the women's movement in the U.S.

My name is Martin Luther King. I was a leader of black Americans in the 1950's and 60's. I worked for civil rights.

My name is Franklin D. Roosevelt. I was President of the U.S. during World War II. I was elected president four times.

My name is Thomas Edison. I invented the electric lightbulb and the phonograph. I lived from 1847 to 1931.

My name is Henry Ford. I was a businessman. I lived from 1863 to 1947. I built cars and started the first automobile factory.

My name is Sandra Day O'Connor. I am a judge on the Supreme Court, the highest court in the U.S. I became a Supreme Court judge in 1981.

Famous Americans

Instructions: Talk to the other students. Ask them "What's your name?" and "Tell me about yourself." When you learn something about a famous American, write it on your paper.

Who is who?

Why is this person famous?

1. _____ is Abraham Lincoln.
2. _____ is George Washington.
3. _____ is Clara Barton.
4. _____ is Charles Lindbergh.
5. _____ is Susan B. Anthony.
6. _____ is Martin Luther King.
7. _____ is Franklin D. Roosevelt.
8. _____ is Thomas Edison.
9. _____ is Henry Ford.
10. _____ is Sandra Day O'Connor.

Multi-level crossword puzzle

Here's a unique crossword puzzle—you can use it with different levels of students, or with a multi-level group.

The puzzle comes with three sets of clues. Level A is intended for beginning-level students—the clues are in a dialog to make them easier to understand. If this is still too challenging for your beginning students, you could present it orally first (with the answers), then hand out the written text. Or, you could supply the students with a word-list to choose from (see page 6).

Level B is intended for intermediate-level students. The clues are written in the form of definitions.

Level C could be used for more advanced students, who are ready to handle natural, "unsheltered" English.

We have arranged the puzzle and clues in vertical strips. Cut out the clues you wish to use, paste them together with the puzzle and photocopy the page for your students.

The great bonus of this activity is that once all the students have completed the puzzle, the whole group can discuss the answers together. The levels are different, but the answers are the same. ←

Looking for a job

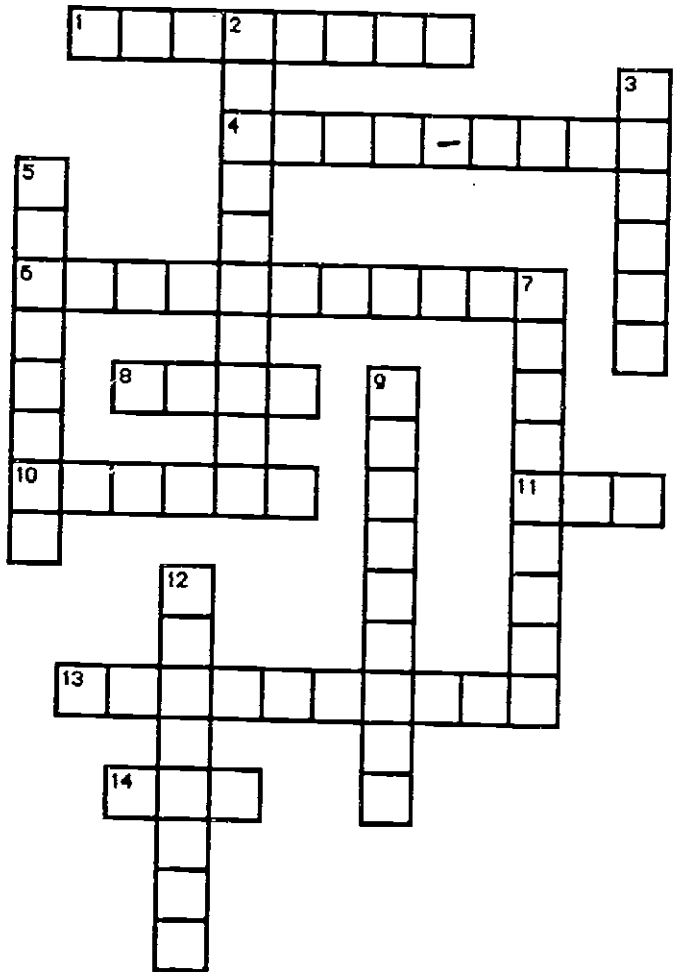

Answers:

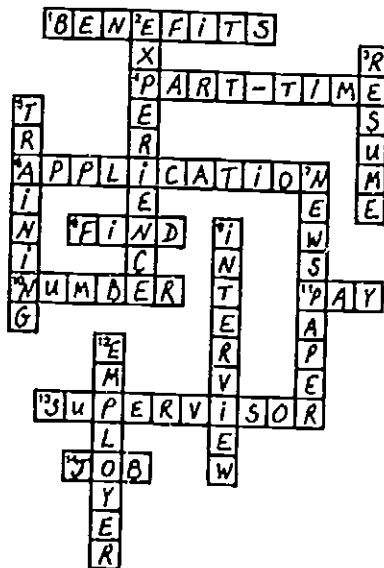

Level A clues

Looking for a job

Two students are talking:

Carlos: Hi! How are you?

Anh: OK. I'm not working right now. I don't have a (14 Across) yet. How about you?

Carlos: I don't have a full-time job. I work only 10 hours a week. It's a (4 Across) job.

Anh: I'm looking for a job. I hope I can (8 Across) a job before next month.

Carlos: Why don't you buy a (7 Down)? You can read about job openings there.

Anh: I already have an appointment at XYZ Company tomorrow. My (9 Down) is at 10:00 am.

Carlos: Great! Good luck.

Anh: Thanks.

The next day:

Mr. Carlson: Hello, my name is Fred Carlson.

Anh: Nice to meet you.

Mr. C: Please fill out this (6 Across) form, and write your Social Security (10 Across) here.

Anh: OK.

Mr. C: Who do you work for now? Who is your (12 Down) ?

Anh: I'm not working right now.

Mr. C: Oh, I see. Did you have a job in your country? Tell me about your work (2 Down) .

Anh: I used to work in a hospital. Here is a copy of my (3 Down) . It tells all about my education and work experience.

Mr. C: Hm. Very interesting. When can you start working for us?

Anh: I can start now.

Mr. C: Very good. For the first 3 months, you will be learning about the job. This is your (5 Down) period. Mr. Smith will be your (13 Across) . He will show you what to do. Do you have any questions?

Anh: Yes, how much does this job (11 Across) ?

Mr. C: The pay for this job is \$6.50 an hour.

Anh: Does this company have health insurance for workers? I would like to know about the (1 Across) at this company.

Mr. C: Just a moment. I'll give you some information about our benefits.

Anh: Thanks.

Level B clues

Looking for a job

Across clues:

1. Health insurance, vacation pay and sick leave are called job _____.
4. If you work fewer than 40 hours per week, you are a _____ worker.
6. You usually fill out an _____ form when you apply for a job.
8. Sometimes it takes a long time to _____ a job.
10. Give your employer your Social Security _____.
11. I like my job, but the _____ is too low.
13. If you have a question about your job, talk to your _____.
14. I'm looking for a _____ in the evenings.

Down clues:

2. The work you did in the past is your work _____.
3. Write about your education and work experience on a piece of paper. This is your _____.
5. I'm going to take a _____ course for three months to learn this job.
7. If you are looking for a job, you can go to an employment agency, or you can read the _____.
9. Someone from the company will meet you and ask you some questions. This is a job _____.
12. The person or company you work for is your _____.

Level C clues

Looking for a job

Across clues:

1. This job offers excellent _____ and a good salary.
4. _____ workers do not receive benefits, but they can apply for health insurance if they work more than 20 hours per week.
6. Send your _____ with a letter and a copy of your resume to the Director of Personnel, XYZ Company.
8. The Employment Agency can help you _____ a job that you qualify for.
10. You must have a Social Security _____ before you can get a job.
11. At this company, you can earn overtime _____ if you work more than 40 hours per week.
13. When you have three years' experience at this company, you can apply for the position of _____.
14. This company has two _____ openings for workers with computer skills.

Down clues:

2. An ad in the paper: "Waiters and waitresses needed. Will train. No _____ necessary."
3. If you are applying for jobs, you should prepare a _____ to give employers so they know something about your background.
5. I'd like to enroll in a _____ program for auto repair.
7. Look in the classified section of the _____ for job listings.
9. Dear Mr. Antonov, We have received your job application. Please call our office and we will set up an appointment for an _____.
12. You can give the name of your former _____ as a reference.

Word list

application
benefits
employer
experience
find
interview
job
newspaper
number
part-time
pay
resume
supervisor
training



Idea file is a regular feature of *Hands-on English* that brings you teaching ideas you can save for emergencies, or just for when you need a quick lesson. Clip this card, and keep it in a notebook or file with other good ideas, and you'll be ready for action!

"What happens next?"

This activity comes to us from Karen Campbell, who teaches in an Amerasian program, Syracuse City Schools, NY.

A directed reading-thinking activity

This activity was passed along to me by a reading specialist. It is well known among reading teachers, but not used as often by ESL teachers.

I've found it to be excellent for oral language development, as well as reading at the intermediate level.

How to do it

You will need a good story for this activity. The best kind of story would be one with a surprise ending, or in which there is some suspense. Divide the story into several sections, just before turning points in the story, if possible.

Students will see the story section by section, and make predictions about what will happen. An overhead projector is *very* useful for this, but I have done the activity without one. (You can give out copies of the story with lines drawn to separate the sections of the text, and 4"x6" index cards for students to cover up the text they shouldn't look at.)

Why it works

This is a group activity, with the teacher as facilitator. Students get a chance to give their own predictions and interpretations of what will take place in the story. They also have to give reasons for their statements, which gets them closely involved with the text. ↵

"What happens next?"

Purpose: Directed reading, speaking, thinking.
Level: Adaptable for many levels; best for low intermediate and up.
Time: Up to an hour, depending on the story.
Materials: A good story, overhead projector (if available).

Pre-reading:

1. Have the students generate some ideas about a theme related to the story. You can use pictures for this if you like.
2. Write down the ideas as students generate them, on a blackboard or overhead.
3. Make a 'semantic map' of these words, putting the ideas in a hierarchy.*

Predicting from the text:

4. Start with the title alone. Ask students "What do you think the story is about?" This is a brainstorming session, but urge students to make *specific* statements. Encourage everyone to participate. There is no right or wrong!
5. Write down students' predictions as they make them.
6. Read the story section by section with the whole group, generating predictions before each one.
7. As you go, compare the predictions to preceding sections. Ask whether the students want to keep the prediction, or throw it out.
8. As predictions are confirmed, say "Prove it. Find the part in the story that tells."

*For an article on the mapping technique, see *Hands-on English*, Vol.I, No.1, page 5.

Grammar grab-bag: Describing things—an adjectives worksheet

Have your students do the worksheet below. Be sure to discuss the categories with them first, giving examples, so everyone is clear about what they mean. Students may use dictionaries for this activity, if they wish.

When the students are finished, go over the answers as a group. Have students give examples with each adjective—for example, a tall person, tall building, etc.

Follow-up

For each category, ask students to list other adjectives they know, and write them on the board. If you have six groups of students, each group could work on one category. Or, all the students can work together.

Speaking and writing

Have the students sit in pairs and describe something orally to each other. This could be something in the room, or some pictures of objects that you have provided.

Then, ask each student to describe something in writing. Again, they could describe objects in the room, a picture, or perhaps something in their memory. The writing could be done in class, or as a homework assignment.

Adapting this lesson

The adjectives on the list below might be most appropriate for an intermediate group. You can easily adapt the list, though, to suit your own students. Substitute your own list of words for the one below.

For beginners, be sure to use plenty of words they already know. They shouldn't have to absorb too much new vocabulary at once. For example, for 'Size' try big, medium, small, etc.

If you have only a few advanced students in the group, one way to deal with this is to have an extra list of adjectives ready, that you have prepared ahead of time. Those students who finish the worksheet quickly can work on the second list until the other students are ready.

Why it works

Putting things in categories seems to be a good way to help understand and remember things. You might suggest to your students they keep this sheet in their notebooks, and add new words to it over time. ←

bitter	freezing	rough	spicy	tiny
bright	huge	round	sweet	warm
chilly	pale	slippery	tall	
dark	rectangular	smooth	thin	

Put each of these adjectives in the correct category:

Size

.....
.....
.....

Shape

.....
.....
.....

Color

.....
.....
.....

Temperature

.....
.....
.....

Texture

.....
.....
.....

Taste

.....
.....
.....

Oops—wrong gesture.

Cultural difference

On his trip to Australia a few weeks ago, President Bush flashed the “V” for victory sign—a standard, presidential thing to do. We were very surprised when we heard it reported in the news that in Australia this is considered an obscene gesture.

Much was made in the media at the time about this awful mistake.

What about Churchill?

Unfortunately, *Hands-on English* was not able to fund a research trip to the Australian continent, so we were unable to discover more details first hand. We did wonder, however, how Australians felt about Winston Churchill’s flashing obscene gestures at their troops in World War II.

Another goof

In reading about Bush’s embarrassment in Australia, we were very much reminded of President Kennedy’s famous visit to Berlin in 1962 during the Cold War. In a speech to the people of Berlin, televised world-wide, Kennedy said “Ich bin ein Berliner!” a remark that supposedly translates literally to mean ‘I am a jelly donut.’ *

The people of Berlin cheered wildly, not, of course, because they were glad to hear the U.S. president was a pastry. There was no misunderstanding here. Kennedy’s intended meaning was perfectly clear—the United States would not allow Berlin to die, or be swallowed up by the Communist bloc. It was an emotional moment in Berlin history not marred in the least by the small grammatical error.

Not such a big deal?

We’re guessing that the people of Australia didn’t misunderstand Bush’s gesture, either. Of course they knew he was on a good-will tour. His intended meaning must have been clear.

ESL issues

We believe that most people, when listening to foreigners, listen for the intended meanings. Nonetheless, ESL students are anxious to be correct, both in their speech and body language, and do not want to inadvertently cause offense, or be ridiculed. Gestures,

therefore, can be an important topic for your students.

Teaching suggestions

There are some several good sources of pictures to help explain American body language. We think the best is in Pro Lingua Associates’ *The ESL Miscellany* (Second edition, 1991), which groups the gestures and facial expressions according to the function being communicated—approval, greeting, nervousness, etc. (Included also is an illustration of a gesture you may not feel comfortable demonstrating yourself, but which the students need to know.)



For intermediate students, there is a nice chapter on gestures in *Face to Face; the Cross-Cultural Workbook* by Virginia Zanger (Newbury House, 1985). This includes a case study, or anecdote about a misunderstanding, pictures, and an interview for your students to conduct with an American.

For advanced students there is a chapter on ‘Non-verbal communication’ in *Beyond Language* by Levine and Adelman (Prentice-Hall, 1982). This includes a rather lengthy discussion, some nice clear pictures and some exercises.

If you don’t have any of these materials, perhaps the most sensible way to study non-verbal language with your students is to ask them to report about gestures they have observed Americans using. Then you and the students can discuss the context and meaning, and perhaps make some cross-cultural comparisons. ←

* What Kennedy should have said was: “Ich bin auch Berliner,” or simply “Ich bin Berliner.”



Upcoming conferences

♦ **March 3-7, 1992**—Teachers of English to Speakers of Other Languages (TESOL) in Vancouver, British Columbia, Canada. For information call TESOL at 703-836-0774. Stop by the *Hands-on English* booth and say hello!

♦ **April 12-14, 1992**—National Center for Family Literacy (NCFL). Conference at U. of North Carolina, Chapel Hill. Contact: NCFL, 401 S. 4th Ave. #610, Louisville, KY 40202-3449. Tel: 502-584-1133.

♦ **May 3-7, 1992**—International Reading Association (IRA). "Literacy: The Language of Freedom," Orlando, FL. Contact: Conferences Div., PO 8139, Newark, DE 19714-8139. Tel: (302) 731-1600.

United Nations

Boutros Boutros Ghali of Egypt has formally taken office as Secretary-General of the UN. He is only the sixth person to hold that office.

Graffiti

A Vietnamese reader of the *National Geographic* noticed some graffiti in Vietnamese in a photograph of an East German factory (Sept. 91, p.27). He wrote in to explain that *Con tao làm việc ở đây* means "I worked here," a message apparently left by a guest-worker.

Asian kids in school

Researchers from the University of Michigan investigated why Asian children excel in American schools. What they found is that family values, more than anything else, contributed toward success in school. For a very interesting article about their study, see *Scientific American*, February 1992, pp. 36-42.

You're part of a trend

It is estimated that by the year 2000 (which isn't too far away!) there will be 17.4 million adults in the U.S. whose English is limited. They will make up 29% of the new entrants to the labor force.

Gourmet sentiments

Here's a wonderful quote from Jeff Smith, from his TV show "The Frugal Gourmet" on PBS: "A hundred years from now the Spanish-speaking people will be a huge part of our culture. But I'm not threatened by that! Not at all—any people who can cook like this have got to have a profound history, and a good heart."

Quiz

There are now a total of 1,172,000 students enrolled in ESL Adult Education Programs (through the Dept. of Education). You can probably guess which five states have the highest enrollments. But can you rank them in order? (See answer below.)

For more information like this, and a very interesting overview of ESL in Adult Education, send for *Teaching Adults with Limited English Skills: Progress and Challenges*, an 80-page report put out by the U.S. Department of Education. Write to:

Joyce Campbell
U.S. Dept. of Education
Div. of Adult Ed. and Literacy
400 Maryland Avenue, SW
Rm. 4428, MES Bldg.
Washington, DC 20202

The publication is available free of charge.

NMPCTLFWSQPCDHGESL

We get awfully sick of all the acronyms in the education biz. Just FYI:

ERIC is the Education Resources Information Center, which has a database of educational documents, available in many libraries.

NCLE is the National Clearinghouse on Literacy Education, a branch of ERIC, which has many resources on ESL. (See address below.)

Workplace literacy

Two new documents on workplace literacy are available free of charge. They are *Workplace Literacy Programs for Nonnative English Speakers*, and *A Learner-Centered Worker Education Program* (about a program in Vancouver, BC). Write to:

NCLE
Center for Applied Linguistics
1118 22nd Street, N.W.
Washington, DC 20037

Include a self-addressed, stamped envelope.

Your mailing label

The date that now appears in the upper right-hand corner of your mailing label is the expiration date of your subscription to *Hands-on English*. ↩

Answer to quiz:

From the highest number of enrollments, they are CA, FL, TX, NY, IL.

Advertising

Let them know you saw it in *Hands-on English!* Thanks--the editor.

Need an idea for your teaching?
Trying to solve a teaching dilemma?
Have a question, but don't know who to ask?

Call the *Hands-on English*

Hotline



(315) 445-0785

Best time to call: 6-8 pm EST, Sun-Fri.
Or, leave a message on our machine.

Maybe we have an idea that can help.

Linmore Publishing

FIRST WORDS



Linda Mrowicki

A teachers' press

Call or write for our catalog:

Linmore Publishing
Box 1545
Palatine, IL 60078
(800) 336-3656



American English Publications

10 Years of E.S.L. Service

356 Dongan Hills Avenue - New York, New York 10305
Tel. (718) 667-6637



A SPECIAL PRICE FOR A SPECIAL BOOK

MAKING IT.. A survival skills workbook that's perfect for adult immigrant students



Teacher's EdIt. (44 pp.)	\$5.95 \$4.95	Chart Book (14 charts)	\$4.95 \$3.95
Student's Book (108 pp.)	\$8.95 \$7.95	Flashcards (124 cards)	\$5.45 \$4.45
COMPLETE SET \$24.95 \$19.95			

About the Mini-grants

In our last issue we announced the first annual *Hands-on English* Mini-grants, to be awarded to teachers and tutors of ESL for an instructional project.

Here we include answers to some of the questions you may have about the Mini-grants.

Q: What kinds of projects are appropriate for these grants?

A: Any instructional project that you will actually use with your student(s) will be considered. The nature of your project depends on the needs of your student(s), and might include any of a wide variety of possibilities.

Q: What is *Hands-on English* looking for?

A: We are interested in funding a project that will benefit your student(s) in a practical way. Furthermore, we are looking for projects that could be adapted and used by other teachers or tutors. (We will report on each project in the periodical, so that other instructors can benefit from your ideas.)

Q: What will the grant pay for?

A: Materials, books, equipment or fees that you specified as necessary for your project.

Q: How many grants are available?

A: This year we will award a minimum of five grants of up to \$100.US each.

Q: What is the deadline for applying?

A: April 30, 1992.

Q: Who will review the applications and how will they decide who gets one?

A: A committee of people from ESL teaching, ESL tutoring and ESL literacy will read the applications and rank them according to: the anticipated benefit to your students, the practical nature of the idea, and the clarity of your objectives. ←

For more information, and an application form, write to: Hands-on English, Grants Manager, P.O. Box 589, Dewitt, NY 13214 USA.



A periodical for teachers and tutors of adult ESL

P.O. Box 589
Dewitt, NY 13214
USA

BULK RATE U.S. POSTAGE PAID SYRACUSE, NY PERMIT NO.764
--



Hands-on English

A periodical for teachers and tutors of adult English as a second language

Multi-level crossword puzzle:

Citizenship puzzle

In this issue we offer another multi-level crossword puzzle. The topic is citizenship—especially relevant in Canada right now, as National Citizenship Week is April 12-18. In the U.S. the upcoming elections make government and related topics timely for our students.

This puzzle can be used in three different ways, for three different levels of students, which we call A, B and C.

Level A

For Level A students (high beginners) you should provide as much support as possible. You may want to divide this activity into two: *first*, give each student a copy of the clues, and present some choices for each answer on the blackboard or overhead. Rather than coming up with the answer themselves, they can select from the list.

Choose the best answer:

Across	Down
1. questions/information	2. immigrant/native
6. months/years	3. policeman/doctor/judge
7. government/family	4. language/word
9. communist/ democratic	5. state/federal/provincial
11. sing/vote/work	8. test/sleep/answer
12. live/visit	10. tourist/citizen
14. meeting/election	13. rights/crimes

The students could work on this together in small groups, or as a whole-class activity, discussing the answers with the teacher. *Then*, have them work on the puzzle.

Level B

With Level B students (intermediate) you can hand out the puzzle on page 9 as is. If the students have trouble finding an answer, they can check the word list at the bottom of the page.

Level C

For Level C students (high intermediate - advanced), have them work on the puzzle *without* the word list. (You'll have to cover up the bottom of the page before you photocopy it.)

A delicate balance

The goal for this, as in other language learning activities, is to keep it challenging enough to be interesting, but never frustrating. If you see a student becoming frustrated with the puzzle, offer another level of support. ←

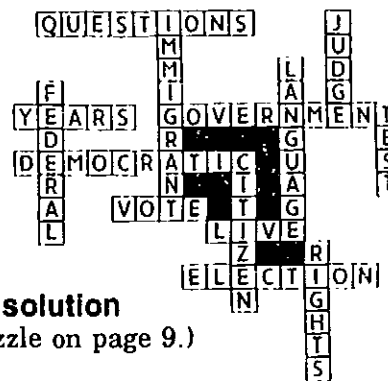

Puzzle solution

(See puzzle on page 9.)

Contents:

Grammar grab-bag:	
- Present perfect activity.....	2
Idea file:	
- Student-generated photo stories.....	4
Group work:	
- Conversation wheel.....	6
Hints & tips:	8
Editorial:	
- The 'official English' controversy.....	10
News & notes	11
On the market:	
- Review of <i>What's the Story?</i>	12

Hands-on English (ISSN 1056-2680) is published six times a year (Jan./Feb., March/April, May/June, July/Aug., Sept./Oct., Nov./Dec) by Hands-on English, P.O. Box 589, Dewitt, NY 13214 USA.

Copyright © 1992 Hands-on English

Subscription rates:

U.S.: \$16. for regular subscribers, \$10. (discounted rate) for volunteers or teacher's aides, \$22. (multi-user rate) for libraries or institutions. Single copies are \$4. each. Canada and Mexico add \$4.; countries outside North America add \$10. for postage & handling.

Permission to photocopy: This periodical is copyrighted. However, we invite teachers and tutors who have a paid subscription (or whose institution has a paid subscription) to make as many copies as they need for their own classroom use.

Please don't make copies for colleagues! We survive on the subscriptions of our readers.

Editor: Anna Silliman
(M.A., Teachers College, Columbia Univ.)

Address correspondence to the editor, *Hands-on English*, P.O. Box 589, Dewitt, NY 13214 USA. Or, call the office at (315) 445-0785.

Subscribe today!

Send this form with your check or money order (U.S. funds only) to the above address. Renewing? Use this form and mark it "R."

Please subscribe me to *Hands-on English* for one year (six issues). I enclose:

\$16.00 for a regular subscription
 \$10.00 for a volunteer or aide subscription
 \$22.00 for a library/institution

____ Postage & handling: Canada/Mexico add \$4.
countries outside North America add \$10.

Name: _____

Address: _____

Institution: _____

Position: _____

16

Grammar



"Have you ever eaten pizza?"

Present perfect exercise

Struggle with the p.p.

For some reason, the present perfect always seems to be a problem in ESL, especially for beginners and intermediates. Perhaps that's because our traditional "time line" explanation of the present perfect is very hard for students to grasp.

Let's face it—the concept of present perfect in American English is a tricky one. What does it mean, anyway? Some grammar experts have suggested that it's not really a tense—it's *aspect*. Since this is an unfamiliar concept to many of us (and our students), though, this may not help with tomorrow's lesson.

A practical view

The grammar concept is important for students to see—eventually. But when teaching beginners through intermediates, we like to focus mostly on *usage*. That is, in what situations do we actually use the present perfect in conversational English?

There are several key words that are often linked with present perfect—"how long?" for example, so "How long have you lived here?" is an obvious first lesson in this structure, that even beginners can do.

We like to focus on just one example of present perfect usage at a time, and practice it until the students are very comfortable with it. In this issue we include an interview activity that practices the present perfect with *ever*.

How to do it

Before handing out this interview sheet, check to see that the food items on the list are of interest to your students; if not you can use some 'white out' and change the list. The three blank spaces are for students to add their own items.

Students can do this activity in pairs, and then switch partners and repeat the interview as many times as there is time for.

Follow-up

Do a whole-group summary on the blackboard, to find out how many students have, or haven't, tried each food item. ➡

Interview about food.

Meet with some other students.
Find out which of these things they have eaten,
and which ones they haven't eaten. Ask:

"Have you ever eaten _____?"

	Name _____	Name _____	Name _____
	Yes No	Yes No	Yes No
pizza	<input type="checkbox"/> <input type="checkbox"/>	<input type="checkbox"/> <input type="checkbox"/>	<input type="checkbox"/> <input type="checkbox"/>
a cheeseburger	<input type="checkbox"/> <input type="checkbox"/>	<input type="checkbox"/> <input type="checkbox"/>	<input type="checkbox"/> <input type="checkbox"/>
pumpkin pie	<input type="checkbox"/> <input type="checkbox"/>	<input type="checkbox"/> <input type="checkbox"/>	<input type="checkbox"/> <input type="checkbox"/>
eggrolls	<input type="checkbox"/> <input type="checkbox"/>	<input type="checkbox"/> <input type="checkbox"/>	<input type="checkbox"/> <input type="checkbox"/>
fried rice	<input type="checkbox"/> <input type="checkbox"/>	<input type="checkbox"/> <input type="checkbox"/>	<input type="checkbox"/> <input type="checkbox"/>
kielbasa	<input type="checkbox"/> <input type="checkbox"/>	<input type="checkbox"/> <input type="checkbox"/>	<input type="checkbox"/> <input type="checkbox"/>
pirogis	<input type="checkbox"/> <input type="checkbox"/>	<input type="checkbox"/> <input type="checkbox"/>	<input type="checkbox"/> <input type="checkbox"/>
borsht	<input type="checkbox"/> <input type="checkbox"/>	<input type="checkbox"/> <input type="checkbox"/>	<input type="checkbox"/> <input type="checkbox"/>
_____	<input type="checkbox"/> <input type="checkbox"/>	<input type="checkbox"/> <input type="checkbox"/>	<input type="checkbox"/> <input type="checkbox"/>
_____	<input type="checkbox"/> <input type="checkbox"/>	<input type="checkbox"/> <input type="checkbox"/>	<input type="checkbox"/> <input type="checkbox"/>
_____	<input type="checkbox"/> <input type="checkbox"/>	<input type="checkbox"/> <input type="checkbox"/>	<input type="checkbox"/> <input type="checkbox"/>



'Photos with feeling'—student-generated photo stories

This is a wonderful activity for speaking, listening, writing and reading practice, and for vocabulary building. It will work fine with a multi-level group, and can be used for an hour lesson or expanded to two or three sessions.

Getting ready

Unlike many of the activities we've brought you, this one may require quite a bit of preparation on your part, collecting pictures. You need a collection of high-quality, expressive photos of people. They should each be mounted on a piece of poster-board, to protect them from handling.

Some sources for good, expressive photos are old *National Geographics* and old *Life* magazines (assuming you want to cut them up). Used bookstores sometimes sell these, as well as old photography books. "The Family of Man," for example, yielded many good pictures.

Choose photos with one or two people in them, and in which there seems to be something happening within the person. The photos should all evoke some kind of emotion. Have a picture ready for each student, with a few extra so there is a selection.

Start with vocabulary

Have the students generate a list of adjectives about feelings, and write these words on the board. Discuss this vocabulary as you go along. It's nice if you can put these into categories also, for example positive and negative feelings.

Now have each student select a photo from your collection, which you can have spread out on a table. Tell them to select one that they like. Once they have a photo, have them make a *list* of 5 words that apply to the photo, which they can select from the list on the board. (For beginners, 3 words is enough.)

Talk about it

Once they have thought about their pictures, have students pair up, and ask them to talk about their pictures together. Give them plenty of time to do this (10 or 15 minutes, longer if they are enjoying it.)

Imagine

Next, ask the students to prepare to write. Ask them to put themselves in the place of a person in their photo, by saying "Imagine you are this person! Tell me about yourself." (It helps to give an example by holding up a picture and saying a few things about it in the first

person.) Students will write a short essay in the first person. Tell them you will collect the papers when they are finished.

Give them 15 or 20 minutes to write, offering encouragement where needed. If any students have trouble starting, help them by posing some questions, for example: "Why is she crying? What happened?"

Matching stories to photos

When the students have finished writing, remind them to sign their papers. Have one student collect all the photos and display them in front of the room. Meanwhile, collect the students' papers, shuffle them, and redistribute them to the students.

Ask the students to read the story you have given them silently, and then to come forward and find the correct photo. Afterwards they will need to check with the author to see if they got it right. You can collect the papers again and redistribute them, repeating the 'matching game' several times.

Written dialog

The preceding activities are usually enough for one session. On another day, you could continue the exercise by again distributing the stories randomly to students. This time, ask them to write two questions for the author and then return the story to the person who wrote it. The authors now in turn respond in writing to the questions. This dialog can continue back and forth a few times, as students seem to really enjoy this activity.

Writing homework

A good homework assignment, especially for advanced students, is to ask them to write a *new* story about the same picture, this time in the third person, incorporating the questions that came up in the written dialog.

Follow-up activities

Listening—The teacher could read the essays aloud to the class, giving all the students a chance to hear the stories, and have the class find the matching photo for each one (and guess who wrote the story!).

Speaking—On another day, after everyone has heard all the stories, the teacher could distribute randomly just the photos to the students. Each student can tell the class what he or she remembers about the story. ←

Idea file

Special thanks: The idea and inspiration for this activity first came from Judith Dancoff, writer and ESL teacher.

'Photos with feeling'

Purpose: Practice all skills.
Level: Useful for any level; works with multi-level group.
Time: At least an hour, more if desired.
Materials: A set of good, expressive photos of people, mounted.

Preparation:

1. Generate a list from students of adjectives about feelings; discuss if necessary. Groups words on board by category.
2. Have students select one photo each.
3. Have each student write down 5 adjectives that apply to his or her photo.
4. In pairs, have students talk about their photos (10-15 minutes)

Writing & matching game:

5. Have students write a short essay about their photos, in the first person (15-20 minutes).
6. Give students assistance as they write.
7. Collect all the photos; display in the front of the room.
8. Have students sign essays.
9. Collect essays; distribute randomly.
10. Have students locate correct picture for story; check answer with author.
11. Redistribute essays and repeat matching game as desired.



Follow-up: (for subsequent sessions)

Written dialog:

1. Distribute essays randomly to students again.
2. Have each student write to questions for the author; return paper.
3. Have authors respond in writing & return to questioner.
4. Continue written dialog with one or two more exchanges.

Writing homework:

5. Students re-write essay in third person.

Listening:

6. Teacher reads original essays aloud to entire class.
7. Students find matching photos; guess authors' names.

Speaking:

8. Teacher distributes photos only, randomly to students.
9. Students tell class about photo, recalling what they can from original story, adding more if they like.

(told here)

Group work:

A conversation wheel

Here's an activity that's easy to plan. You can use it as a 15-minute warm-up, just to get students talking, or as a lengthier discussion exercise. You can adapt the vocabulary so that any level of student can play.

Preparation

For each group of 3-4 students make a copy of the wheel and cut out one pointer. (See page 7.) It's best if you use a very stiff piece of paper, or glossy cardboard. Punch a sizeable hole in the pointer, as marked (using one end of a 3-hole punch).

Center the pointer on the wheel, and stick a push-pin into the wheel, with an eraser, piece of cork or heavy cardboard under everything to anchor the pin firmly. Now the pointer should move easily.

The vocabulary

The vocabulary on this conversation wheel is suitable for an intermediate level group. If you have beginning level students, you could substitute some simpler vocabulary, such as: good, bad, interesting, sad, easy, important, nice. For advanced level students, try words like: amusing, challenging, strange, confusing, comfortable, depressing, frightening. (Once students are familiar with this game, you could also give them a blank wheel and have them think of their own categories.)

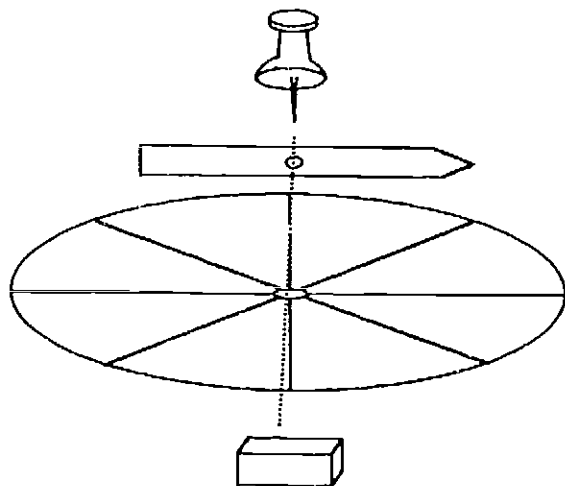

How to do it

Make sure the students know all the vocabulary on the wheel. Then write on the blackboard: "Tell about something that's. . ."

You should give an example or two to the whole group, such as "I think TV is relaxing."

Now the students will take turns spinning the pointer and responding within their groups. Answers can range from a one-word response to a sentence or an anecdote, depending on the students. If some students have trouble getting started, encourage them to give an example.

Follow-up

As a whole group, the class could compile a list of things for each category and put them on the blackboard. This can be a good way to expand their vocabulary, and reinforce the concept of the adjective.

As an individual writing exercise, students could choose one of the words from the wheel and write about it.

Why it works

This activity gives students some general conversation practice, but can also provide a chance for them to share some of their personal opinions with each other.

For a multi-level group, this activity is ideal. Advanced students have a chance to explain something in a non-threatening environment, while the lower-level students learn from listening, and from participating at their own level. ➔

Index to articles in *Hands-on English*, Volume I.

Adjectives

A categories worksheet. I-5, p.8

Advertisers

American English Publications. I-4, I-5

Educational Showcase. I-6

International Linguistics Corporation. I-3

Linmore Publishing. I-5, I-6

Literacy Volunteers of America. I-3

Assessment:

The ESL student progress chart -an informal assessment tool. I-3, p.6

Authors

Best, Linda:

Directing students to evaluate their own work. I-2, p.8

Freewriting—getting the ideas out. I-3, p.9

'Scribes' help students to learn. I-1, p.10

Brown, Jennifer:

The apartment building—who lives where? I-4, p.6

Campbell, Karen:

'Mapping' for vocabulary. I-1, p.5

More about 'mapping.' I-2, p.12

Thorington, Linda:

An American social event: the banquet. I-1, p.9

Cultural activities:

An American social event: the banquet. I-1, p.9

Famous Americans: an information-gapping activity. I-5, p.1

A religions crossword puzzle; ideas for activities. I-2, p.4

Dilemmas

Multi-level classes. I-4, p.9

A shy student. I-3, p.12

Editorials

ESL is not remedial. Publicimage of ESL. I-4, p.1

A helping hand for you. Intro to *Hands-on English* I-1, p.1

Listening to history. Sounds of Russian on U.S. airwaves. I-3, p.1

Official English vs language rights. The English Only debate. I-6, p.10

Oops—wrong gesture. Bush in Australia. I-5, p.9

Games (see also Puzzles)

Categories word game. I-4, p.2

Irregular verbs board game. I-4, p.5

Just-a-Minute guessing game (review). I-1, p.12.

Low-tech 'Storyboard.' I-4, p.5

Word Ways Cubes (review). S, p.4

Grammar

Adjectives: A categories worksheet. I-5, p.8

'Have you ever eaten pizza?' A present perfect activity. I-6, p.2

'Here's what I want you to do.' *want* + object + infin. I-3, p.8

Irregular verbs board game. I-4, p.5

'Let's start a business!' *If / would* construction. I-2, p.3

What have they been doing? Pres. perf. continuous worksheet. S, p.8

Group work

Cartoon dialogs—an all-skills activity. I-1, p.7

Famous Americans: an information-gapping activity. I-5, p.1

Interview for getting to know each other. S, p.5

'Strip stories'—a challenging listening activity. I-1, p.2

Holidays:

4th of July: Word find. I-1, p.8

Graduation: An American social event: the banquet. I-1, p.9

Presidents' Day: Famous Americans information-gap activity. I-5, p.1

Religious holidays: A religions crossword puzzle. I-2, p.4

Idea file (Ideas on 4x6 cards)

Cartoon dialogs—an all-skills activity. I-1, p.7

'Ice-breakers' for new students. I-3, p.3

Photos with feeling. Student-generated stories. I-6, p.4

Read and tell. Reading fluency and conversation. S, p.2

Variations on a reading text. I-2, p.9

What happens next? Prediction activity. I-5, p.7

If / would construction: 'Let's start a business!' I-2, p.3

Information for contributors

How to submit an article to *Hands-on English*. I-1, p.6

Irregular verbs

Irregular verbs board game. I-4, p.5

Mini-grants

Announcement. I-4, p.11

Q & A about the Mini-grants. I-5, p.12

Organizing:

Organizing all that ESL stuff. I-2 p.6

Present perfect: 'Have you ever eaten pizza?' interview. I-6, p.2

Present perfect continuous: What have they been doing? worksheet. S, p.8

Puzzles:

About health. Multi-level crossword. S, p.6

Citizenship puzzle. Multi-level crossword. I-6, p.1 & 9.

4th of July: Word find. I-1, p.8

Looking for a job. Multi-level crossword. I-5, p.4

A religions crossword puzzle. I-2, p.4

Reading

Variations on a reading text. 15 lessons in one. I-2, p.9

'What happens next?' Directed reading-thinking activity. I-5, p.7

Reviews (On the market)

The ESL Miscellany. *Pro Lingua Associates*. I-3, p.2

Just-a-Minute. *Eardley Publications*. I-1, p.12

Talk about Trivia. *Longman*. I-4, p.4

Whaddaya Say? *Prentice-Hall Regents*. I-2, p.2

What's the Story? *Longman*

Publishing Group. I-6, p.11

Word Ways Cubes. *Alemany Press*. S, p.4

Speaking/Conversation

Controversy cards. A discussion activity. I-2, p.10

Conversation wheel. I-6, p.6

Find someone—questionnaire. I-3, p.4

'Ice-breakers' for new students. I-3, p.3

Interview for getting to know each other. S, p.5

Interviewing with one student. S, p.12

National Geographic as conversation starter. I-4, p.10

'Strip stories'—a challenging listening activity. I-1, p.2

Vocabulary:

'Mapping' for vocabulary. I-1, p.5

More about 'mapping.' I-2, p.12

want + object + infinitive 'Here's what I want you to do.' I-3, p.8

Writing:

Controlled composition: An accident. I-4, p.8

Directing students to evaluate their own work, a checklist. I-2, p.8

Freewriting—getting the ideas out. I-3, p.9

'Scribes' help students to learn. I-1, p.10



Conversation wheel

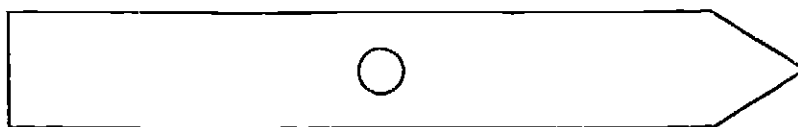
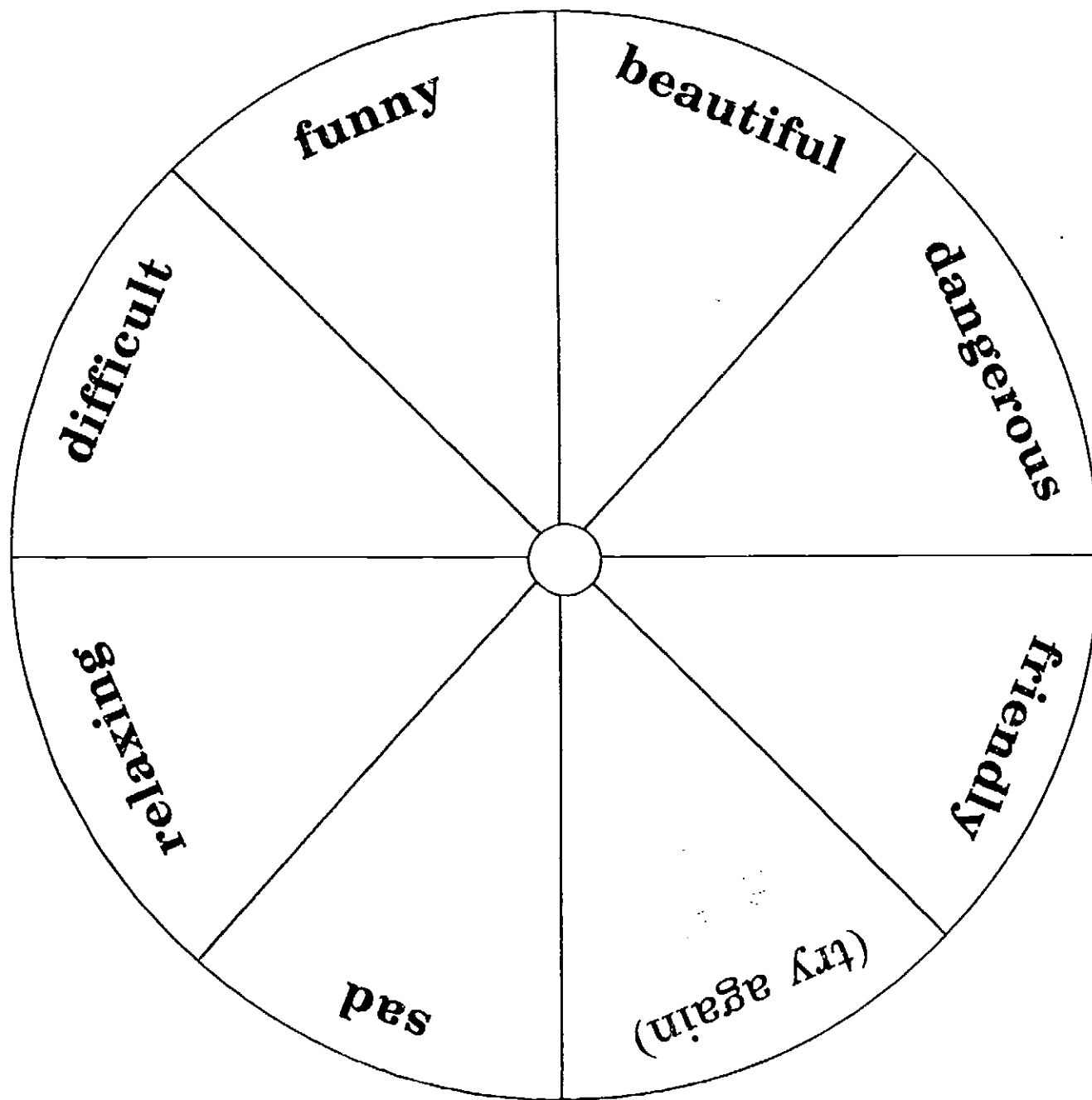

Hints & tips

Got an idea that works for you? Maybe you'd like to share it with other readers! ESL teachers and tutors are always looking for ideas to try out with their students.

Where's the teacher?

Try "hiding" in a back seat and let your students take over the class. This keeps down the "teacher talk" and gives you a chance to assess the students' strengths and weaknesses.

Suggested by Karin Guardia, who teaches at 3 different sites for the Adult Learning Center, BOCES of Southern Westchester, New York.

Guessing game

Here's a way to review the names of fruits and vegetables, that students have fun with. Hide one vegetable or fruit at a time under a sheet, and have the students guess what it is. This provides lots of practice with formulating questions, and with vocabulary.

Suggested by Judy Wine, who teaches at 2 different sites for the Adult Learning Center, BOCES of Southern Westchester, New York.

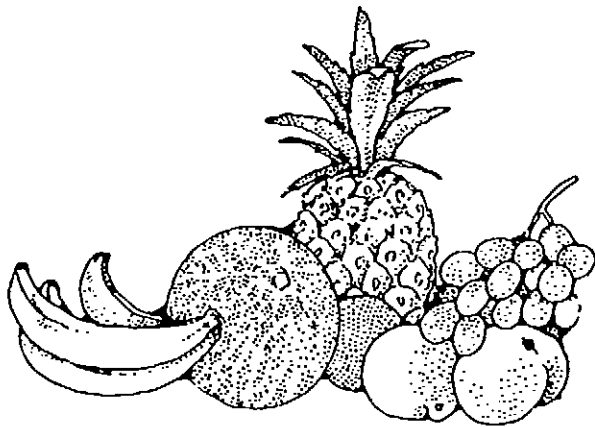

"Kim's game"

There is a variation of the guessing game above which is called "Kim's game." Students look at a group of objects for a short time, then the objects are covered up with a sheet. The students try to recall as many objects as they can and write the names down. Then they get to see the objects again. This is partly a memory game and partly a vocabulary review. For some ideas on how to play this see *Games for Language Learning*, Cambridge University Press.

Phone talk

If students seem shy or hesitant to speak with each other in class, bring in some telephones as props. Have the students conduct dialogs, interviews or discussions over these 'telephones.' This changes the focus a little and reduces self-consciousness.

Related to us by Jim Tarvin of Middletown, NY, who worked with Japanese students in Hawaii.

A tutor on tape

Janet Mannon, a tutor with the LVA program in Front Royal, Virginia, works with a man who is seventy-two years old. She wrote:

What has worked so well for us is I record his lessons. I started doing this when I was going to be away for three weeks. It enables him to learn at his own pace. He doesn't need anyone available to ask questions. It gives him independence. In the beginning I used my recorder, letting him take it home. Later he was given one by his son.

I record the stories from the book, exercises that were on a television series, anything I want him to learn. In the beginning I had to speak slowly, but am now able to go a little faster.

When I'm away, I am still very much in touch with my student through my recordings.

A photo wall

Here's an idea that worked well in a Refugee program where students came and left at a dizzying pace. The photo wall provided a sense of 'class history.'

Set aside a wall or bulletin board as a permanent location. Divide this area into two sections, one labeled "ESL class" and the other labeled "former students." As each student enters the program, take a Polaroid picture of him or her and label it with the student's name and country. Post it on the wall. When the student graduates, or leaves the program, move the picture over to the "former students" section.

You'll find that this gives the students an opportunity to get to know each other more easily. It also makes it easier for the class to talk about students who have left, as they can find the picture on the wall. Sometimes it is helpful for nervous newcomers to see a relative, friend, or countryman's face among the pictures in the classroom. ➡

Citizenship puzzle

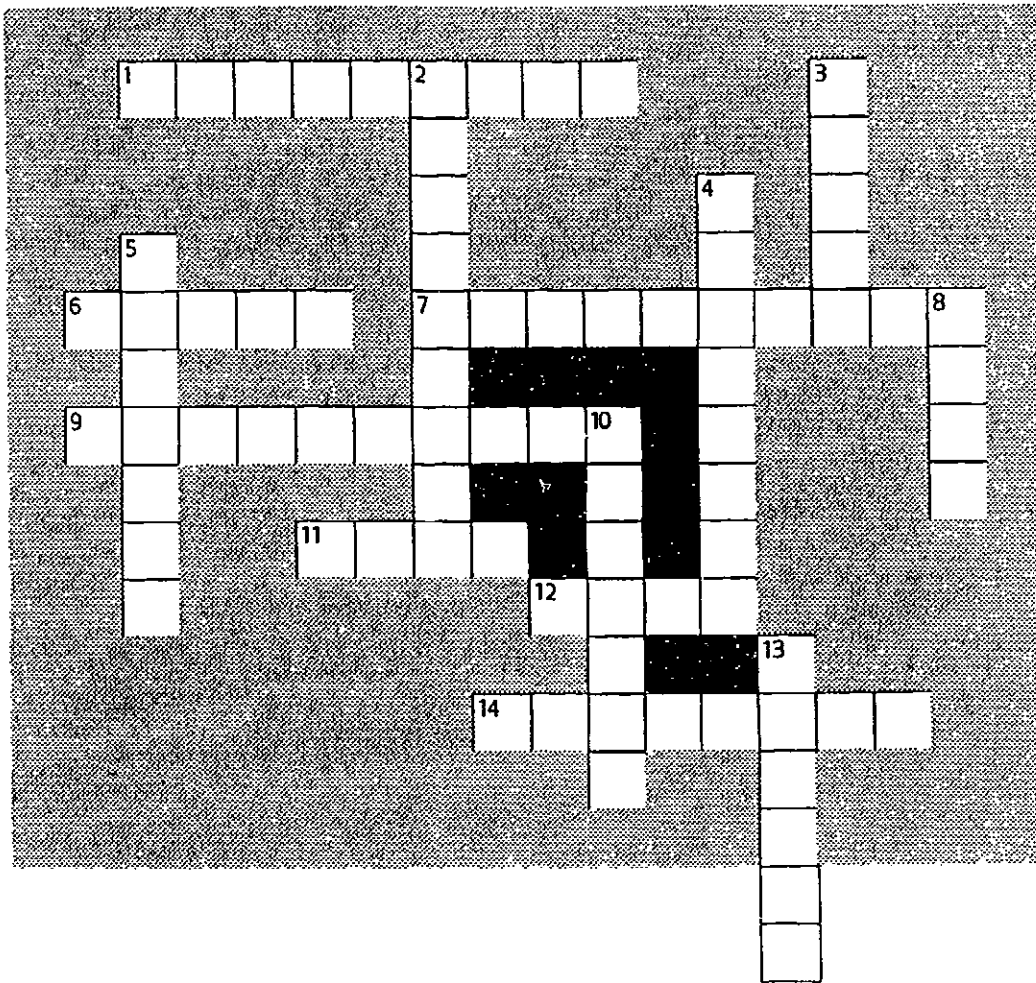

Across clues

1. To become a citizen, you first have to answer some _____ about this country.
6. You must be at least 18 _____ old before you can become a new citizen.
7. In the U.S., the President is the head of the _____. In Canada it is the Prime Minister.
9. In a _____ government, the people choose their leaders by voting.
11. Only citizens can _____ for candidates in an election.
12. If you _____ in this country for 5 years, you can apply for citizenship.
14. When is the next _____, when the people will vote?

Down clues

2. An _____ is a newcomer to the country.
3. When you become a citizen, you will meet with a _____ for an interview.
4. You probably will have to learn to speak a new _____ to become a citizen.
5. _____ laws are laws that are true for all of the country.
8. If you want citizenship, you will have to take a _____ about history and government.
10. A person who has all the rights and privileges of this country is a _____.
13. The things a citizen can do are his or her _____. For example, voting, or running for office.

Word list: citizen, democratic, election, federal, government, immigrant, judge, language, live, questions, rights, test, vote, years.

'Official English' vs language rights

We want to call your attention to a bill now in committee in the U.S. House of Representatives that would make English the official language of government.

Although on the surface of it this may seem a logical idea, the motive behind it, we feel, is to exclude language minorities such as Spanish speakers from participating in public life.

The 'official English' bill is the result of the English Only movement, which was started more than 10 years ago by a group called *U.S. English*, and includes other groups such as *English first*. They have succeeded in getting restrictive language laws passed in some U.S. states. Federal legislation of this type has been proposed several times in the past, but never enacted.

This most recent bill, HR 123, has a slightly better chance of succeeding since it would restrict language use to English just in government activities. To many Americans this seems reasonable, and the bill seems to be gaining support in Congress.

Many civil rights groups, however, as well as religious groups and teacher's organizations oppose this kind of legislation. They worry that after bilingual services, bilingual education will be targeted next. And they fear that racism and intolerance will grow in a climate of exclusion.

The concept of "English Plus" (strong English proficiency plus second language) was developed as a response to the English Only movement. "English Plus" incorporates the idea of cultural and democratic pluralism as an important value in our society.

TESOL, the organization for Teachers of English to Speakers of Other Languages, has a strong statement opposing official English, and affirming "the right of all individuals to preserve and foster their linguistic and cultural origins."

We at *Hands-on English* feel that restrictive language laws will lead to discrimination and exclusion of the immigrants in our society. We hope you will join us in speaking out against this bill. ☛

The editor mailed a copy of this letter to her Congressman. It is included here as an example. Please take 10 minutes now and write a letter to *your* Representative in Congress and/or Senators.

If you would like more detailed information on this issue, write to the English Plus Information Clearinghouse:

EPIC
220 I Street NE, Suite 220
Washington, DC 20002
phone: (202) 544-0004

They have a very interesting packet of information, and also publish a newsletter called "EPIC Events."



P.O. Box 589, Dewitt, NY 13214, USA

A periodical for teachers and tutors of adult ESL

Anna Silliman, editor

March 25, 1992

The Honorable James T. Walsh
U.S. House of Representatives
Washington, DC 20510-4703

Dear Congressman Walsh,

I understand that you are one of the co-sponsors for HR 123, the 'English as Language of Government Act.' I would like you to know that I **strongly** oppose this legislation, and any legislation like it which attempts to make English the "official language" of our country.

Although this bill may not be as comprehensive as similar bills proposed in the past, it would still serve to further disenfranchise language minorities. It is discriminatory, and if passed, would open the door to even more dangerous restrictions on language rights.

As an English as a Second Language teacher to adults for many years in the Syracuse area (I taught at the Refugee Assistance Program and at the SUNY-Educational Opportunity Center), I know from personal experience that immigrants already want to learn English. Unfortunately there are not enough programs to meet the demand. Existing ESL programs for adults are overcrowded and underfunded.

Throwing more legal obstacles in the path of limited English speakers will not make it any easier for them to get the instruction they need.

I urge you to reconsider your support of this bill, and (if it comes up for a vote) to vote NO on HR 123. Thank you.

Since rely,

Anna Silliman
Anna Silliman

EDUCATIONAL SHOWCASE

Your ESL Connection

Providing ESL/EFL Programs for All Ages

The Largest Collection of ESL Materials
on Display in the Midwest

- * Place orders by mail or fax: (313) 680-1052
- * UPS delivery in 5 to 10 days of in-stock items
- * We meet publisher's prices AND beat the service
- * To order or to receive our comprehensive ESL catalog write to:



EDUCATIONAL
SHOWCASE
1334 Wheaton Street
Troy, MI 48083
(313) 680-0860

Linmore Publishing

STARTING TO READ

Linda Mrowicki



A teachers' press..

Call or write for our catalog:
Linmore Publishing
Box 1545
Palatine, IL 60078
(800) 336-3656

News & notes



Conference in Canada

Hands-on English exhibited at the TESOL conference early this March in beautiful Vancouver, British Columbia. As a result we are welcoming many new subscribers from the U.S. and Canada. Let us hear from you!

Peace Corps expanding

The Peace Corps is planning to send volunteers for the first time to regions in what was the Soviet Union, now called the Commonwealth of Independent States. By this summer or early fall there may be volunteers in Latvia, Lithuania, Estonia, Armenia and the Ukraine. Peace Corps volunteers now also go to Bulgaria, Czechoslovakia, Poland and Albania, as well as Asia, Africa and the Pacific. Call for more information at 1-800-424-8580 ext. 2293.

Happy 30th, LVA!

Literacy Volunteers of America is 30 years old this year. Many LVA tutors across the country work with ESL students, providing a valuable service with small-groups or individuals. (Call LVA at 315-445-8000)

Last call for Mini-grants

Hands-on English is offering a small number of grants of up to \$100. each for an instructional project. Deadline for applying is April 30, 1992. Write to us for an application: *Hands-on English*, P.O. Box 589, Dewitt, NY 13214 USA.

Oops! Oops!

Sharp-eyed reader Tom Mueller noticed that our editorial about U.S. President Bush's visit to Australia was not completely correct. He tells us that the "V" for "Victory" sign we are familiar with here actually has the same meaning in Australia. Only when the hand is rotated 180 degrees does the meaning become, well, obscene. A good reminder to our students: it pays to be careful with gestures.



Citizenship week

April 12 to 18 is National Citizenship Week in Canada. (The U.S. has Citizenship Day on September 17th, during Constitution Week.)

On the market

Reviews of useful ESL materials

"What's the Story?—Sequential Photographs for Language Practice" by Linda Markstein and Dorien Grunbaum (1981 Longman Publishing Group). Set of 4 Wallcharts \$79.95, Workbook Levels 1-4 \$8.95 each, Teacher's Manual \$10.95.

Do you teach multi-level groups of students? Do they need more opportunities for speaking in class? Does your program still have a book budget? If you answered yes to these questions, we can heartily recommend *What's the Story?* as one of the most useful and flexible teaching supplements we know about.

The wallcharts are large photographs with interesting and evocative pictures. Each set of four pictures tells a story—but exactly how the story goes is up to the creative interpretation of your students. Over the years, we've used these pictures with many students, beginner through advanced level, and they always seem to find something new.

Our favorite way to use these photos is first to discuss them one by one with the whole class to generate the vocabulary, and then to divide up into groups of 3 or 4 students. Each group

then discusses the pictures and works out a story line, then presents their version of the story to the class.

The student workbooks are useful for follow-up activities in reading, writing and grammar, and are available at four different levels. One caution: the exercises are harder than they look, so check them carefully before deciding to use them with your students.

Finally, unlike most teacher's manuals, this one has useful information, model stories and some good teaching ideas which will help you to use the materials creatively.

If you are tutoring one student or a small group and don't have the wallcharts available, you can use the small photos included in each workbook for the same purpose. ←

Confused about where to order? Try Educational Showcase (313) 680-0860. They are an ESL store in Michigan that carries materials from many publishers, and they can ship you what you need.



A periodical for teachers and tutors of adult ESL
P.O. Box 589
Dewitt, NY 13214
USA

BULK RATE
U.S. POSTAGE
PAID
SYRACUSE, NY
PERMIT NO.764

ADDRESS CORRECTION REQUESTED

March/April issue

77



Hands-on English

A periodical for teachers and tutors of adult English as a second language

Promoting democracy

Shortly after the riots in Los Angeles, we telephoned a friend who teaches ESL there for a firsthand report. She told us that it was, indeed, an intense and traumatic time. One of her students had been injured, and all the students were very distressed, she noted. Several of the Korean students were overwhelmed by the personal suffering of their families. It was impossible, she said, for anyone, teachers included, to think about anything else.

With regards to prejudice, our friend had three suggestions of things we as teachers can do in the classroom to help create a more democratic society:

First, discussing **stereotypes** with the students may help to put some things in perspective. Explicit talk about the perceptions and misperceptions we have about each other can be enlightening.

Second, discussing ways to recognize and deal with discrimination could help our students. Many school districts have ready-made units on discrimination that could be adapted, and which might be very informative.

Third, generating multicultural awareness is a big step in the right direction. Think of your classroom as a mini-United Nations, and help the students to value and respect each others' cultures as well as their own and ours. (*Hands-on English* sometimes has exercises that promote a multicultural approach—see page 2 in this issue, for example.)

We believe that the teacher can create a democratic environment in the classroom, that can spill over into the real world. It's certainly worth a try. ➔

We're one year old!

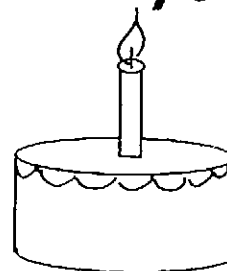

Just over a year ago we launched *Hands-on English*. We now have nearly 500 readers, in 45 different U.S. States, 5 Canadian provinces and even in Japan.

So far your comments have been very encouraging—we've heard from many that the material is useful. Let us know if you have ideas or suggestions!

Oh, and—spread the word. Thanks!

Contents:

Crossword puzzle:	
- "A summer picnic"	2
Grammar grab-bag:	
- Practice with <i>can</i> and <i>could</i>	4
Cultural activity:	
-English names and nicknames.....	5
Tools & techniques:	
-The 'One question interview'.....	6
From the field:	
- Testing . . . a lighter look	8
Hints & tips	9
On the market:	
-Placement tests;	
-Review of an ESL resource book.....	10
News & notes	12

Hands-on English (ISSN 1056-2680) is published six times a year (Jan./Feb., March/April, May/June, July/Aug., Sept./Oct., Nov./Dec) by Hands-on English, P.O. Box 589, Dewitt, NY 13214 USA.

Copyright © 1992 Hands-on English

Subscription rates:

\$16 for regular subscribers,
\$10 (discounted rate) for volunteers or teacher's aides, \$22 (multi-user rate) for libraries or institutions. Single copies are \$4 each. **Postage & handling:** Canada and Mexico add \$4; outside N. America add \$10.

Permission to photocopy: This periodical is copyrighted. However, we invite teachers and tutors who have a paid subscription (or whose institution has a paid subscription) to make as many copies as they need for their own classroom use.

Please don't make copies for colleagues! We survive on the subscriptions of our readers.

Editor: Anna Silliman
(M.A., Teachers College, Columbia Univ.)

Address correspondence to the editor.
Hands-on English, P.O. Box 589, Dewitt, NY 13214 USA. Or call (315) 445-0785.

Subscribe today!

Send this form with your check or money order (U.S. funds only) to the above address.

Please send me a subscription to *Hands-on English* for one year (6 issues). I enclose:

- \$16 for a regular subscription
- \$10 discounted rate for a volunteer or aide
- \$22 multi-user rate for a library/institution
- postage/handling: Canada/Mexico add \$4.
- Countries outside N. America add \$10.

Name: _____

Address: _____

Institution: _____

Position: _____

II-1

Crossword puzzle:

A summer picnic

The multicultural origins of food

Here's a crossword puzzle designed to draw your students' attention to the rich cultural background of many common foods.

How to do it

Have the students read and discuss the story about a summer picnic first. If much of the vocabulary is new to them, you might bring in some pictures also.

For beginning level students, it helps to put the vocabulary into categories first, before starting the puzzle. For example, have them list all the vegetables they find in the story, then list all the fruits, then all the beverages. This will simplify looking for the answers later.

Tell the students that the answer to each clue can be found in the story. Even if they don't know the answer, by process of elimination they should be able to figure it out. This activity is good for small groups, as students can pool their background knowledge.

Follow-up

You can discuss each food item in the puzzle with your students in terms of their own cultures. For example: "Do bananas grow in your country? Do people in your country eat bananas? Why or why not? How do you prepare bananas in your country? When do you eat them?"

Why it's important

The puzzle helps to convey the idea that our culture owes much to its past immigrants, and that there are global and historical connections even in the everyday things we use.

For new immigrants, understanding this relationship may give them a small but positive way to connect to our culture. They can be proud of the contribution their country or culture has made.

Puzzle key:

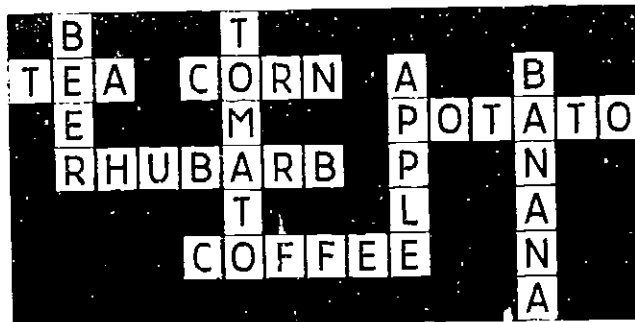

Crossword puzzle: A summer picnic

Every summer, my family has at least one big picnic. We call our relatives, and some close friends, and decide on a date, usually in July. We all meet at a nearby park, and everyone brings food.

The men are in charge of grilling the hamburgers and the barbecued chicken. While they do that, the women set out all the food on picnic tables. There is potato salad, sliced cucumbers and tomatoes, and potato chips. If it's late in the summer, of course we have corn on the cob. Somebody always brings hamburger buns, ketchup and mustard.

Under the table, where it's shady, we put a big cooler of ice to keep the beer and soda cold. There's also a big pitcher of iced tea.

For dessert there is fresh apple pie or rhubarb pie, or maybe a fruit salad with Jello, bananas and grapes. Somebody usually brings a thermos of coffee to have with dessert.

I love a summer picnic—I don't know why, but food always seems to taste better when you eat it outside.

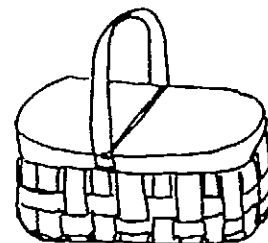
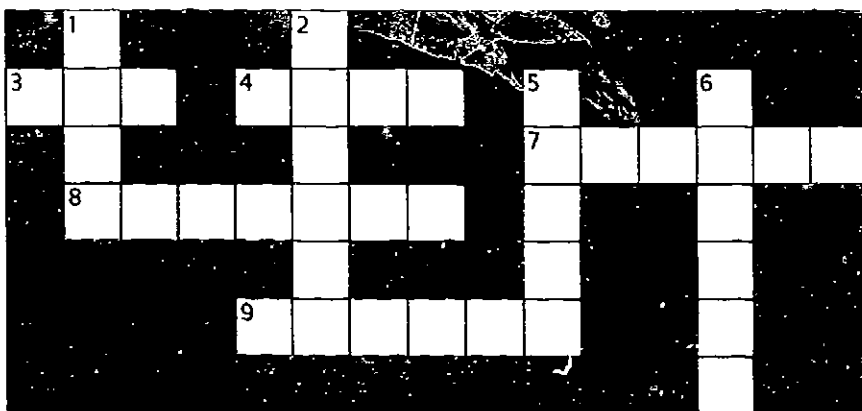

Across clues

3. A drink, made from a native Southeast Asian plant. This drink was already popular in China and Japan hundreds of years ago. Italian traders brought it to England, where it was also very popular. Later English immigrants brought it with them to America.
4. This vegetable comes from a plant that grew in Central America more than 3,000 years ago. The Incas, Mayas and Aztecs all used this food. Today it is one of the most important food crops in the world.
7. This vegetable first grew in Central America. Spanish explorers brought it to Europe in the 1500's. In Europe it became a very important food, especially in Ireland. Irish immigrants brought it with them to America in the 1700's. Now it grows almost everywhere.
8. This plant came from Siberia. It was first brought to America by Europeans in the 1800's. The taste is very sour, but we eat it as a fruit with sugar or honey.
9. A drink, made from an African plant. Arabs brought it to the Middle East. Now it grows in Brazil, and people all over the world drink it.

Down clues

1. A drink that was first made in 3,000 B.C. in Babylon, in the Middle East. The Romans didn't like this drink, because they preferred wine, but they brought it to Europe where it became very popular. German and Czech immigrants made this drink very popular here.
2. This vegetable is native to the Andes mountains in South America. In the 1500's, Spanish conquerors brought it back with them to Europe. It was a very popular food in Italy, but in other countries people were afraid to eat it! They thought it was poisonous. In the 1800's, Thomas Jefferson was one of the first Americans to eat this vegetable.
5. This fruit first grew in the Mediterranean region. It is a very old fruit. It grew in many areas of Asia, the Middle East and Europe, but didn't come to the New World until the 1600's. The Pilgrims brought it with them when they came from England. Today you can buy more than 100 different kinds of this fruit.
6. This sweet fruit first grew in India thousands of years ago. It came to Africa 2,000 years ago, and then to the Americas in the 15th century.



"Now I can, but before I couldn't."
Modals of ability in past and present.

Here is a fairly simple and straightforward exercise for practicing can, can't, could and couldn't in context. It's good for high beginners or low intermediate students, but more advanced students will also enjoy participating.

Preparation

Make sure the students already understand the four modals. A good preparatory lesson (for the day before) is to have students list all the things they *can* do and *can't* do, and discuss these. This is also a good way to learn more about the students, and to give some recognition to their abilities.

How to do it

Read the sentences about Mr. and Mrs. Jones together and discuss them. Ask the students to contribute further examples about the Joneses, using the structure given as a model.

Next, have students fill in some answers about themselves in the four exercise questions. Keep in mind that the questions may take some thought, so allow the students plenty of time to work. It's nice if they have more than one answer for each question—you can encourage this by assigning only one question at a time.

When students are ready, discuss everyone's answer for each question. This makes for a very interesting, personal discussion, and gives all the students plenty of practice in using these structures.

Why it works

With many grammar exercises, students can just plug in the correct answer without understanding it, but in this one they have to understand what they are saying. The content is thoughtful.

And, even though the grammar structure itself is fairly easy, the sentences are complex. This gives even beginning students a chance to practice saying adult-sounding sentences with their own adult content.

Adapting the lesson

If you have more advanced students in the class, you could have them substitute the structure *was/wasn't able to* in the exercise. You could also encourage them to explain *why* as part of their answer.

Follow-up

At the next session, try giving a dictation using the structures practiced here. (You could write some examples about yourself for the dictation.) The students should now be familiar with the structure, so encourage them to listen to an entire sentence before beginning to write.

Don't give the dictation word-by-word, but rather read each sentence smoothly at natural speed, pausing between sentences for the students to write, repeating as many times as needed. The idea is to develop listening fluency. 



Mr. Jones is 67 years old.
When he was young, he could dance very well,
but now he can't.



Mrs. Jones is retired.
When she was working, she couldn't travel to see
her friends, but now she can.

About you:

1. When I was a child, I couldn't _____, but now I can.
2. Now I can't _____, but when I was younger I could.
3. When I lived in my country, I could _____, but now I can't.
4. In this country I can _____, but in my country I couldn't.

Cultural activity:

English names and nicknames

Special thanks to Joan Uchitelle, ESL teacher at BOCES Adult Learning Center, Valhalla, NY for contributing this information.

Nicknames exist in all languages. In English, nicknames are usually made by *shortening* the proper name. Sometimes the final consonant is doubled before a -y or -ie is added.

Here are two lists of English proper names, one for women and one for men. Find the correct nickname for each one. Write it in the blank space next to the proper name.

(These are only a few examples—there are many, many more names in English!)

Women's names

1. Alexandra _____
2. Amanda _____
3. Barbara _____
4. Beverly _____
5. Catherine (or Katherine) _____
6. Christine _____
7. Constance _____
8. Deborah _____
9. Diane (or Diana) _____
10. Dorothy _____
11. Elizabeth _____
12. Emily _____
13. Florence _____
14. Jacqueline _____
15. Janet (or Janice) _____
16. Jennifer _____
17. Jessica _____
18. Joan (or Joanne) _____
19. Judith _____
20. Linda _____
21. Margaret _____
22. Marjorie _____
23. Miriam _____
24. Patricia _____
25. Rebecca _____
26. Roberta _____
27. Sandra _____
28. Susan _____
29. Teresa _____
30. Virginia _____

Men's names

1. Andrew _____
2. Anthony _____
3. Benjamin _____
4. Charles _____
5. Christopher _____
6. Daniel _____
7. David _____
8. Edward _____
9. Eugene _____
10. Frederick _____
11. Gerald _____
12. Gregory _____
13. Henry _____
14. James _____
15. Jeffery _____
16. John _____
17. Joseph _____
18. Kenneth _____
19. Lawrence _____
20. Louis _____
21. Michael _____
22. Patrick _____
23. Phillip _____
24. Richard _____
25. Robert _____
26. Samuel _____
27. Stephen _____
28. Theodore _____
29. Thomas _____
30. William _____

Nicknames: Becky, Lynn, Flo, Debbie, Barb (or Babs), Mimi, Terry, Sandy, Bev, Connie, Marge, Sue (or Susie), Patty, Alex (or Sandy), Jenny, Jackie, Cathy (or Kathy), Chris (or Christy), Jo, Jan, Di, Em, Peg (or Maggie or Meg), Mandy, Bobbi, Ginny, Jessie, Judy, Dotty, Liz (or Betsy, Bess, Betty or Libby).

Nicknames: Larry, Dick (or Rich), Bill (or Will), Sam, Ken, Bob, Mike, Steve, Dave, Charlie (or Chuck), Joe, Tom, Pat, Ted (or Theo), Ed, Ben, Tony, Dan, Jeff, Greg, Lou, Andy, Chris, Jack, Jim, Phil, Harry (or Hank), Gene, Jerry, Fred.
(Note: Sometimes these nicknames can also have a -y or -ie added at the end. For example: Tommy.)

One question interview

We are pleased to present this activity by Fiona Armstrong, Adult Basic Education, New York City Public Schools. We saw her present it at the 1991 New York State TESOL conference in Albany, N.Y.

We think this activity could go into the repertoire of just about every ESL instructor. It provides good, repeated language practice with one structure, and yet remains intrinsically interesting because it is real communication. For that reason it is particularly useful for beginning-level adult students, but it's adaptable for any level. Use it as a lead-in exercise for a new topic, or use it for review.

Overview

Each student has one question, which he or she asks, survey-fashion, of all the other students. This is done by circulating among the group and interviewing each other one by one. The students note down the different answers they get, then summarize the results.

Preparation

1. Think of a theme and create questions (or have the students create questions) in relation to that theme. Write enough questions so each student has one.
2. Create interview sheets by putting each question at the top of a separate sheet of paper. Then write numbers down the side from 1 to the number of students in the group.
3. Assign a number to each student in the class.

Present an example

4. Draw a model sheet on the board. Write an example question at the top. Ask each student in the group this question, and record the answer next to each student's number.

Where are you from?
1.
2.
3.
4.
5.
6.

5. Ask the class for a summary of the answers, or discuss the results. (For example: "Three students in the class come from Poland and three from Korea.")

Start the action

6. Ask everyone to stand up with their interview sheet, walk around and survey their classmates, writing the answer next to the respondent's number.
7. Assist the students as they work. Make sure students ask the question orally and do not simply exchange papers.
8. As people finish interviewing, have them prepare a summary of their data. This can take the form of a written summary on the board and/or an oral summary. (Help students with the appropriate summarizing language when needed.)
9. Have students present their findings to the group and discuss the results.

Adapting the activity

For larger groups, students could work in pairs, with each pair assigned one interview question. Alternatively, the group could be divided in two, with each group working on the same set of questions.

In a multi-level group, each student can work on a question appropriate for his or her own language level. That is, the questions can vary in their complexity.

Incorporate a non-literate student by teaming him or her up with a literate student who can serve as note-taker.

Why it works

This is an adult activity that generates lots of purposeful communication. Students become 'invested' in their own interview question, making the task both meaningful and fun for them.

The activity also has the important effect of bringing a diverse bunch of students together by defining an 'identity' for the group. In the long run, such a feeling of unity will help to improve the learning environment for everyone.

(See the next page for some sets of example questions for the One question interview.)

One question interview: Some example questions

Laundry questions

(by Elaine Gleiberman)

- Who does your laundry?
- Where do you do your laundry?
- Do you separate dark and light clothes?
- Do you use bleach?
- Do you use softener?
- What kind of detergent do you use?
- Where do you dry your laundry?
- Who folds your laundry?
- What do you do while your clothes are being washed?
- How often do you do your laundry?
- How many people's laundry do you do?
- Do you watch ads about laundry on TV?
- Do you use hot or cold water?
- How much does it cost to do your laundry?
- How much detergent do you use?
- How did you do laundry in your country?

Hint: For a picture story about doing laundry, see Action English Pictures by Maxine Fraumen-Prickel (Alemany Press, 1985) p.59.

Getting to know each other

(by Ann Silliman)

- When did you arrive in this country?
- How long have you studied English?
- What country are you from?
- What did you do in your country?
- What languages do you speak?
- How many different countries have you visited?
- Do you have relatives in this country?
- What are your education plans?
- Do you have a job now?
- What are your job plans for the future?
- What is your dream for the future?
- What do you like to do for fun?
- What is your favorite food?
- What is your favorite sport?
- What kind of music do you like?

Health questions

(by Fiona Armstrong)

- Do you have a family doctor?
- Is your doctor a man or a woman?
- Which do you prefer, a man or woman doctor? (Why?)
- Have you ever been hospitalized? (Where?)
- Have you ever had an operation/surgery? (Where?)
- Do you have medical insurance or Medicaid?
- How long do you usually wait when you go to the doctor?
- Do you go to a private doctor or to a hospital or clinic?
- How often do you go for a check-up?
- Have you ever called an ambulance? (Why?)
- Have you ever been to an emergency room? (Why? Where?)
- Do you ever take a painkiller (aspirin or Tylenol)? Why?
- Have you had a cold this year?
- Have you ever had acupuncture? (Chinese students)
- Do you prefer to take American medicine or medicine from your country?

Note: The questions in parentheses can be added for more advanced students or levels.

Hint: A picture story that works well with this is "Dr. Lee" on page 19 of Picture Stories by Ligon & Tannenbaum (Longman Publishing Group).



From the field:

Talking about testing. . . (a lighter look at ESL placement testing)

by Karen Curling

Karen taught ESL for 8 years at the Henrico County, Virginia, Adult Learning Center. She is now Program Services Director with the Literacy Council of Metro Richmond. We hope you enjoy her article as much as we did!

If you teach English as a Second Language, I'm sure you'll agree that placing a new student in an appropriate level can be a difficult and time-consuming task. Perhaps your program is still searching for that perfect ESL placement test. Relax! Your worries are over! The staff of the Adult Learning Center of Henrico County (Virginia) Public Schools has developed not one, but *two*, sensitive and effective screening instruments; ideal for use in any ESL program.

Our first placement test is called the DYSE TEST (pronounced "dice"). This test is especially appropriate for those programs which cannot afford the luxury of a placement counselor to handle registration and assessment. How many times has this happened to you?—you are fifteen minutes into your lesson for the evening when you happen to glance out into the hall and see 25 foreigners arriving to sign up for English classes. Your first impulse is to grab the nearest unoccupied desk and pretend you can't speak English either.

With the DYSE TEST there's no need to panic. Calmly walk to the door and ask each new student the following question: "DO YOU SPEAK ENGLISH?" If the student smiles and says nothing, you will be safe in enrolling him in the beginning class. If the student says "no," you may escort him to the intermediate level class. (Obviously the student knows quite a bit of English if he is able to tell you that he can't speak English.)

If the student responds with a "yes" to the DYSE TEST, take him immediately to the advanced class—or, better yet, sign him up to *teach* the advanced class. Any foreigner who admits to speaking English probably has a far better command of the language than most Americans.

The DYSE TEST—simple, effective, and you're back to your lesson before the blackboard has had a chance to get cold!

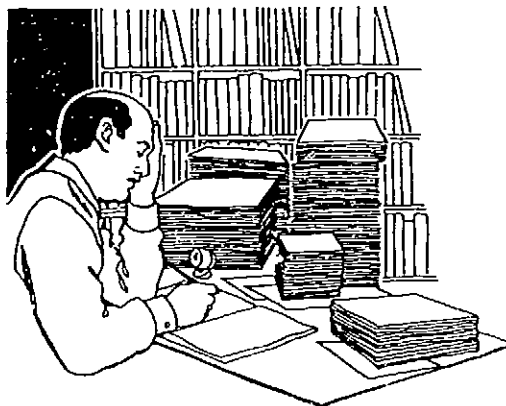

Our second assessment instrument is a bit more professional and sophisticated. It takes 117 ½ minutes (per student) to administer, but the results are well worth the effort. A composite score based on fluency in all the skill areas—listening, speaking, reading, and writing—makes it virtually impossible to misplace a student. Following are excerpts from actual case histories of students who completed this testing and received their class level assignments.

CASE 1

Me: I see by your placement forms, Ms. X, that you're to be in the advanced class which meets Monday and Wednesday evenings.

Student X: What night does Jim teach?

Me: Uh. . . Jim teaches Tuesday and Thursday nights, but that's the intermediate class. You've already been in the intermediate class for 3 years now. Don't you want to try something a little more challenging?

Student X: No, I want to be in Jim's class.

Me: Well, if you insist. . .

(I write Student X's name on Jim's roll and toss the placement form in the trash.)

. . . a lighter look, continued.

CASE 2

Me: Welcome to the USA, Mr. Y. I see you've been in the U.S. for only one week, and you'll be in the beginning class on Tuesday and Thursday.

Student Y has not understood anything I have said, but fortunately he has a friend who is translating. After a few moments of rapid exchange in the native language, the friend says that Mr. Y works on 'Tuesday and Thursday evenings and can only' come on Mondays and Wednesdays.

Me: No problem. . . I'll just sign him up for Margaret's advanced English on Mondays and Wednesdays. (That's the class that's reading *Gone With the Wind* and writing 5-page typed essays on the use of relative pronouns in subordinating clauses in the subjunctive mood.)

As I toss the placement form into the trash, I rationalize my actions by remembering that Margaret once told me she liked multi-level classes.

CASE 3

Student Z: I want to be in the class with the teacher who's a belly dancer.

Me: Oh. . . .

I toss the placement form into the trash.

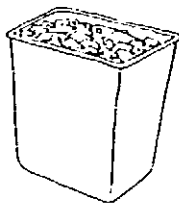

We're already working on revising our placement procedures for next year. We're going to have all the teachers line up in the hall. A student may register for a class by going and standing behind the teacher of his or her choice. We think it has possibilities.

(This article originally appeared in the Washington Area TESOL newsletter, and is reprinted here with the permission of the author.)

Hints & tips

Got an idea that works for you? Maybe you'd like to share it with other readers! ESL teachers and tutors are always looking for ideas to try out with their students.

Scrabble-crossword

Blanca Gallardo, an ESL teacher in Syracuse, N.Y., has a great way to expand a Scrabble game into a creative language activity.

She has her students play Scrabble around one theme, or topic. All the words used in the game have to relate to that topic. For example, "travel," or "crime." At the end of their Scrabble session, students copy the complete board onto a piece of paper.

Now they have, on paper, what looks like a completed crossword puzzle. The next time they meet, the students work on writing clues for the words and numbering each one. They then re-copy the grid, leaving the squares blank. The result—a crossword puzzle, made from the students' own Scrabble game!

This crossword puzzle can be photocopied and distributed for other students to solve.

Practice what you teach

A few months ago we spoke with Harvey Moore of Boulder, Colorado, about his work with some Chinese scientists there.

As part of his effort to make the students feel less self-conscious about speaking English, he asked them to teach him to speak Chinese. He also insisted that they teach him how to say their names *correctly*, rather than anglicizing them.

For a lesson on interrupting, he took the students to a shopping mall and had them approach people to ask for directions. As a follow-up to that experience, they went to an Asian center where the teacher had to ask for something in Chinese. He reports that the students laughed and laughed at his attempts.

Harvey claims to be inexperienced in ESL, but we found his ideas to be bold and inspiring. Taking the time and the effort to share in the students' learning experience is one good way to establish a comfortable learning environment.



On the market

Reviews of useful ESL materials

Seriously now. . .

Placement testing

Many ESL teachers express frustration about the testing and placement procedures available to them. If your program is in the market for a placement test, you may want to know about these:

BESTEL—Better Edition of STEL (Structured Tests of the English Language) for grammar structure.

CELSA—new edition of the ELSA (English Language Skills Assessment, in a Reading Context) for reading and grammar in context.

Unfortunately we can't review the new version of these tests for you, as we haven't used them. But we did like the older versions, for several reasons.

- They were easy to administer.
- They seemed to place students accurately.
- The range of levels was wide.
- They could also be used as achievement tests.

Both of the new tests are multiple-choice written tests, so they are for students who already have literacy skills. They each take 45 minutes to administer. A kit for the BESTEL or the CELSA costs \$60, and contains instructions, 20 reusable test booklets for two versions of the test, copyable student answer sheets and a technical manual.

We think these tests are worth looking into. For information or orders, contact:

Association of Classroom Teacher Testers
1136 Clement Street
San Francisco, CA 94118
phone: (415) 387-5779
fax: (415) 387-6061

(A Listening-Speaking test, based on the Ilyin Oral Interview, is also being developed.)

*"All About English as a Second Language—
A Basic Guide to ESL and Bilingual Education"*
by Salvatore J. Parlato, 1991.

A resource of resources

Did you know that there are nearly a thousand U.S.-based organizations that service ESL in various ways? If you want addresses and phone numbers for the professional organizations, government agencies, literacy groups, advocacy groups and other offices relating to the field, you've got it all here in one slim but impressive volume.

This professional guidebook will get you started in looking for information about the following types of questions:

Where can I get an advanced degree in ESL?

What professional organizations can I join?

What publications are available?

How can I find out about grants?

How can I contact foreign embassies?

Where is the nearest Immigration and Naturalization Service (INS) office?

How can I find out about overseas jobs in ESL?

Is there an advocacy group for my students?

Where can I get addresses of ESL publishers?

What companies make computer software or videos for ESL?

. . . and more.

By pulling together all of this information, Sal Parlato has filled a need for some unity in our scattered and diverse field. The directory is a thorough listing, efficiently presented. Be warned, though, that there is little commentary on the entries. For example, publisher names, addresses and phone numbers are listed, but not *what* they publish. You're on your own in figuring out which contacts fit your needs.

We'd love to see the book expanded to include more description—a major task indeed—but then, we're greedy for information! If you're willing to do some homework, all the sources you need to start looking for answers is right here.

Available from TESOL, 1600 Cameron St.,
Alexandria, VA 22314, USA. tel: (703) 836-0774
for \$11.50 including shipping & handling.

EDUCATIONAL SHOWCASE

Your ESL Connection

Providing ESI /EFL Programs for All Ages

The Largest Collection of ESL Materials
on Display in the Midwest

- * Place orders by mail or fax: (313) 680-1052
- * UPS delivery in 5 to 10 days of in-stock items
- * We meet publisher's prices AND beat the service
- * To order or to receive our comprehensive ESL catalog write to:



EDUCATIONAL
SHOWCASE
1334 Wheaton Street
Troy, MI 48083
(313) 680-0860

Need an idea for your teaching?
Trying to solve a teaching dilemma?
Have a question, but don't know who to ask?

Call the *Hands-on English*

Hotline



(315) 445-0785

Best time to call: 6-8 pm EST, Sun-Fri.
Or, leave a message on our machine.

Maybe we have an idea that can help.



American English Publications

10 Years of E.S.L. Service

356 Dongan Hills Avenue - New York, New York 10305
Tel. (718) 667-6637



A SPECIAL PRICE FOR A SPECIAL BOOK

MAKING IT.. A survival skills workbook that's perfect for adult immigrant students

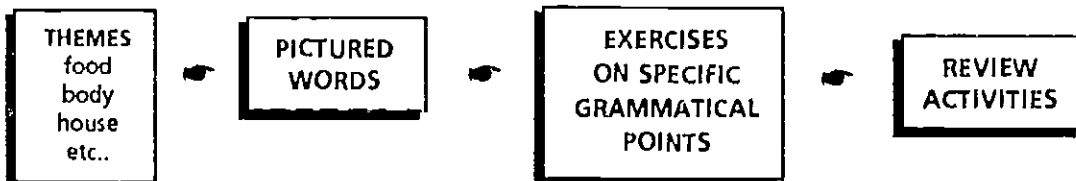

Teacher's Edil. (44 pp.)	\$3.95 \$4.95	Chart Book (14 charts)	\$3.95 \$3.95
Student's Book (108 pp.)	\$6.45 \$7.95	Flashcards (124 cards)	\$5.45 \$4.45
COMPLETESET \$24.05 \$19.95			

News & notes



Upcoming conference

◆ August 4-8, 1992—Linguistic Association of Canada and the U.S. (LACUS) at the University of Quebec, Montreal, Canada. For information, contact: Valerie Makkai, Secretary-Treasurer, LACUS, PO Box 101, Lake Bluff, IL 60044, USA.

Note: There will be more conferences of interest to ESL educators starting in October.

Mini-grants

Hands-on English received 25 applications for the 1992 Mini-grants, to be awarded later in June. Our distinguished committee is still reviewing the applications—the awardees will be announced in our next issue.

Folktales, anyone?

We're planning to present some ideas about using folktales with ESL students in a future issue of *Hands-on English*. If you've had any experience with this, drop us a line! We'll pool these ideas together.

Books received

Hands-on English has received the following books and materials:

Crossroads 2 by Shirley A. Brod and Irene Frankel (1992 Oxford University Press).

English! English English!—two workbooks with tapes by Rosana Rusque and Linda Segal (1991 English, English, English, Ontario, Canada).

Look at the U.S., Book 1 by Carole Cross (1989 Contemporary Books, Inc.).

Our Lives by Myron Berkman (1990, Linmore Publishing, Inc.).

Stories from the Heart by Ronna Magy (1991 Linmore Publishing, Inc.).

Tales from Around the World by Jeanne B. Becijos (1991 Dominic Press, Inc.).

Look in our future issues for reviews of these, and other works. ↵



A periodical for teachers and tutors of adult ESL

P.O. Box 589
Dewitt, NY 13214
USA

May/June issue

89



Hands-on English

A periodical for teachers and tutors of adult English as a second language

Dilemmas:

Avoiding stress and "burn-out"

Several readers have asked us to comment on how to avoid teacher "burn-out" and keep up enthusiasm, especially as times get harder for teachers and students. After consulting with various colleagues we have compiled some thoughts that we hope will raise understanding of this tricky problem, and suggestions that we hope will help to prevent, or ease the pain of stress and burn-out.

Dedicated teachers

Teachers sometimes get a lot of bad press nowadays, as the country wrestles with the problem of how to improve our education system. Of course, mediocre teachers do exist. But taken as a group, teachers are remarkably dedicated to what they do. In a recent study by the Carnegie Foundation for the Advancement of Teaching, for example, 96% of teachers surveyed said they spend at least some of their own money in support of their teaching activities, some spending hundreds of dollars each year.

In the same study, 69% of the teachers said they spend more than 40 hours per week on their job, with 12% reporting 60 or more hours. And 55% of teachers said they tend to subordinate all aspects of their lives to their work as a teacher.

Especially us

We have to say (modestly) that among teachers, ESL teachers are an especially dedicated group of people, selfless and altruistic in our goals. We commonly deal with the student as a whole person—not just providing language instruction but helping with cultural adjustment, personal adjustment, employment, and a multitude of social problems.

Causes of stress

Unfortunately, we are not always recognized or respected for our work. In a recent survey of ESL professionals by the TESOL organization, many of those surveyed mentioned issues of respect as among the biggest problems facing ESL teachers

today. This may be in part because the public, including other educators, tends to view learning English as easy, or as a remedial subject rather than as the sophisticated language-learning process it really is.

Lack of respect, as reflected in our low pay, poor conditions, poorly organized programs, and our own eventual self-doubt and lack of self-esteem may be at the root of teacher stress and burn-out.

Isolation

For those of us working in adult ESL programs there are some special problems that can contribute to burn-out. One of these is isolation, especially true for those teaching in scattered outreach programs who may seldom have contact with other teachers at all. In many places such teachers have few if any opportunities for professional development or for feedback on their teaching. They feel they are facing a multitude of problems on their own, with no support.

This feeling is not just imaginary. Adult level ESL programs in most places tend to be fairly unregulated—often there are no professional

...*Burn-out, continued on page 6*

Contents:

Puzzle:	
- "A Dictionary puzzle"	2
Grammar grab-bag:	
- Relative clauses with <i>who</i>	4
Conversation starters:	
- Talking about sports	5
Idea file:	
- Penpals in class	8
Hints & tips:	9
News & notes:	10
On the market:	
-Review of <i>Crossroads</i>	12

Hands-on English

Volume II, Number 2
July/August 1992

Hands-on English (ISSN 1056-2680) is published six times a year (Jan./Feb., March/April, May/June, July/Aug., Sept./Oct., Nov./Dec) by Hands-on English, P.O. Box 589, Dewitt, NY 13214 USA.

Copyright © 1992 Hands-on English

Subscription rates:

\$16 for regular subscribers,
\$10 (discounted rate) for volunteers or teacher's aides, \$22 (multi-user rate) for libraries or institutions. Single copies are \$4 each. **Postage & handling:** Canada and Mexico add \$4; outside N. America add \$10.

Permission to photocopy: This periodical is copyrighted. However, we invite teachers and tutors who have a paid subscription (or whose institution has a paid subscription) to make as many copies as they need for their own classroom use.

Please don't make copies for colleagues! We survive on the subscriptions of our readers.

Editor: Anna Silliman
(M.A., Teachers College, Columbia Univ.)

Address correspondence to the editor,
Hands-on English, P.O. Box 589, Dewitt, NY
13214 USA. Or call (315) 445-0785.

Subscribe today!

Send this form with your check or money order (U.S. funds only) to the above address.

Please send me a subscription to *Hands-on English* for one year (6 issues). I enclose:

- \$16 for a regular subscription
- \$10 discounted rate for a volunteer or aide
- \$22 multi-user rate for a library/institution
- postage/handling: Canada/Mexico add \$4.
- Countries outside N. America add \$10.

Name: _____

Address: _____

Institution: _____

Position: _____

11-2

Crossword:

A dictionary puzzle

Would you like your students to start using an English /English dictionary instead of their bilingual dictionary? Try this fun way to introduce the idea—a dictionary crossword puzzle.

This puzzle will help your students become familiar with the features of an English/English dictionary, and get them comfortable using it.

In order to solve the puzzle, students use the dictionary to find many different kinds of information including: synonyms, verb forms, parts of speech, spelling, acronyms and abbreviations. While working on the puzzle, they will also discover strategies for using the dictionary.

The puzzle is most suitable for high beginners or intermediate level students, but even advanced students can benefit if they need to polish their dictionary skills.

How to do it

Make sure each student has a dictionary. We like Longman's *Dictionary of American English for Learners of English* because it's inexpensive and very clearly written, but other dictionaries will work just as well.

Students can work independently on the puzzle, but it might be more exciting to put them in small groups, or teams, and compete to finish the puzzle first.

Why it works

Dictionary skills are important but can be pretty boring to teach. A game environment adds a spark of motivation to learning them. ←

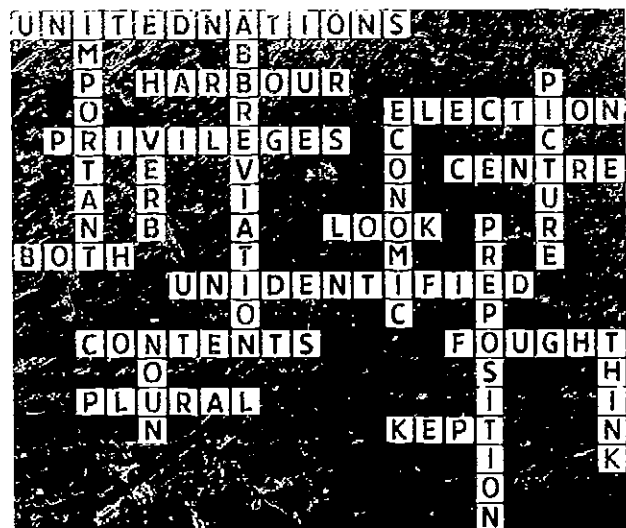

Dictionary puzzle

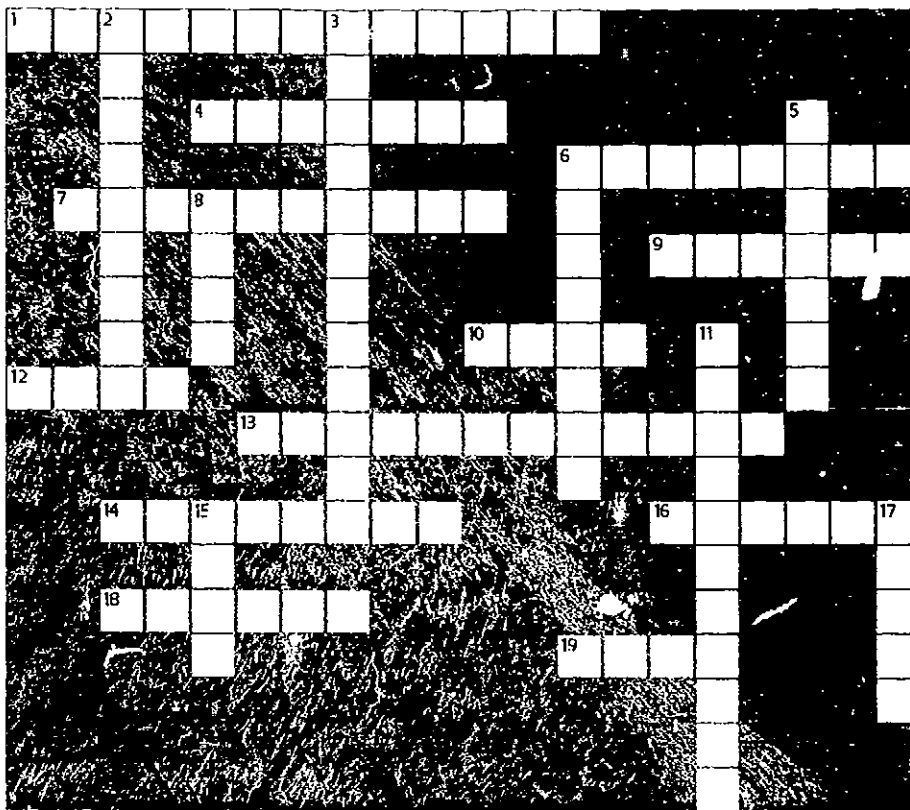

Use an English/English dictionary to find the answers to this puzzle!

Across clues

1. "UN" is the abbreviation for _____.
4. The word *harbor* in American English is spelled _____ in British English.
6. Which is the correct spelling?
elaction, election, eleccion
7. Which is the correct spelling?
privileges, priveleges, priveliges
9. The word *center* in American English is spelled _____ in British English.
10. A synonym for *glance* is _____.
12. Is the word *strike* a noun, a verb, or both?
13. "UFO" means _____ Flying Object.
14. In the front of the dictionary is a list of what's in the dictionary, with page numbers. This is called the _____.

16. What is the past tense form of *fight*?
18. "pl." is the short form for _____.
19. What is the past tense form of *keep*?

Down clues

2. "VIP" means Very _____ Person.
3. "*abbrev.*" is the short form of _____.
5. A synonym for *illustration* is _____.
6. "EEC" means European _____ Community.
8. Is *escalate* a noun, a verb, or both?
11. "*prep.*" is the short form of _____.
15. Is *scandal* a noun, a verb, or both?
17. The symbol "θ" has a sound like in:
drink, think, blink

Grammar

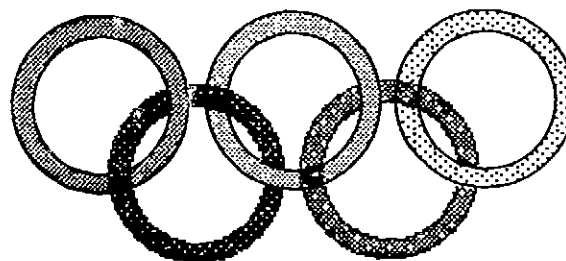

"He's the one who got the gold."
(Relative clauses with *who*)

Now that the summer Olympics are over, you can use the results to create some grammar exercises for your students. The scores provide an opportunity for some practice with relative clauses which might be appropriate for intermediate students or high beginners.

How to do it

First, look for the results for various sports events in newspapers and magazines. Choose a few events and fill in the information on the chart below. Or better yet, bring in the newspaper articles and have your students use their scanning skills to find the information themselves.

Once the chart is completed, have students sit in pairs and question each other about the athletes. One student asks, for example: "Who is Xiong Ni?" The other student looks for the name on the chart and answers: "He's the Chinese athlete who won the bronze medal in men's platform diving."

You should provide a clear example for the students to refer to—either write this on the board or on the worksheet itself.

After the students have worked in pairs for a while, you could do the exercise again with the

whole group. By this time the students should be fairly fluent in their answers.

Follow-up

This is the perfect opportunity for a role-play. One student is a reporter, the other is an athlete. The students can practice this in pairs for a few minutes and then present their role-play to the group.

For a follow-up reading activity, write down 10 or 12 sentences about the sports events on the chart, using *incorrect* information. For example, "The athlete who comes in third will win the silver medal." Have the students read the sentences together and correct them, either orally or in writing.

If this activity is a hit, you won't want to pass up the opportunity to practice 'good, better, best' using the same chart. But save this for another lesson.

Why it works

As a grammar exercise, this may seem awfully easy to us, but it gives the students the chance to get really comfortable with one complex sentence structure. The language in the exercise is appealing to them because it is sophisticated, adult and meaningful. ←

Sport	Event	Gold	Silver	Bronze
		Name/Country	Name/Country	Name/Country

Conversation starters:

Talking about sports

We've had several requests from readers for tips on conversation groups. How can you get students to join into the discussion? Here are just a few thoughts:

- It's important that you not talk too much yourself, especially at the beginning, to give students a chance to get started. It may be hard to resist talking--especially if there's silence--but try it.

- People love to talk when somebody is really interested in what they say. The more interested you are and the better you listen, the more eager students will be to join in.

- The better students know each other, the more comfortable they are conversing. A new group may take a while to develop a good relationship.

- If you have a large class, dividing up into smaller groups will help to create an atmosphere more conducive to discussion. Try making these discussion groups permanent--so that each time the class breaks up for discussion the students will be meeting with the same people.

- You can structure the conversation to get started by having an interesting question or two for each student to respond to.

Included here is a list of conversation starters, all relating to sports, which we hope will inspire you. You can select one or two questions from the list which you think will interest your group. Have fun! ➔



Personal preference

Did you watch the Olympics on TV?

Which events did you see?

Which event did you enjoy the most?

What sport do you most enjoy *watching*?

What sport do you most enjoy *playing*?

If you could win a gold medal in the Olympics, which event would you like to win? Why?

Background knowledge

In your country, do children play sports in school? If so, is it mandatory? Which sports do they have in school?

What is the most popular sport in your country?

Do women play this sport? Do children play this sport?

Explain how to play _____ (ie. soccer).

How many players are needed?

How do you get points? etc.

My doctor told me I should get more exercise.

Which sports can you advise me to try?

Why?

What does an athlete have to do to train for the Olympics?

Local information

Did you attend sports events in your country?

Have you been to a sports event here?

What sports events are available in this community?

Do you know the names of any local teams?

What sports activities are available here for people to participate in?

Sports as business

Some athletes are paid a lot of money to play.

What do you think about this?

Why do some athletes make TV commercials?

What do you think about this?

If you could change the TV coverage of the Olympics, what would you do?

International relations

Do you think the Olympic Games are a good thing? Why or why not?

Do you think the Olympics are good for international relations? Why or why not?

Are there any sports you think should be added to the Olympics? Which ones?

standards, no program guidelines, no unions, and no professional organizations that speak out strongly on behalf of teachers working with adults.

Conditions

Besides lack of support, difficult teaching conditions are a common complaint among adult ESL teachers. We would guess that multi-level classes is the number one complaint, with ongoing enrollment, class size and lack of materials (even just plain old books) coming after.

What makes all of these conditions so stressful for us is the burden of responsibility we feel toward our students—we sometimes feel that we alone are responsible for helping our adult students, and thus their children, to succeed in their new country. This is a huge burden that no one person should have to bear alone.

It is when we can no longer separate ourselves from that responsibility toward our students that we can become more and more stressed. As we find the task increasingly impossible, the final result is total loss of perspective and burn-out. Put another way, it is our commitment itself that can do us in!

Symptoms of burn-out

We talked to some teachers about what the early symptoms of burn-out might be. Here are some of the danger signals you should watch for:

- 1. Impatience with the students; irritability.** Do you feel the students are causing problems for you? They should be 'getting it,' but they're not? Do you feel angry at certain students because things don't go well? Do you find it harder to get them to cooperate?
 - 2. Anger and frustration on a daily basis.** Do you feel that nobody is helping you? That others are making it more difficult for you to do your job? Do you wake up in the morning already feeling angry?
 - 3. Less creativity.** Do you feel less willing to experiment with new things? Do you feel too tired and discouraged to read up on things that might help you in the classroom? Do you feel less interested in the students' learning process and more interested in just getting through the week?
 - 4. Low self-esteem.** Do you feel you are not doing as good a job as you could be? Do you feel you are "2nd rate?" Do you feel your students aren't getting enough out of your lessons? Do you always feel unprepared?
 - 5. Chronic health problems.** Do you feel constantly tired and dragged out? Do health problems prevent you from functioning normally for weeks at a time? Is your body trying to tell you something?
- If you are experiencing some or many of these symptoms, it does *not* mean you aren't a good teacher!

Some of the best teachers in the world (including this editor, as well as teachers this editor has great respect for) have suffered the symptoms of burn-out.

Prevention and cure

Now, to the "hands-on" part of this discussion—what can you do when you notice yourself falling into these destructive patterns? Here are a few suggestions that seem to work:

1. Find ways to break out of your isolation and gain some support from colleagues. This might include:

- Joining a professional organization.
- Attending a conference or workshop.
- Having coffee or lunch with another teacher whose enthusiasm can give you a boost.
- Starting a regular coffee hour for teachers to get together.
- Establishing contact with teachers in other places who share your interests (you could use *Hands-on English* to do this).

One teacher told us she finds workshops to be revitalizing—but they don't have to be ESL or adult workshops! She says she sometimes attends workshops for elementary teachers, because she finds them generally upbeat. Such positive contact with teachers can raise your spirits and make you feel good about your work again, even if the content differs from what you are doing.

2. Find new ways to stay in touch with your students. The closer you are to them, the more effective you will be, and the less important the conditions will seem. Ways to do this include:

- Giving your students plenty of opportunities every day to talk, and really listening to them.
- Doing some student-centered activities that take the pressure off you. You don't have to be the center of attention all the time—adult students can (and should) take a lot of responsibility for their own learning.
- If you're having a bad day, sharing that fact with the students. This will help you to see each other as real people, not just as teacher and student bringing you closer and making communication easier.

3. Make changes in your routine that will refresh you and give you new perspective. Changes might include:

- Taking a real break. Go out of town on the weekend and get a real change of scene. Take a vacation, if possible. Teachers *need* long breaks to keep going. Year-round programs are prime producers of burn-out!

Tutors, too

Although ESL tutors may not consider themselves professional teachers, they can easily suffer from exactly the same burn-out symptoms.

- Consciously changing your routine at home. Having dinner at a different time, for example—anything to keep life from becoming drudgery.
- Reversing the order of your normal lessons. If you usually do something first, do it last instead. This will keep both you and your students on your toes.

4. Find out how stress affects you personally, and do something to prevent it.

- Physical exercises. One teacher who finds that stress affects her in the throat does breathing exercises to relax. She even does some special breathing in the classroom when she feels her throat tightening up. (The Lamaze of teaching?) Also, many people say that yoga is a great way to un-stress your back and other parts of the body.
- Sleep. One teacher who had trouble sleeping on nights before morning classes found that switching to evening classes helped her to relax at night. Another teacher who couldn't sleep after teaching an evening course, found morning classes more suitable.
- Nerves in class. There are many techniques to help you feel more confident in the classroom. Don't suffer needlessly—ask other teachers for tips, or look for hints in *Hands-on English*.

If all else fails

It's possible that there is nothing else to do but leave your current situation and find something less frustrating and more rewarding to do. This is not failure—it's a chance to grow, and it's happened to many strong people.

Last spring Senator Tim Wirth of Colorado, an effective and well-liked legislator, announced to his constituents that he would not be running for reelection. Among other things, he said he was tired. "I don't have the energy to bash my head against the wall anymore," he stated. He also said, "I don't like myself when I feel angry when I start out in the morning."

If this happens to you, there are alternatives. How about teaching in a different program? How about becoming an administrator and fixing things from the top? How about starting a publication? (Warning—the name *Hands-on* is already taken!) There are many books and articles that can point you toward activities and jobs requiring the teaching skills you have.

Write to us

We would welcome any comments, anecdotes or suggestions you might have relating to this problem!

In a rut?

If you feel your teaching is in a rut, try making a small change that will surprise your students and bring a breath of fresh air to the class!

For example, reverse all the desks and teach from the back of the room. Or use colored chalk instead of white. Or wear something different than you normally would.

You'd be surprised what a big difference a small change can make!

Further reading:

The fascinating survey mentioned above of more than 20,000 U.S. teachers is published as: *A Technical Report: The Condition of Teaching, a State-by-State Analysis*, 1990 by the Carnegie Foundation for the Advancement of Teaching, Princeton University Press, New Jersey. ISBN 0-931050-39-1.

A survey of 334 ESL professionals is discussed in a brief article: "The biggest problems TESOL members see facing ESL/EFL teachers today" by James Dean Brown in *TESOL Matters*, Vol. 2, No. 2, April/May 1992, page 1.

There has been plenty of research done on the syndrome called "burn-out." Some examples of articles on the subject are:

1. *Teacher Magazine* Volume 3, Number 3, Nov/Dec 1991, pp 54-55. About coping and teacher burn-out.
2. *Teaching and Teacher Education* Volume 7, Number 2, pp 197-209. A study of the impact of variables on burn-out.
3. *Reading-Improvement* Volume 27, Number 3, Fall 1990, pp 196-199. Causes, ways to reduce burn-out and stress.

Ask your librarian to help you find further articles on this topic. ➔



Portable ideas

For those times when you may find yourself scrambling for an idea, we include another activity on a file card. You can copy this page, cut out the activity and glue or tape it to a 4x6 card.

You might want to start an **idea file**, including some of your other favorite activities as well. This way you'll have your activities at your fingertips, in case you need one on short notice.

Keep your idea file cards handy in a box on your desk, or carry them with you in a small 2-ring binder, and you'll be ready for emergencies!

Organized spontaneity

Having your lesson plan or the steps to an activity written on file cards is a big advantage in ESL teaching, by the way. With your card discreetly in your hand, you can circulate freely around the room, focus on the students and

even participate in the activity. At the same time you can feel confident that you won't forget a step or lose the flow of the exercise.

In the past we have also used file cards to provide cues for listing instructions on how to play a game, for language drills, grammar examples, and even for a story. These 4x6 file cards also fit in a 3-ring binder, so you can file them together as a unit with other teaching materials if you like.

"Penpals in class"

Here is a writing activity that is easy to set up and gives the students a wonderful opportunity to exchange ideas or communicate in a different way. Because accuracy in writing is not important for this exercise, it can also help to boost student confidence.

If the students continue to exchange letters for several sessions, an interesting follow-up activity is to ask a student to summarize orally what the correspondence has been about! ➔

Penpals in class

Purpose: Writing practice; student interaction
Level: Multi-level
Time: About a half an hour; can be repeated regularly
Materials: Some blank paper

1. Cut up a list of student names, shuffle, and have each student draw a name.
2. Ask students to write a letter to the person whose name they drew.
3. If students need help getting started, suggest that they a) tell something about themselves and b) ask two questions in the letter.
4. Give a time limit of 10 to 15 minutes for the first letter.
5. While students write, be available to help with language questions. You might also act as scribe for any low-literacy students.
6. When students finish writing, make sure they sign the letters, then hand them to the addressee.
7. The recipient reads the letter and writes an answer. Encourage students to include two questions in their response. Allow about 15 minutes for this, then ask students to send the letter back.
8. If anyone finishes early, have them start another letter to a different student.
9. Two exchanges per class period are usually enough. Continue the correspondence in a later session if students seem to enjoy it.



Hints & tips

Got an idea that works for you? Maybe you'd like to share it with other readers! ESL teachers and tutors are always looking for ideas to try out with their students.

A 'how-to' lesson

Here's an interesting way to get your students speaking in front of the group, and it works for all levels of students—even beginners.

First, the teacher demonstrates to the group how to do something, such as how to make a salad, or how to wrap a package. She describes about 5 simple steps, using words such as "first," "next" and "then" in the explanation. The students listen and perform the action at the same time.

Once students see how to give a step-by-step explanation, they can bring in something to teach to the class. Their topics should be fairly simple such as: how to make Chinese green tea, how to solve a math problem, how to make a paper flower, or anything else the students have to share.

The students will be learning from each other and having fun as they focus on the instructions each student gives.

Thanks to Marge Morchower, ABC teacher in Syracuse, NY, for relating this activity!

'How-to' follow-up

Write down the students' instructions from the above activity. Then use these student-made lessons for dictations in a later session.

For literacy students you could write each step on a separate sheet of paper and have them put the steps in order.

You could also use these pieces of paper for an oral exercise called a "strip story." (For an article on strip stories, see *Hands-on English* Vol. I, No. 1, page 2.)

The students will already be familiar with the content, making the exercises more approachable for them.

Look and see

Recently a student asked us about the difference between "look" and "see." We tried giving lots of examples to explain the difference, but finally realized we could sum it up

with a simple graphic.

look:



see:



Look (or look at, look for) is an action you perform with your eyes. See describes the impact of visual input on your mind, and can even be a synonym for understanding. (Aha! Now I see!)

Telephone technology

Telephone conversations are always difficult for beginning and intermediate ESL students. But now new technologies such as call waiting, hold, conference calls, answering machines and automated computer recordings make this an even greater obstacle!

One instructor realized how complicated the phones have become when she recently moved to a new home and had to obtain new phone services. She found getting the answers to all her questions such an ordeal that she decided to make a life skills lesson out of it for her students.

She dialed the phone company's information line for new customers several times in order to write down the message in its entirety. This included such phrases as "...if you have a touch-tone phone, please press 1," etc. She then used the message as dictation and discussion material for her students.

You can use other lengthy recordings students might encounter, such as from government, insurance company or catalog 800 numbers as well. For a great listening exercise bring in a tape recording of the message (you can record this on an answering machine with a 2-way recording feature).

Thanks to Martha J. Robertson, ESL tutor trainer at Western Wyoming Community College Adult Learning Centers, for sending us some of her ideas on teaching about telephones. ☛

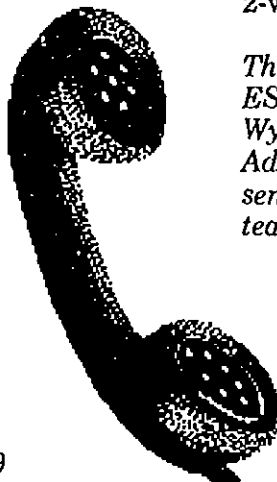



Mini-grants awarded

We're proud to announce that we awarded the first annual *Hands-on English* Mini-grants in July. Our committee of experts selected five applicants to receive a \$100. award for their teaching projects.

The awardees were:

Jane Brody of the Sterling Municipal Library, Baytown, Texas. She proposed a writing incentive program that would offer a free book for every three stories an ESL student writes. Those stories would later be published in the literacy program's quarterly publication.

Georgieann Darter of the Adult Education Center, Dermott, Arkansas. She proposed a project which will involve Spanish-speaking migrant parents reading to their children.

Susan M. Hickey of Hogar Hispano, Arlington, Virginia. Her proposal would allow basic literacy-level students to develop vocabulary lessons from their own snapshots of a field trip.

Kathleen L. Johnson of BOCES Geneseo Migrant Center, Geneseo, New York. By creating their own TV commercials, her students will develop their language skills as well as their critical thinking skills.

Barbara A. Smith-Palinkas of District 113 Continuing Education, Highland Park, Illinois. Her beginning-level students will develop their own ESL "Yearbook," with photos and stories about each student.

Hands-on English will report more details on these projects in future issues.

If you have an idea for a teaching project and would like to apply for next year's Mini-grants, call or write for an application. The deadline for applying is April 30, 1993.

A book bank

We've just heard about a great idea—the Arizona Book Bank Project, started by some teachers, takes used school books that would otherwise be thrown out by the school and gets them into the hands of people who have few books at home, at no cost.

The Book Bank Project states: "We could educate America with the school books we are now throwing away."

This non-profit project is a proto-type that could be implemented in other states. For more information call: Diana French at 1-800-642-1616.

Upcoming conferences

♦ October 2-3, 1992—Mid America TESOL (MIDTESOL) at the University of Missouri, Kansas City, MO. Contact: Phyllis Mithen, 3877 Marietta Ave., St. Paul, MN 55104. (314) 658-2319, ext. 2320.

♦ October 8-9, 1992—Southeast Regional TESOL Conference, "Lighting the Horizons," at The Mississippi Beach Resort Hotel, Biloxi, MS. Contact: Jude Lupinetti, 340 Nichols Dr., Biloxi, MS 39530. (601) 374-1922.

♦ October 22-24, 1992—Indiana TESOL. Contact: Mary Boyd, Indianapolis, IN. (317) 274-2188.

Accent not a problem

In Westfield, Massachusetts, 400 citizens had signed a petition asking to bar teachers who speak with a 'foreign accent' from 1st or 2nd grade classrooms. Fortunately the school board has rejected the proposal, which is probably not legally enforceable anyway.

Apparently the school administration plans to move two teachers from the bilingual program into regular classrooms, which set off the controversy.

We hope this anti-pluralistic attitude doesn't become a trend—an accent is not a communicable disease! If this becomes an issue in your community, please do get involved and speak out.

Books received

Hands-on English has received:

America from A to Z—an Alphabetical Introduction to the United States and the English Language by Salvatore J. Parlato (1989 American English Publications).

Hands-on folktales

In our next issue we'll talk about using folktales with ESL students. Call or write us if you have experiences to share! ☛

EDUCATIONAL SHOWCASE

Your ESL Connection

Providing ESL/EFL Programs for All Ages

The Largest Collection of ESL Materials
on Display in the Midwest

- * Place orders by mail or fax: (313) 680-1052
- * UPS delivery in 5 to 10 days of in-stock items
- * We meet publisher's prices AND beat the service
- * To order or to receive our comprehensive ESL catalog write to:



EDUCATIONAL
SHOWCASE
1334 Wheaton Street
Troy, MI 48083
(313) 680-0860

Classified ads

New! Starting next issue, *Hands-on English* will run a "classified ad" section. Here you might see notices about schools or courses offered, publications, or new products. You might also see special offers or requests from our readers.

A classified ad will cost US\$10, for 30 words or less. However, there is a DISCOUNT of 50% for current subscribers! What a deal!

If you would like to publish an ad in *Hands-on English*, send your message (include payment) to:

Hands-on English
Classified ads
P.O. Box 589
Dewitt, NY 13214
USA

Or, call the office at (315) 445-0785. ☞

News & notes

News items of general interest will still be printed in our News & notes section, at no charge, of course.



American English Publications

10 Years of E.S.L. Service

356 Dongan Hills Avenue - New York, New York 10305
Tel. (718) 667-6637

POST'EM OR COPY'EM

These 11 X 17 inch REPRODUCIBLE CHARTS
will enhance your classroom!

- Introduce new concepts
- Expand vocabulary
- Stimulate conversation
- Generate writing lessons

\$1.00 each...6 for \$5.00
40 pictures per chart
Include 9% for shipping/handling



A SPECIAL PRICE FOR A SPECIAL BOOK

MAKING IT.....
A survival skill
workbook that's
perfect for adult
immigrant students

**MAKING
IT**

See back issue of *Hands-on-English*
for details.

On the market

Reviews of useful ESL materials

"Crossroads" Book 1 and Book 2 by Irene Frankel, Cliff Meyers and Shirley A. Brod, with Earl Stevick (1991 Oxford University Press). (Books 3 & 4 are not yet in print.) Includes:

<i>Student book 1 & 2</i>	<i>\$6.95 ea.</i>
<i>Teacher's book 1 & 2</i>	<i>\$9.95 ea.</i>
<i>Cassettes 1 & 2</i>	<i>\$28.95 ea.</i>
<i>Resource package 1 & 2</i>	<i>\$49.95 ea.</i>

Readers have sometimes asked us about materials for zero level ESL students with limited literacy skills. The *Crossroads* series just may fill the bill for programs that serve such students.

Flipping through the student book, you don't at first see much difference between this and a number of other nice beginning ESL texts. There is a blend of speaking, listening, reading and writing exercises, including dialogs with real life content, illustrations of new vocabulary, and a grammar focus with practice exercises for each unit.

Beyond that, though, there are some big differences from other ESL materials:

- *Crossroads* starts out at a much lower level

12

and continues at a much slower pace than most other beginning texts.

- There is an emphasis on pair-work, with many clever information-gapping exercises for student interaction.

- For each unit there are worksheets or activities at two levels to accommodate a multi-level group.

- The resource package has photocopyable teaching materials, pictures, word cards and games to supplement each unit.

- The teacher's book is extensive and would be of great help to an inexperienced teacher in explaining techniques and suggesting further activities.

Among the things we particularly like about this series is the cast of characters, which the students can become familiar with as they progress through the units. We also really like the art work—the illustrations convey a tone of adulthood and fun. Finally, from a language-learning point of view this is one of the most comprehensive and carefully thought-out packages of ESL materials we have looked at.

If your program has classes for real beginners, you should certainly consider this series. Tutors of beginning-level students (especially literacy-level students) may also find the series useful. ☛



A periodical for teachers and tutors of adult ESL
P.O. Box 589
Dewitt, NY 13214
USA

ADDRESS CORRECTION REQUESTED

July/August issue

101



Hands-on English

A periodical for teachers and tutors of adult English as a second language

Why folktales?

Folktales for adult ESL?

If you're afraid folktales might be too silly for your students, or not relevant to adults, take a look at some of the suggestions we've got for you in this issue! You'll discover folktales can be a rich source of great language learning material.

Here are some of the reasons why:

1. They are good stories.

As stories, folktales are surprisingly delightful, suspenseful and fun! Language activities such as predicting, retelling, role-playing, discussion and interpretation work very well with folktales.

2. They are usually simple and short.

Folktales lend themselves to ESL learning because they are easily comprehensible. New vocabulary can be presented with pictures, so beginning level students can participate.

3. They are familiar to the students.

The same folktales often appear (with variations) in different cultures. Students will therefore have a starting point to understanding a new story, which gives them confidence. They can make cross-cultural comparisons with the versions they know.

4. They contain universal themes.

The content of most folktales are universal themes of love, hate, greed, anger, betrayal, honesty, loyalty, etc. These are familiar issues of interest to people from all cultures.

5. They contain adult themes.

Many folktales entail serious conflict of some kind (abandonment, murder, abuse, loss) which adults can understand from their own life experience. The folktale provides a 'safe'

structure for discussing such themes.

6. They contain repetitive language.

Folktales grew out of an oral culture, so phrases are often repeated in a formulaic way. This helps ESL students to gain confidence in the language, and makes for good pronunciation practice.

7. They are similar to each other.

When students read several folktales, they will start to see patterns in the story elements. They can compare and contrast the characters, plots and motivations in a sophisticated way, even with a fairly basic level of English.

8. They are open-ended.

Like most good literature, folktales allow for various interpretations of what happened. This gives students a chance to use their intelligence and creativity in discussing them.

Try some folktales—then write and tell us how it went! ↩

Contents:

Idea file:	
- "Folktale news reports"	2
Puzzle:	
- Multi-level puzzle on the election	4
Grammar grab-bag:	
- Present perfect with adverbs	6
Group work:	
- Reviewing children's books	7
Hints & tips	8
On the market:	
- Folktales and fables	9
Classified ads	10
News & notes	12

Hands-on English

Volume II, Number 3
September/October 1992

Hands-on English (ISSN 1056-2680) is published six times a year (Jan./Feb., March/April, May/June, July/Aug., Sept./Oct., Nov./Dec) by Hands-on English, P.O. Box 589, Dewitt, NY 13214 USA.

Copyright © 1992 Hands-on English

Subscription rates:

\$16 for regular subscribers,
\$10 (discounted rate) for volunteers or teacher's aides, \$22 (multi-user rate) for libraries or institutions. Single copies are \$4 each. **Postage & handling:** Canada and Mexico add \$4; outside N. America add \$10.

Permission to photocopy: This periodical is copyrighted. However, we invite teachers and tutors who have a paid subscription (or whose institution has a paid subscription) to make as many copies as they need for their own classroom use.

Please don't make copies for colleagues! We survive on the subscriptions of our readers.

Editor: Anna Silliman
(M.A., Teachers College, Columbia Univ.)
Consulting Editor: Karen Campbell

Address correspondence to the editor.
Hands-on English, P.O. Box 589, Dewitt, NY 13214 USA. Or call (315) 445-0785.

Subscribe today!

Send this form with your check or money order (U.S. funds only) to the above address.

Please send me a subscription to *Hands-on English* for one year (6 issues). I enclose:

- \$16 for a regular subscription
- \$10 discounted rate for a volunteer or aide
- \$22 multi-user rate for a library/institution
- _____ postage/handling: Canada/Mexico add \$4.
Countries outside N. America add \$10.

Name: _____

Address: _____

Institution: _____

Position: _____

II-3

Idea file



"Folktale news reports"

Did it ever occur to you that maybe the Wolf *didn't* kill Little Red Riding Hood's Grandmother? That maybe he was blamed unfairly for her disappearance, due to circumstantial evidence? If the Wolf had a chance to get interviewed on the evening news, what would *he* say?*

Here's a role-playing activity that gives your students a chance to explore possible explanations behind seemingly simple tales. In doing so they are applying their adult intellect, experience and imagination, in a structured context.

Folktales are perfect for this activity because, behind a simple story line there are often serious and difficult themes. For example, why did Hansel and Gretel's parents abandon them in the woods? This scenario, in our century, might have resulted in a widely publicized court case! The tale is as grim (pun intended) as many things we hear on the news today.

Choose a tale

You'll need to start with a folktale that the students are very familiar with. Spend a couple of sessions reading and talking about the story, and make sure the students are quite familiar with the plot, the vocabulary and structures.

Act it out

Next, try a simple role-play in which the students, without using notes or scripts, act out what happened in the story. To avoid stage-fright at first, divide the students into groups and have them practice in separate areas of the room. Then have each group present their role-play to the rest.

A pantomime

To increase student confidence, there are many ways to structure the role-play, and you could try these in the next class session. For example, have one group *pantomime* the story in front of the class, while another group speaks their lines from "off-stage." This is a lot of fun and will reduce everybody's embarrassment at performing.

Have students draw masks of the characters to cover the top part of their faces (leaving the mouth and chin free for clear speaking). This helps to put the actors "in character" and also reduces self-consciousness. (continued. . .)

* Jon Scieszka has written a delightful children's book with this premise, called *The True Story of the Three Little Pigs*.

Idea file, . . .continued

Or, have the actors present their roles in teams. Two Little Red Riding Hoods meet two Wolves in the woods. The students can then help each other with their lines.

Prepare an interview

Once the students have done some role-playing and have identified with one of the characters, they are ready for the next step. Select some students to act as news reporters. Tell the others that they are soon to be interviewed. Perhaps the students playing the same role could get together to discuss their story, while the reporters are planning their interviews.

The reporters should make some notes about questions they plan to ask each character. Encourage them to ask "why" questions and to try to get at what really happened. They can prepare these questions individually or as a group.

Meet the press

When they are ready, send a couple of reporters to visit each cast of characters. Have

them interview each character one at a time (for example, first Red Riding Hood, then the Wolf.)

It might help to have a "camera"—either a real video camera, a tape recorder, or a pretend camera. This will add excitement and purpose to the interview. (If students are intimidated about answering questions, put them in teams again so they can support each others' answers.)

When done interviewing, each reporter can give a "news summary" back to the class.

Follow-up

If any of the groups have made tapes of their interviews, the whole class could listen to these together. Discussion points might include the motivation of the characters, as well as how the truth can be arrived at and what is "fair" reporting.

Writing assignment

Give the students a question about the story and ask them to answer it from the point of view of *two* different characters in the story. For example, What happened in the woods? (1. the Wolf's answer, 2. Little Red Riding Hood's answer.) ↩

"Folktale news reports"

Purpose: Speaking & listening practice; Point of view

Level: Interm. to advanced; Beginners can also participate

Time: Several class sessions

Materials: A folktale; Materials for making props, if desired

Study:

1. Read a folktale and discuss.
2. Practice vocabulary and structures until the students are comfortable.
3. Have students retell the story to establish the sequence of events.

Role-play:

4. Put students in small groups and have them select roles.
5. Have students act the story out in small groups. (No notes.)
6. Have the groups present their role-play to the whole class.
7. Increase student confidence by trying variations of this.

Interviews:

8. Select some students to be reporters.
9. Have reporters prepare questions for each character.
10. Have 1 or 2 reporters meet with each group of characters; interview.
11. Have each reporter tell the class what he/she learned.

Follow-up:

12. Play back any recordings made and discuss.



Multi-level crossword puzzle: Election issues

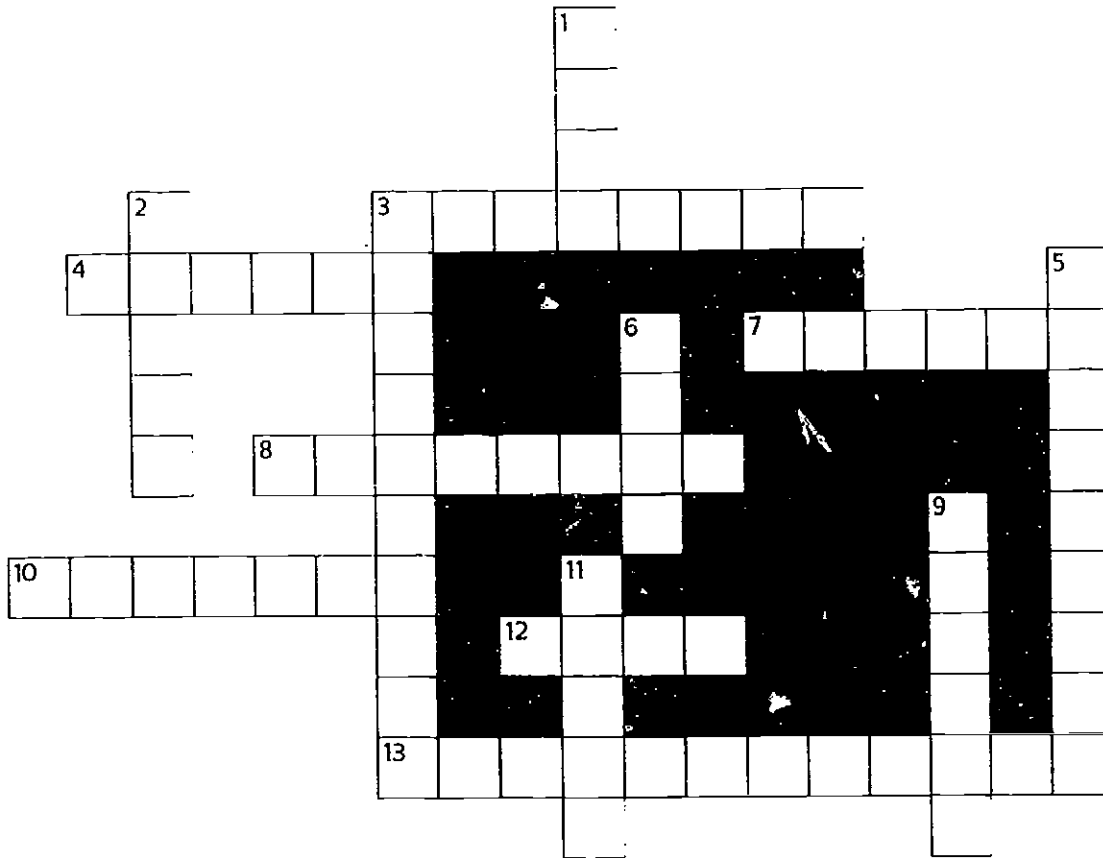

Level A

Across clues

3. A U.S. president must worry about both foreign policy and _____ policy.
4. The U.S. House of Representatives has 435 members, but the U.S. _____ has only about 100 members.
7. Most Americans want lower taxes, not _____ taxes.
8. Bush and Clinton agree that the U.S. can't afford to increase military spending. Instead, we have to _____ military spending.
10. Hillary is the name of Bill Clinton's wife, and _____ is the name of George Bush's wife.
12. The Democrats don't want Quayle for vice-president. Instead, they want _____ for vice-president.
13. Clinton's political ideas are more liberal than Bush's. Bush's political ideas are more _____ than Clinton's.

Down clues

1. Ross Perot doesn't have enough supporters to win the election, so he will probably _____ the election.
2. Abortion used to be illegal in the U.S., but now it is _____.
3. Bill Clinton doesn't belong to the Republican Party. He belongs to the _____ Party.
5. "Pro-life" supporters feel women shouldn't have abortions, but "_____ " supporters disagree.
6. Clinton is the *challenger*, because he wants to be president. _____ is the *incumbant*, because he is already president.
9. George Bush says he would like the government to help both _____ schools and private schools.
11. Many people think the U.S. economy isn't getting better. They think the economy is getting _____.

Election issues, continued

Level B

Across clues

3. Government policy on issues inside the U.S., such as housing and education, is called _____ policy.
4. The U.S. _____ has about 100 members.
7. Many people are worried that their taxes might get _____.
8. Both Clinton and Bush say the U.S. will have to _____ military spending, to save money.
10. The current First Lady's name is _____.
12. _____ is the Democrat's vice-presidential candidate.
13. In general, Republicans are more _____ than Democrats.

Down clues

1. Ross Perot will probably _____ this election.
2. Today abortion is _____ in the U.S.
3. Bill Clinton belongs to the _____ Party.
5. A person who is in favor of abortion rights is called _____.
6. _____ is the Republican candidate for president.
9. Right now, the U.S. government only pays for _____ schools.
11. Many economists say that the economy is _____ now than it was four years ago.

Word list for Level A

Barbara
Bush
conservative
decrease
Democratic
domestic
Gore
higher
legal
lose
pro-choice
public
Senate
worse

Word list for Level B

Republican/Democratic
win/lose
Bush/Clinton
Quayle/Gore
conservative/liberal
legal/illegal
better/worse
increase/decrease
foreign/domestic
Barbara/Hillary
pro-choice/pro-life
Senate/House
higher/lower
private/public

To the instructor:

Level A of this puzzle is designed to be easier than Level B. If students have trouble doing the puzzle, you can supply them with a word list (above) to make it a little easier.

You could make other vocabulary games, such as *Concentration*, from this list of "opposites."



"He's been in the news recently."
(Present perfect with adverbs of time.)

It can be really hard to convey the meaning of the present perfect to students. So we have found that it's very useful to tell students that the present perfect often (but not always) occurs with certain adverbs of time. They are signals of the present perfect.

Below are some sentences that demonstrate the present perfect with: *recently, finally, ever since, already, lately, still, yet, not yet, before, always, so far* and *after*.

Here's how to help your students discover these uses of the present perfect:

1. First, read the sentences aloud for comprehension.
2. Read them aloud again, and have students identify the present perfect verbs in each sentence. (For example, 'has been.')

3. Read the sentences again, and have students identify the adverbs of time they hear. It will help them to look at the verbs on the board as they listen. Make a list of these adverbs.
4. Hand out a copy of the text, so students can read it for themselves.
5. Have students tell something about themselves, using selected adverbs. (Example: I have recently been to a Chinese restaurant.)
6. Use a few of the sentences as a dictation (perhaps in the next class session).
7. As a writing exercise have students rewrite the sentences in the present, *omitting* the adverbs of time. (Example: Clinton has the support of many important politicians.)

Note: If these sentences become outdated, you can easily write some new ones. Choose a topic from current events that is still developing (exploration in space, medical advances, etc.). For example, "Scientists have recently discovered that..."

Examples

1. Bill Clinton has recently been in the news because he is running for president.
2. But he has been thinking about the presidency for many years.
3. Ever since Clinton was a young man, he has wanted to be in politics.
4. He has finally achieved his dream of running for the office of president.
5. He has already received the support of many important politicians.
6. His ratings in the polls have been very good lately.
7. But many Americans still haven't decided who to vote for.
8. Although Clinton is popular now, he hasn't won the election yet!
9. The race for President has not yet finished.
10. Many people believe Clinton's choice of Al Gore as vice-presidential candidate has improved his chances.
11. Senator Gore has been involved in political races before.
12. Al Gore has always been involved with politics, because his father was a Senator, too.
13. So far the race for President has been very interesting.
14. But no one will know the results until after the votes have been counted on November 3rd.

Group work: Reviewing children's books with adults

Some of our readers are working in family literacy projects, and we've had requests for family activities. Even students who don't have children might enjoy this one, though, since everybody likes to give an opinion!

Here's a discussion activity that will give your adult ESL students a chance to critique some children's books and comment on their appropriateness for children.

Choose a common folktale for this activity. (Examples might be *Little Red Riding Hood*, the *Gingerbread Man*, *Cinderella*, or any story that has a lot of versions.) Tell or read the tale several times in class so that the students are very familiar with the story.

Cultural background

Remind the students that one reason for reading this tale is that most Americans are already familiar with it, and their children will certainly hear about it at school or on TV.

Take a look

Select several versions of the *same* folktale from the children's section of the library and bring them to class. Try to choose versions that are as varied as possible. Have the students sit in small groups and pass the books from group to group so that everyone has a chance to see each one.

Tell the students that they will only have a few minutes to look at each book (so there won't be time to read them at this point). The idea is to scan the story and to guess its content from the pictures.

Talk about it

Have each group assign a secretary to record the group's responses to these questions:

1. In your opinion, what age child would most enjoy this book?
2. Is the story the same or different from the one we read in class?
3. What do you think your child would say about this book?

Compare versions

After the students have seen all the books, collect them and display them at the front of the room. Listen to each group's opinion about the books. Discuss any differences in the story which the students noticed. Then, as a class, compare the books by considering these questions:

- Which one is best for younger children? Why?
Which one is best for older children? Why?

- Which one is the scariest? Why?
Which one is funniest? Why?
Which one has the most beautiful art work?
Which one seems the most interesting? Why?

Follow-up

For a homework assignment, students could select one of the books to take home to read. If they have children at home, have them report back on the child's reaction to the book.

Take your students on a tour of the public library (or organize one for them), and make sure they know both how to get a library card and where to find the children's books.

Why it works

Children's books can actually be intimidating to parents, especially if they feel they can't understand them. By focusing discussion on the pictures in the books, and on children's reactions to them, you're putting the adult in the driver's seat.

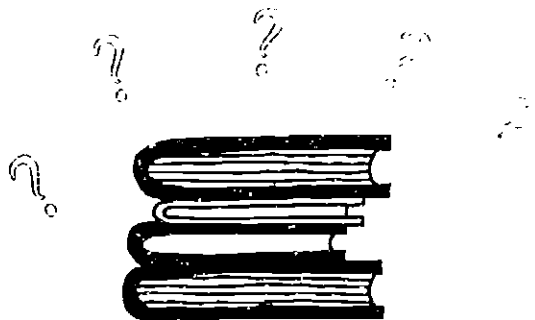

Tutors, too

The above activity can work very well with just one student.

Spread the selection of books out on the table and look at them together.

(Emphasize from the beginning that you aren't going to read the books, but rather just look at them—otherwise the student may feel intimidated.) Look through and discuss each book briefly, then compare them using the questions suggested above.

Listen while the student tells you his or her observations about the books. Ask questions that show your interest in the student's opinions. ←

Hints & tips

Have you got an idea that works for you? Why not share it with other readers? ESL teachers and tutors are always looking for ideas to try out with their students.

Sharing folktales

Have your students tell a folktale they remember from their country. Then, help the students to write these down. (Beginning or pre-literate students can dictate to you while you write; more advanced students can work on this themselves.) When the stories are written, some students may enjoy illustrating them.

The folktale 'booklets' can then be read and shared among the students.

This works well because students are really motivated to share something from their own culture with others, and will try hard to express it in English. In making a book, they are also preserving something from their heritage that they could later show their children.

Retelling a folktale

This activity is good practice for speaking and listening comprehension. Students can work in small groups, or do this as a class.

Read or tell a folktale to your students. Then, for each stage of the story, have students make a picture (a stick-figure drawing, sketch or just a symbol) to represent that part of the story. The series of pictures will help to keep the sequence of the story in mind when the students are retelling it.

Each student can tell one part of the story, according to one picture in the sequence. Or, one student can use all the pictures to tell the whole story. You can use the same pictures in a future session to review the folktale.

Thanks to June Silliman, elementary school teacher in Mount Vernon, Iowa, for suggesting this activity.

Read aloud for fun

Consider reading some of our typical folktales aloud to your class just for fun. This is a nice way to fill a little extra time, and students will appreciate learning a little more about the cultural background that Americans share.

Thanks to Karen Campbell, Syracuse, New York, for suggesting this activity.

Proverbs

Proverbs are fun to learn and talk about, and they often contain wisdom that is universal to all cultures.

Teach your students a proverb. Give lots of examples to show its meaning. Then, ask the students if they have a proverb in their language with a similar meaning. Have them write the proverb and translate it into English. This can result in a very interesting cross-cultural exchange!

"**Haste makes waste**," for example, in Polish is: "If a man does something very fast, the devil is pleased." In Hmong it would be "Hurry is poor." In Vietnamese, "If you hurry, the land puts you down."

"**Don't count your chickens before they hatch**" in Polish is: "On Friday the turkey is thinking about Sunday, but on Saturday he is killed." The Hmong say "If it's cloudy, don't think about the sun shining." The Vietnamese say "Don't talk about it until you do it."

Try this with some other proverbs, such as:

"Look before you leap."

"The grass is always greener on the other side of the fence."

"All that glitters is not gold."



For a long list of proverbs, see *The ESL Miscellany* (Pro Lingua Associates) pp.193-194.

Picture stories for conversation

Tutors working with one student or with a small group are often looking for ways to encourage speaking. 'Picture stories' are a wonderful solution to this problem!

Students can start by describing each picture, asking for any vocabulary they need. You can get them thinking about the story by making some true/false statements about the pictures. Then, the students can try to tell the story, using the pictures as a guide.

There are quite a number of books available with picture stories for beginners, and we'll review some of these in future issues. For advanced students, *Around the World: Pictures for Practice, Book 2* (1986 Longman, Inc.) has adult content, oriented toward current events. ➔

On the market

Reviews of useful ESL materials

"Tales from Around the World. Stories for Whole Language Learning" by Jeanne B. Becijos (1991 Dominie Press, Inc.) \$7.50. ISBN 1-56270-037-5.

This is a thoughtful selection of 12 folktales from many cultures (Native American, Mexican, Filipino, Argentinian, Nigerian, Vietnamese, Nicaraguan, Chinese, Russian, Japanese, Hungarian and the Southwestern U.S.) written for students with at least an intermediate level of English.

But, the book provides more than just stories. It gives you enough material and ideas to teach an entire unit around each story, integrating the geography, history, cultural background and values of each culture. If you've been wondering what the 'whole language' approach is about, this book will give you a nice taste of its benefits.

Often in adult education programs we are pulling together a hodge-podge of activities for our students—a little of this, a little of that. This can have a very disjointed effect! *Tales from Around the World* shows you how to integrate various aspects of culture and language with the study of a folktale, giving your lessons some continuity.

With the background material, language activities, ideas for writing and other projects, there is more material here than you would probably ever use with one class. This gives you a choice of activities—all in the context of a folktale—that can make learning more interesting and meaningful for your students.

One high school-level ESL teacher we know who has used *Tales from Around the World* reported it to be very workable with her students and called it a "well-crafted book" because the tales are easily compared, and show similarities across cultures as well as differences.

Although the publisher describes it as a junior high/high school text, we wouldn't hesitate to try this book with adult students. The themes of the stories (love, greed, cruelty, generosity, sorrow, hope, etc.) aren't child-like, but universal. And the cultural content of the book is certainly of interest to adults as well. ↵

"Stories We Brought With Us. Beginning Readings for ESL" by Carol Kasser and Ann Silverman (1986 Prentice-Hall) \$11.70. ISBN 0-13-850124-6.

For beginning-level students, it is often hard to find stories that are short and clear enough to understand, but that are still interesting. This collection of 21 short tales (about 150-300 words each) can fill that need very well.

These stories will be recognizable to people from many cultures. Some of them, like the Tortoise and the Hare, are from Aesop's Fables. Many convey a 'lesson' or 'moral,' while others have a humorous twist.

The simple line drawings with each story will help make the meaning clear to even the most basic student.

Each story is presented at two levels; first at an easy language level (A) and then again at a slightly more advanced, idiomatic level (B). This is a very good feature—you could use the level A version to introduce the story, then read level B. Or you could use the two levels with different students in the group.

There are some language exercises included for each story (ie. vocabulary matching, true-false, comprehension questions, sentence combining) and these are useful. However, the book lacks creative ideas for follow-up activities—you'll need to think of some yourself, or refer to *Hands-on English* for activities to expand on reading material.

Any one of the stories, including its vocabulary exercises plus a retelling activity, would provide a lesson for one session with your students. Such a lesson would also be ideal for a one-on-one tutoring session.

Because the story plots are uncomplicated, they lend themselves to retelling in the classroom. And because most of the stories are about human foibles, adults can appreciate and enjoy their content even though the language is very simple. ↵





American English Publications

10 Years of E.S.L. Service

356 Dongan Hills Avenue - New York, New York 10305

Tel. (718) 667-6637

POST'EM OR COPY'EM

These 11 X 17 inch REPRODUCIBLE CHARTS will enhance your classroom!

- Introduce new concepts
- Expand vocabulary
- Stimulate conversation
- Generate writing lessons

\$1.00 each...6 for \$5.00

40 pictures per chart

Include 9% for shipping/handling



A SPECIAL PRICE FOR A SPECIAL BOOK

MAKING IT.....

A survival skill workbook that's perfect for adult immigrant students

MAKING IT

See back issue of *Hands-on-English* for details.

Classified ads

Starting with this issue, we're running a "classified" section, giving you a chance to network with people, products & services of interest to you.

Classifieds might include notices about schools, courses offered, publications, new products, special offers or requests from our readers.

To place a classified ad, send your notice of 30 words or less with US \$10 (or if you are a subscriber, take a DISCOUNT of 50%) to:

Hands-on English

P.O. Box 589

Dewitt, NY 13214 USA

Or, call the office at 315-445-0785.

Reader request

ESL teacher of undereducated, "overaged" 17-20 year old students would like to hear from same for professional network. Write to: *Karen Campbell, 520 Pleasant St., Manlius, NY 13104-1909 USA.*

Publications

Want to spice up your tutoring sessions? Take a look at the full range of materials available from Literacy Volunteers of America.

Write/Call for a FREE 36-page catalog: *LVA, 5795 Widewaters Parkway, Syracuse, NY 13214/ (315) 445-8000.*

Story Cards: Tales of Nasreddin Hodja.

"Pick a card. Read the story. Put it down. Tell it in your words." Develop story-telling, communicative skills. 40 cards: \$13.95. *Pro Lingua Associates. (800) 366-4775.*

Back issues of *Hands-on English* are now available at US \$4 per copy (this includes shipping costs). Let us know which issues you're missing! See our address above. ➔

Advertising



Intercultural
PRESS

Your direct source for books, videotapes, and training materials on intercultural relations, cross-cultural adaptation, diversity and multicultural education.

Call or write to receive a free copy of our latest catalog.

P.O. Box 700 • Yarmouth, ME 04096
(207) 846-5168 • Fax (207) 846-5181
1-800-370-BOOK (in the U.S.)

EDUCATIONAL SHOWCASE

Your ESL Connection

Providing ESL/EFL Programs for All Ages
The Largest Collection of ESL Materials
on Display in the Midwest

- * Place orders by mail or fax: (313) 680-1052
- * UPS delivery in 5 to 10 days of in-stock items
- * We meet publisher's prices AND beat the service
- * To order or to receive our comprehensive ESL catalog write to:



EDUCATIONAL
SHOWCASE
1334 Wheaton Street
Troy, MI 48083
(313) 680-0860

Using Folktales in the ESL Classroom

A Treasury of Asian Folktales

This unique collection contains fourteen of the most well-known folktales from across Asia. The rich tapestry of folklore from countries so diverse in their cultures will give much pleasure to students as they relive the timeless adventures of deeds long past. The exquisite full-color illustrations lend mood and mystery to each of the stories.

Catalog # 00545 \$12.95

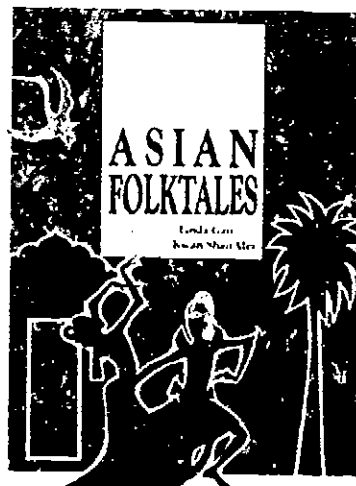

Tales from Around the World

This book brings together folktales from countries representing different areas of the world. It provides exciting and motivating reading for ESL, bilingual, junior high and high school students. Stories are presented in an "Into, Through, and Beyond" format to invite students to become involved in their literature. *Tales from Around the World* fits ESL instruction readily into a literature-based curriculum.

Catalog # 00375 \$7.50

In the Magic Corridor

In the Magic Corridor brings together myths, fables, fairy tales and legends that stir and spark the imagination. It satisfies the requirements of a literature-based, meaning-centered curriculum and integrates listening, speaking, reading, and writing through a natural and holistic approach. The tales included have been chosen from cultures around the world and are accessible to students from different backgrounds. Since their themes are universal, the tales build cross-cultural understanding.

Catalog # 00189 Student Bk \$7.50

Bridge Across the Americas

This book is a collection of traditional stories from the Americas. It motivates limited English proficient learners, who may already know the theme of these stories, to read and interact with the text. Friendly pre-reading exercises and activities that accompany the text stimulate students, lead them to deduce meaning of the vocabulary from the context, to read for heightened comprehension, and to participate in discussion.

Catalog # 00170 \$7.50

Dominie Press, Inc.
5945 Pacific Center Blvd.
Suite 505
San Diego, CA 92121
Tel: 1-800-232-4570
Fax: (619) 546-8822

News & notes



Upcoming conferences

Fall is a busy time for ESL conferences! Here is a list of the ones we know about. If you need more information about any of these, call *Hands-on* at (315) 445-0785.

10/14-17	SPEAQ - Quebec City
10/16-17	Minnesota TESOL - St. Paul
10/16-17	Washington (DC) Area TESOL
10/16-18	New York State TESOL - Rye
10/17	California TESOL - San Diego
10/22-24	Midwest Reg. TESOL - Indianapls
10/23-24	Alberta TESOL - Edmonton
10/31	Massachusetts TESOL - Waltham
10/31	PennTESOL East - West Chester
11/5-7	Rocky Mt. TESOL - Denver, CO
11/6-7	Oklahoma TESOL - Stillwater
11/6-7	TexTESOL IV - Houston
11/7	Three Rivers TESOL -Pittsbgh,PA
11/13-14	Carolina TESOL - Wrightsville Beach, NC
11/13-14	Washington Assoc for ESL-Seattle
11/14	Northern New England TESOL - Manchester

11/20-21	Puerto Rico TESOL - San Juan
11/20-23	JALT - Tokyo, Japan
11/26-28	TESL Ontario - Toronto

◆ November 5 - 7, 1992—Literacy Volunteers of America (LVA) national conference in Denver, Colorado. For information contact: LVA, 5795 Widewaters Pkwy, Syracuse, NY 13214 USA. Tel. (315) 445-8000.

Concerned about learning disabilities? The Learning Disabilities Association of America has a big conference next February which includes sessions on adult literacy and cultural diversity (second-language learners):

◆ February 24-27, 1993—LDA International Conference in San Francisco, CA. For information contact: LDA, 4156 Library Road, Pittsburgh, PA 15234 USA. Tel. (412) 341-1515.

Mini-grants applications available

Applications for the 1993 *Hands-on English* Mini-grants are now available upon request. ↗



A periodical for teachers and tutors of adult ESL
P.O. Box 589
Dewitt, NY 13214
USA

ADDRESS CORRECTION REQUESTED

September/October issue

113



Hands-on English

A periodical for teachers and tutors of adult English as a second language

Dilemma:

“Please speak English!”

What do you do if your students constantly speak their own language with each other during the ESL class? Several people have asked us about this, and we have also had this problem a number of times in the past. The reason for this problem may be a misunderstanding about how we should learn.

In one class, for example, several Polish students sat together and talked away in Polish during class, oblivious to their teacher's growing irritation. The American teacher frequently reminded them to “speak English please!” but to no effect.

Upon careful reflection, it became clear that the students and the teacher were working at cross-purposes. The Polish students were very concerned about getting everything *right* (perhaps because of their own educational background), and felt it was important to help each other by explaining or translating everything that was going on.

The teacher, however, was less concerned about mistakes. She wanted the students to enter into the spirit of the class and risk trying out their English. Also, she was accustomed to students trying to learn on their own, without ‘help’ from other students. The teacher was frustrated because the students didn't seem to care about what she wanted them to do—but of course the opposite was true!

Finally, the teacher realized that to get the students ‘on her side,’ she had to communicate explicitly to them what was expected in the classroom. So, she wrote the students a polite letter. The letter described clearly what she wanted from her students, and why:

“Dear Students, I want you to speak only English while you are in this class. This is very important for you. (1) You will learn English faster if you practice English in class. (2) It's hard work to learn English. If you try to listen, speak and think in English while you are in class your English will improve. (3) If you don't understand something, it's my job to make it clear to you, so please ask me to explain again. Or, another student can explain something to you in English. (4) Also, remember that speaking your language is not very polite to the other students in the class because they can't understand you. Thank you. Sincerely, Your Teacher.”

This formal, written letter did more to change classroom behavior than all the verbal demands the teacher had made—after the students read and discussed the letter, they changed over completely to using English during class!

Perhaps the students enjoyed being invited to participate in their own learning process. ➤

Contents

Crossword puzzle:	
- World news geography	2
Cultural information:	
- Cooking measurements	4
Cultural activity:	
- Making a pumpkin pie	5
Group work:	
- A friendly interview	8
Editorial:	
- The loneliness of an ESL instructor	9
Hints & tips	10
Classified ads	10
News & notes	12

Hands-on English

Volume II, Number 4
November/December 1992

Hands-on English (ISSN 1056-2680) is published six times a year (Jan./Feb., March/April, May/June, July/Aug., Sept./Oct., Nov./Dec) by Hands-on English. P.O. Box 589, Dewitt, NY 13214 USA.

Copyright © 1992 Hands-on English

Subscription rates:

\$16 for regular subscribers,
\$10 (discounted rate) for volunteers or teacher's aides, \$22 (multi-user rate) for libraries or institutions. Single copies are \$4 each. **Postage & handling:** Canada and Mexico add \$4; outside N. America add \$10.

Permission to photocopy: This periodical is copyrighted. However, we invite teachers and tutors who have a paid subscription (or whose institution has a paid subscription) to make as many copies as they need for their own classroom use.

Please don't make copies for colleagues! We survive on the subscriptions of our readers.

Editor: Anna Silliman
(M.A., Teachers College, Columbia Univ.)
Consulting Editor: Karen Campbell

Address correspondence to the editor.
Hands-on English, P.O. Box 589, Dewitt, NY 13214 USA. Or call (315) 445-0785.

Subscribe today!

Send this form with your check or money order (U.S. funds only) to the above address.

Please send me a subscription to *Hands-on English* for one year (6 issues). I enclose:

- \$16 for a regular subscription
- \$10 discounted rate for a volunteer or aide
- \$22 multi-user rate for a library/institution
- postage/handling: Canada/Mexico add \$4.
- Countries outside N. America add \$10.

Name: _____

Address: _____

Institution: _____

Position: _____

II-4

Crossword puzzle:

World news geography

Here's a crossword puzzle about current events that's intended to get your students working with a map. All of the answers can be found by studying a map.

Make sure you have a good world map or an atlas available for this activity. If you have many students, make sure there are enough maps so that each student can see one clearly.

Students can do the puzzle individually, or in pairs (which might be more fun).

Follow-up

This puzzle covers only three topics: Somalia, the former Yugoslavia and parts of the former Soviet Union. If your students are interested, you might want to bring in a news story on one of these topics to read and discuss together.

Have your students create their own geography questions. They could work together in small groups, with each group choosing one news topic. Looking at the map, they can write questions for the other students in the class to answer. Topics might include: The changeover of power in Hong Kong, political problems in Cambodia, the European Community (EC), coup attempt in Venezuela, etc.

Why it works

Carefully focussing on geography is one way to help students get a grasp on what's going on in the news. Because the information is visual and concrete, everyone can participate, regardless of background, and can gain confidence as a result. The topics are adult and may relate to the students' own experiences. ←

Key to puzzle:

E | S | I | O | N | I | A
 S | T | W
 N | O | R | T | H | O | E | A | S | T
 U | T | U
 H | M | O | G | A | D | I | S | H | U
 T | P | T | K
 F | I | N | L | A | N | D | R | R | B
 T | A | I | N | O
 A | S | E | V | E | N
 S | E | R | B | I | A
 A

Crossword puzzle: World news

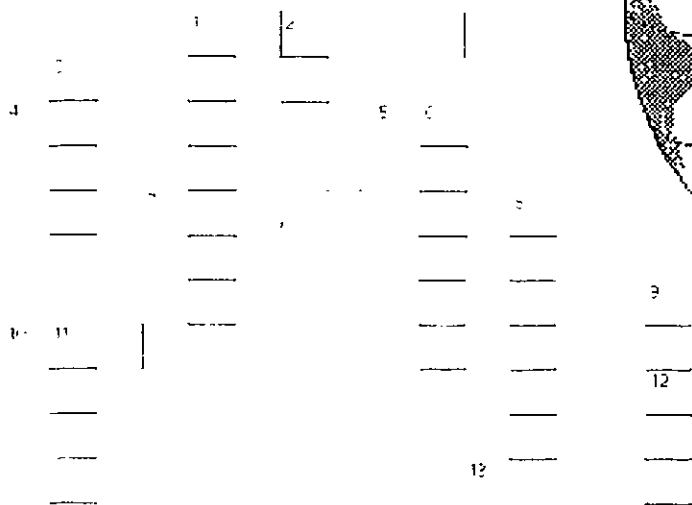
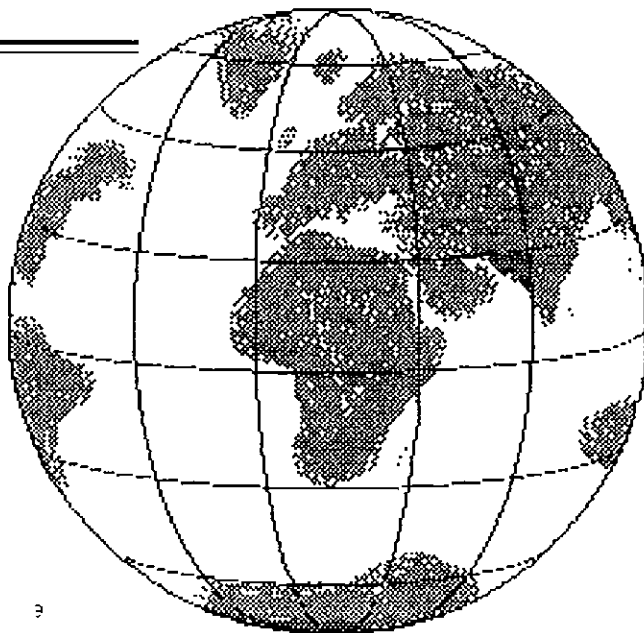

Use a map to find the answers to this puzzle.

Across clues

1. There are three Baltic states that used to belong to the Soviet Union. They are: Lithuania, Latvia and _____.
4. Chernobyl was the site of a nuclear disaster in 1986. It is located only about 60 kilometers _____ of the city of Kiev.
5. There has been a lot of fighting and starvation in Somalia. Somalia is on the _____ coast of Africa.
7. The capital city of Somalia is _____.
10. The Scandinavian country of _____ is directly north of Estonia.
12. There are _____ European countries that border on the former country of Yugoslavia.
13. The city of Belgrade is located in the new state of _____.

Down clues

1. Two countries that border Somalia on the west are Kenya and _____.
2. Somalia is bordered by ocean on _____ sides.
3. In the 1970's, Somalia was an important military base for the U.S. That is because Somalia is located directly _____ of the Middle East.
6. If refugees from the former country of Yugoslavia go north, they will come to _____ or Hungary.
8. Kiev is an important city south of Moscow. It is part of the new state called _____.
9. There is a lot of fighting in the city of Sarajevo, which is in _____.
11. If refugees from the former Yugoslavia go west, the first country they will come to is _____.

Cultural information:

Cooking measurements

Here's some information you can share with your students about the measurements we use in recipes and on food containers.

Most of the world is much more sensible and uses the metric system for this purpose. Since our students can probably manage perfectly well without it, why teach our system?—Because knowing how to use our measurement system

will allow foreigners to participate in, and enjoy, one of the nicest aspects of their new culture—the food and cooking.

Give your students a copy of this chart to keep. Folded in thirds, it will fit in a wallet or pocket for easy reference.

To familiarize the students with the chart, try some of the word problems below. ➔

Liquid measurements						Dry measurements (weight)					
liters	gallons	quarts	pints	cups	ounces	table- spoons	tea- spoons	kilos	ounces	pounds	tons
5 ml.							1 tsp.	28 g	1 oz.		
15 ml.						1 Tbsp. = 3 tsp.		.22 kg	8 oz. = 1/2 lb.		
30 ml.					1 oz. =	2 Tbsp.		.45 kg	16 oz. = 1 lb.		
60 ml.				1/4 c. =	2 oz. =	4 Tbsp.		.90 kg	32 oz. = 2 lb.		
120 ml.				1/2 c. =	4 oz. =	8 Tbsp.		2.25 kg	80 oz. = 5 lb.		
.24 l.			1/2 pt. =	1 c. =	8 oz.			900 kg		2000 lb. = 1 ton	
.47 l.		1/2 qt. =	1 pt. =	2 c. =	16 oz.			kilos	ounces	pounds	tons
.95 l.		1 qt. =	2 pt. =	4 c. =	32 oz.						
1.9 l.	1/2 gal. =	2 qt. =	4 pt. =	8 c. =	64 oz.						
3.8 l.	1 gal. =	4 qt. =	8 pt. =	16 c. =	128 oz.						
liters	gallons	quarts	pints	cups	ounces	table- spoons	tea- spoons				

(For amounts of milk, juice, soda, water, liquid soap, etc.)

(For weight of meat, beans, rice, laundry powder, etc.)

Word problems

- How many cups are there in a pint? a quart? a gallon?
- Which is more—a pint or a quart? an ounce or a tablespoon? a cup or a quart? a tablespoon or a teaspoon?
- Name some items you can buy in a gallon size. What can you buy in a quart size? What can you buy in a pint size?
- I was making some soup last night. The box said: "Boil one quart of water." How many cups of water did I need?
- If I buy 2 pints of ice cream, how many ounces do I have?
- I need one gallon of milk. How many quarts should I buy?
- The baby drank 12 ounces of juice. How many cups is that?
- I want to buy the cheapest laundry soap. Two bottles have the same price, but one says 32 ounces, the other says 1 1/2 quarts. Which one should I buy?
- I want to buy the cheapest soda. Two bottles have the same price, but one says "1 liter," the other says "one quart." Which one should I buy?
- To bake a cake I need a 2-quart pan. I have a pan, but I don't know if it's 2 quarts. How can I find out?
- I am making fruit punch for a party. The recipe calls for 4 cups lemonade, 4 cups orange juice, 4 cups grape juice, and 1 bottle mineral water (28 ounces). How big should the punch-bowl be?
- My 6 kids really love ice cream. We have ice cream 3 times a week! If I give each child about one-half cup of ice cream every time, how much ice cream should I buy for the week?

Cultural activity:

Making a pumpkin pie

Holiday season brings an opportunity to share some of our favorite traditions with our students. Pumpkin pie is great for this purpose because it is really different from any dessert served in other countries and originates historically in North America. And although students are likely to encounter this popular pie anywhere they go, at any time of year, it's nice for them to understand the sentimental connection we have to pumpkin pie for fall and winter special occasions.

There are two ways to use this material. For a "quickie" lesson, you can read and discuss the recipe on page 6 with your students. For a more involved, student-centered lesson, you can do a group activity with the material.

A "quickie" lesson

This is a pleasant activity that will work with a class, a small group, or an individual student in a tutoring situation.

First, you might want to go over the measurements used in cooking (see page 4). Do some of the word problems orally to help familiarize the students with the terms.

Next, distribute copies of the recipe (on page 6) and read through it with the students, showing them any unfamiliar ingredients and utensils (which you bring from home).

For discussion, ask if they can describe any similar dishes popular in their own culture. You might also have a chance to discuss sayings such as "Easy as pie," and "American as apple pie."

Variation

You can make the above lesson much more interesting by distributing the *blank* copy of the recipe shown on page 6 instead of the completed one. As you talk about making a pie, the students will listen and take notes in order to get the recipe.

A group activity

For a more extended lesson, you can get your students to teach each other the various steps involved in making a pumpkin pie. This kind of activity is sometimes called a "jigsaw" activity because each group of students has one piece of the puzzle. To get the completed instructions, they have to listen to the other groups and put it all together. Here's how:

1. Again, start by going over the measurements chart on page 4. Show them some measuring cups and spoons, and carefully work through the word problems together.
2. Divide the students into 6 groups, and give each group an activity card with instructions on it (see page 7).
3. Have the students study the instructions on the card with their group, providing them with help when needed. (If you can find some pictures in a cookbook that help to clarify the steps, such as rolling out the pastry, you might supply the students with these as well.)
4. Give each group a bag containing the items they will need to demonstrate their step (these items are listed on page 7), and give them some time to look the stuff over.
5. Bring the class together and hand out a *blank* copy of the recipe to each student (page 6).
6. One by one, have each group present the instructions for their step, while the other students take notes, until the entire recipe is assembled on paper. Allow plenty of time for this, as the students will ask for a lot of repetition.
7. ***For the ultimate in classroom fun, have each group present the instructions again, but this time *actually making the pie*. You probably won't want to bake and eat it, for hygienic as well as logistical reasons, but it's worth doing it anyway.

Now *that's* "hands-on!"



Why it works

People from other countries are often very interested in how we do things at home, but don't get many opportunities to find out. This behind-the-scenes look at pie-making can lead to a lot of questions about our way of doing things, as well as an interesting cultural exchange.

Getting the students to teach each other the steps involved is wonderful practice for speaking and listening, as well as a good way for them to build confidence. ➡

Pumpkin pie — a traditional treat!

Make the crust.

Make the filling.

Bake the pie.

Eat the pie.

Pumpkin pie — a traditional treat!

Make the crust.

Mix together: 1 cup flour
1/2 teaspoon salt
1/3 cup shortening (or margarine)
3 Tablespoons cold water

Roll out the crust and put it in a 9-inch pie-pan.

Make the filling.

Mix together: 1 can of pumpkin (16 ounce size)	Add: 1 teaspoon ground cinnamon
1 can of evaporated milk (12 ounces)	1/2 teaspoon ground ginger
2 eggs	1/4 teaspoon ground cloves
1/4 cup white sugar	1/4 teaspoon ground nutmeg
1/4 cup brown sugar	1 teaspoon vanilla (optional)

Pour the filling into the pie-pan.

Bake the pie. Bake at 425°F for 15 minutes. Then turn the oven down to 350°F and bake 45 minutes more.

Eat the pie. After it cools, it's ready to eat. You can put whipped cream on top, if you want to.

Making a pumpkin pie, continued.

1. To make the pie-crust:

Put 1 cup of flour in a bowl and add a half teaspoon salt. Then mix in one-third cup of shortening (or margarine). You can use two forks or a pastry cutter. Then add 3 Tablespoons cold water and mix the dough. **Advice:** Don't mix the pastry too much and it will taste better.

2. To prepare the pie-crust:

Take the pastry dough in your hands and make a ball. Put a little flour on the table and roll out the dough in a circle. You can use a rolling pin or a bottle to roll the dough. Make the circle bigger than the pan.

Carefully fold the pastry and put it in the pan. Push up the edge of the pastry with your fingers.

Advice: Keep the pastry cold by putting it in the refrigerator or freezer.

3. To make the filling:

In a big bowl, mix one can of pumpkin (16 ounce size), 1 can of evaporated milk (12 ounce size), 2 eggs, one-quarter cup white sugar, and one-quarter cup brown sugar.

Advice: It's easier if you mix the eggs before you add them.

4. To complete the filling:

Add the spices and mix them in. 1 teaspoon ground cinnamon, 1/2 teaspoon ground ginger, 1/4 teaspoon ground cloves and 1/4 teaspoon ground nutmeg and 1 teaspoon vanilla. Pour the filling into the pan.

Advice: Be careful.

5. To bake the pie:

Heat the oven to 425° first. Bake the pie at 425°F for 15 minutes. Then turn the oven down to 350° and bake for 45 minutes more.

Advice: The pie is finished when a knife comes out clean.

6. To eat the pie:

Let the pie cool first, then cut it with a sharp knife. You can put whipped cream on top if you want to. Or, some people like to put ice cream on their pie.

Activity cards

To do this activity in class, each group will need the following items:

Step 1. Bowl, measuring spoons, measuring cups, two forks (or pastry cutter) flour, salt and Crisco.

Step 2. Pie pan, rolling pin (or bottle with straight sides) spatula, extra flour.

Step 3. Bowl, stirring spoon, can of pumpkin, can of evaporated milk, white sugar, brown sugar, salt.

Step 4. Measuring spoons, ground cinnamon, ginger, nutmeg, cloves, bottle of vanilla.

Step 5. Table knife.

Step 6. Eggbeater (or electric mixer), small bowl, heavy cream. Knife to cut pie.

Group work: A friendly interview



Here's a conversation activity that will help generate a friendly atmosphere among your students. It's especially good for students who are already familiar with each other from being in the same class, but who don't really know each other very well yet.

Any level of student can participate, and the interview works fine with multi-level groups.

Customizing it

Before copying the interview sheet, you might want to adapt it to your students by adding a question or two that you know they are interested in. To add some questions, cut the sheet across the middle, separate the two halves and glue them down on a blank sheet of paper. Write your questions in the blank space between, then connect the lines with a ruler. Your customized worksheet is ready to go!

How to do it

Make sure the students know the meaning of *favorite*, and any other vocabulary on the interview sheet.

Tell the students they will have a chance to interview three people, and pair them up for

the first interview. When these students finish interviewing each other, have them switch partners.

Allow plenty of time for this activity, as it works best in a relaxed atmosphere. If the students get carried away chatting with each other, that's O.K.—after all, this is conversation practice!

Follow-up

Have each student report to the whole class what he or she learned about another student. This is good speaking practice and reinforces what was practiced before in pairs.

An alternative activity is to have each student tell what he or she has in common with the others. For example, "I found out that Maria and I have the same birthday."

Variation

These interview questions would also work very well for a "One-question interview." See *Hands-on English*, Volume II, Number 1 (May/June 1992), page 6 for instructions on how to do this. ↵

Getting to know you	#1	#2	#3
What's your first name?			
What time do you get up in the morning? Why?			
When is your birthday?			
What is your favorite color?			
What is your favorite food?			
What is your favorite kind of music?			
What do you like to do for fun?			
If you could take a trip, where would you go? Why?			

Editorial:

The loneliness of an ESL instructor. . .

We adult ESL people are so isolated! Many of our programs are small compared to the other 'mainstream' programs going on around us. Adult ESL teachers often teach part-time, and thus don't have opportunities to meet or connect with other instructors. Tutors of ESL in literacy programs are usually in the minority as well, and they have even fewer opportunities to meet each other.

Drawbacks of isolation

While in some ways it can be very nice to be off on your own, doing your own thing without being bothered, the disadvantages of isolation probably outweigh the benefits. Without colleagues, where do you get encouragement? New ideas? Incentive to try new things? Inspiration? How do you know whether you're on the right track? Most of all, who can you talk to about your experiences? On your own, you're likely to spend your time reinventing the wheel, or feeling inadequate to the huge task in front of you.

And yet, there are thousands of us, scattered all across the United States and Canada (not to mention overseas), all doing more or less the same work—helping our adult students to learn real-life English—with very similar kinds of students.

"Oh? What's ESL?"

Our isolation, though, is not only isolation from each other and from other educators. Within the larger society, we can sometimes feel that what we are doing is not understood, or even that it is unpopular. The differences that we celebrate in our students are sometimes looked down upon or even feared by the general public. The tremendous achievement of mastering English (or helping someone to master it) is often not appreciated by people who have never learned another language or lived in another country.

Because of this lack of understanding, an ESL instructor often feels like an educator for both groups—we are educating the immigrants about the rest of society, and then sometimes educating the rest of society about its immigrants. This is an important and exciting role, but it sure is lonely.

Your network of friends

As you read this, people much like you with similar problems and concerns are reading this too. One of the reasons we are so excited about *Hands-on English* is that we feel it connects all of us who are working with adult students. The goal of *Hands-on English* is not just to provide you with useful materials for your teaching (although this is very important), but also to put you in contact with a friendly and supportive network of people who have mutual goals. For this reason we encourage everybody to call or write with problems or suggestions, so we can pass them along.

"We" is me

By the way, the editorial "we" in this publication actually refers to **one** person—the editor, an ESL teacher for many years who is now working on *Hands-on English* full-time out of her home. She needs your help for two things—to spread the word to colleagues and friends about *Hands-on English*, and to share your thoughts and ideas about teaching ESL with the rest of us!

The phone number is (315) 445-0785, and the address is P.O. Box 589, Dewitt, NY 13214, USA. Can't wait to hear from you. ✉

Anna Silliman, Editor

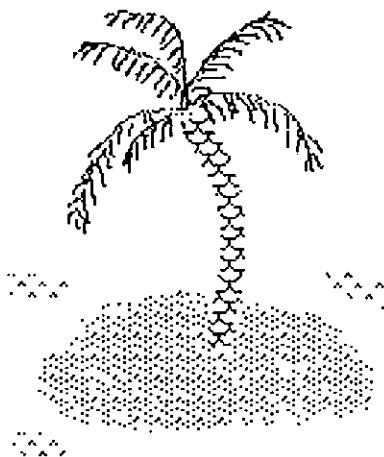

Hints & tips

Have you got an idea that works for you? Why not share it with other readers? ESL teachers and tutors are always looking for ideas to try out with their students.

Party games

If you're looking for party games for your class, don't forget some old standards that work well with ESL students. For example:

Twenty questions—One person thinks of a word, and the others ask yes/no questions until they figure out what the word is (ie., Is it something to eat?) With ESL students we like to give them a card with a word already on it. Some suggestions are: Christmas tree, cookies, pumpkin pie, television, VCR, shopping mall, supermarket, etc. You could also include vocabulary items you've recently studied in class.

Pictionary: Pictionary is a commercially available game that has been popular for several years. Played in teams, it is good for a party atmosphere and works with all levels.

Hargman: We find the original version of this game a little gruesome, so we prefer to have a man walking toward the edge of a cliff; each wrong guess brings him one step closer to falling off the cliff (where a shark waits in the water below). To play the game, a student thinks of a word and draws blank spaces on the board for each letter in the word. The other students call out letters until the word is guessed correctly (or the man goes over the edge of the cliff).

Who am I?—Pin a card with the name of a famous person on the back of each student (but don't let them see the name). The students can then circulate around the the room, asking questions of the other students until they find out their identity. Answers can only be "yes" or "no." Examples of questions: Am I alive? Am I an American? Am I famous? Am I a woman?

This game is fun to do while serving refreshments, 'cocktail party'-style. It's also funny, and a self-esteem booster if you choose the right V.I.P. name for each student. ☛

Classified ads

Your ad goes here

Our "classified" section gives you a chance to network with people and find out about products & services of interest to you.

Classifieds can include notices about schools, courses offered, publications, new products, special offers or requests from our readers.

To place a classified ad, send your notice of 30 words or less with US \$10 (or if you are a subscriber, take a DISCOUNT of 50%) to:

Hands-on English

P.O. Box 589

Dewitt, NY 13214 USA

Or, call the office at 315-445-0785.

Reader request

ESL teacher of undereducated, "overaged" 17-20 year old students would like to hear from same for professional network. Write to: *Karen Campbell, 520 Pleasant St., Manlius, NY 13104-1909 USA.*

Publications

Literacy Volunteers of America's "**I Speak English**" brings years of proven ESL techniques to ESL tutors. Includes step-by-step instruction in teaching survival skills, identifying student goals, and using reading and writing to reinforce speaking. To order or receive a free catalog, call or write: *LVA, 5795 Widewaters Parkway, Syracuse, NY 13214 / (315) 445-8000.*

American Holidays. Exploring Traditions, Customs, and Backgrounds. 17 readings each with 5 - 6 varied vocabulary exercises. Plus holiday readings, songs, national holidays of all other nations. \$9.50. *Pro Lingua Associates. (800) 366-4775.*

Back issues of *Hands-on English* are now available at US \$4 per copy (this includes shipping costs). Let us know which issues you're missing! See our address above. ☛



Intercultural PRESS

Your direct source for books, videotapes, and training materials on intercultural relations, cross-cultural adaptation, diversity and multicultural education.

Call or write to receive a free copy of our latest catalog.

P.O. Box 700 • Yarmouth, ME 04096
(207) 846-5168 • Fax (207) 846-5181
1-800-370-BOOK (in the U.S.)

EDUCATIONAL SHOWCASE

Your ESL Connection

Providing ESL/EFL Programs for All Ages

The Largest Collection of ESL Materials
on Display in the Midwest

- * Place orders by mail or fax: (313) 680-1052
- * UPS delivery in 5 to 10 days of in-stock items
- * We meet publisher's prices AND beat the service
- * To order or to receive our comprehensive ESL catalog write to:



EDUCATIONAL
SHOWCASE
1334 Wheaton Street
Troy, MI 48083
(313) 680-0860



American English Publications

10 Years of E.S.L. Service

356 Dongan Hills Avenue - New York, New York 10305

Tel. (718) 667-6637

POST'EM OR COPY'EM

These 11 X 17 inch REPRODUCIBLE CHARTS will enhance your classroom!

- Introduce new concepts
- Expand vocabulary
- Stimulate conversation
- Generate writing lessons

\$1.00 each...6 for \$5.00

40 pictures per chart
Include 9% for shipping/handling



A SPECIAL PRICE FOR A
SPECIAL BOOK

MAKING IT....

A survival skill
workbook that's
perfect for adult
immigrant students

MAKING
IT

See back issue of *Hands-on English*
for details.

News & notes

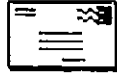

Upcoming conferences

If you need more information about any of these conferences, call *Hands-on* at (315) 445-0785.

- ◆ February 11-14, 1993—National Association for Multicultural Education (NAME), annual conference in Los Angeles, California.
- ◆ February 13, 1993—Hawaii Council of Teachers of English in Honolulu, Hawaii.
- ◆ February 24-26, 1993—Georgia's 4th Annual Literacy Conference, Atlanta, Georgia.
- ◆ February 24-27, 1993—Learning Disabilities Association, International Conference in San Francisco, CA. For information contact: LDA, 4156 Library Road, Pittsburgh, PA 15234 USA. Tel. (412) 341-1515.
- ◆ February 24-27, 1993—National Association of Bilingual Education (NABE), annual conference in Houston, TX.
- ◆ March 18-20, 1993—BC TEAL in Victoria, British Columbia, Canada.
- ◆ March 25-26, 1993—Louisiana TESOL, in New Orleans, Louisiana.

Asian schools

Why do children in Asian schools excel at a higher level than children in American schools? A new study published in the *Scientific American* points out some very interesting differences between U.S. and Asian schools. Asian teachers have more time to spend with their students and with fellow teachers. They also plan more variety and 'hands-on' activities in each lesson to keep the children's attention. Asian children have more fun in school. And, a society-wide belief that all children can learn may also be a factor.

See "Learning from Asian Schools," *Scientific American*, December 1992, pp. 70 - 76.

Mini-grants applications available

Applications for the 1993 *Hands-on English* Mini-grants are now available upon request. ↵



A periodical for teachers and tutors of adult ESL

P.O. Box 589
Dewitt, NY 13214
USA

ADDRESS CORRECTION REQUESTED

November/December issue



Hands-on English



A periodical for teachers and tutors of adult English as a second language

On the market

Reviews of useful ESL materials

"A Picture is Worth 1000 Words" by Anthony Mollica (1992, éditions SOLEIL publishing, inc.). \$24.95. ISBN 0-921831-08-0.

Teacher's Guide by Mollica, Ashcroft and Finger, no cost. ISBN 0-921831-11-0.

If you are looking for ways to stimulate conversation among your students, we have some advice—buy this book. No, we aren't on the publisher's payroll; neither are we in cahoots with the authors. We just recognize useful teaching material when we see it!

The book has 60 human interest-type photos such as you might see in a newspaper. Each photo comes in two sizes; one large enough to display to a group for discussion, and one small on a page with plenty of white space around it for writing assignments. The pictures photocopy well, and by buying the book you are granted reproduction rights for your own classes (the same policy that *Hands-on English* has).

The content of the photos is generally humorous or intriguing. They include some nice inter-generational shots such as a child telling his grandfather a story, and some cultural events such as carving a pumpkin. Many of the pictures lend themselves to discussion of what came before and after.

The teacher's guide (which is included in the price of the book—a plus) has a number of good suggestions for using the photos, as well as about 10 questions for each picture to help guide a conversation or stimulate thinking.

Whether you are a tutor or teacher, new or experienced, have beginning or advanced students, you'll find plenty of uses for these photos. ☛

Idea file:

Picture talk

Here's an idea to help you get your students talking about a picture. Any interesting picture will do—artwork, a drawing, a photograph from the *National Geographic* or other magazine, or from a language teaching text such as the one in the preceding review.

An instructor's presence sometimes stifles the conversation, especially with shy students. Why not have them lead their own conversation? Students in small groups may have plenty to talk about. A picture will get them started, and if they need some questions to keep the conversation going, they can select a card from a pile you have prepared.

This activity works well with multi-level groups, can be adapted for any level of student, and could include a wide range of topics. You might use it to introduce a new topic, or to review an old one.

See the idea file card on page 10 for step-by-step instructions. ☛

Contents

Cultural activity:	
- Conversations about death	2
Minigrants winners:	
- "Family Reading Time"	4
- "ESL Yearbook Project"	5
- About the grants	6
Grammar grab-bag:	
- Making comparisons	6
Writing:	
- A Class Journal	8
Editorial:	
- Snow thoughts	9
Hints & tips:	10
Classified ads	11
News & notes	12

Hands-on English

Volume II, Number 5
January/February 1993

Hands-on English (ISSN 1056-2680) is published six times a year (Jan./Feb., March/April, May/June, July/Aug., Sept./Oct., Nov./Dec) by Hands-on English, P.O. Box 589, Dewitt, NY 13214 USA.

Copyright © 1993 Hands-on English

Subscription rates:

\$16 for regular subscribers,
\$10 (discounted rate) for volunteers or teacher's aides, \$22 (multi-user rate) for libraries or institutions. Single copies are \$4 each. **Postage & handling:** Canada and Mexico add \$4; outside N. America add \$10.

Permission to photocopy: This periodical is copyrighted. However, we invite teachers and tutors who have a paid subscription (or whose institution has a paid subscription) to make as many copies as they need for their own classroom use.

Please don't make copies for colleagues! We survive on the subscriptions of our readers.

Editor: Anna Silliman
(M.A., Teachers College, Columbia Univ.)
Consulting Editor: Karen Campbell

Address correspondence to the editor,
Hands-on English, P.O. Box 589, Dewitt, NY
13214 USA. Phone/fax (315) 445-0785.

Subscribe today!

Send this form with your check or money order (U.S. funds only) to the above address.

Please send me a subscription to *Hands-on English* for one year (6 issues). I enclose:

- \$16 for a regular subscription
- \$10 discounted rate for a volunteer or aide
- \$22 multi-user rate for a library/institution
- _____ postage/handling: Canada/Mexico add \$4.
Countries outside N. America add \$10.

Name: _____

Address: _____

Institution: _____

Position: _____

II-5

Cultural activity: Conversations about death

Contributed by Bobbie Anderson, ESL teacher in La Cygne, Kansas.

Some of our students recently asked us what to say in English when someone dies. We gave them a brief answer, but wished we had a better way to approach this topic.

For that reason we were very pleased to find this lesson by Bobbie Anderson, which provides some real-life information to the students in a clear, straightforward way, and which naturally leads to further discussion of adult topics.

The lesson on the next page should provide you with at least enough material for one session. You can read and discuss the conversation between Tom and Bob, then have the students read it together in pairs.

Each picture can be discussed in detail, and might lead to creating more dialogs. (An alternative way to present this is to cover up the vocabulary before copying the page, so that you and the students generate the new words one-by-one as you talk about the pictures.)

You'll want to allow plenty of time for this lesson, to give the students a chance to ask all the questions they want to.

Notice that on the next page, the suggested activities are presented to the **student**, not just to the teacher! This is a good practice with adult students. They should be able to participate in the lesson plan and help decide what to study. Also, even if the rest of the class *doesn't* do these activities, perhaps one or two students would like to do them on their own.

Current events

Another interesting follow-up activity, besides those listed, is to bring some newspaper obituary pages to class so the students can read and discuss them. If there is a news story about a well-known person who has recently died, the students might like to read and discuss that as well. ←

Conversations about death

Tom: Your uncle just died*?
I'm so sorry.
Tell me about it.

Bob: Yes. He passed away* yesterday.
We got the phone call last night.
He was a good friend.
I will miss him.

Tom: Will you go to the funeral?

Bob: Yes. We will drive there tomorrow.
The visitation will be in the evening.
The funeral will be at 2 p.m. the next day.
I'm sorry I'm crying.

Tom: That's O.K.
This is a time to cry and remember.



Feelings
grief
loss
sadness
sorrow

*died
passed away
passed on

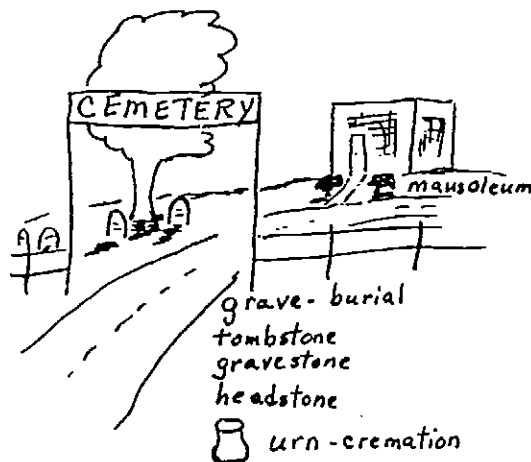

funeral home
mortuary
coffin, casket

Activities
visitation
viewing
wake
funeral
memorial service

Possible activities:

1. Discuss customs and procedures in the USA and your country.
2. Visit a funeral home. Ask what they do and why. Ask if your customs can be observed there.
3. Talk about how friends and neighbors help in time of death.
4. At the store look at SYMPATHY cards.

★ Minigrants '92 award winner: "Family Reading Time"

We're pleased to present this project by Georgiann Darter of the Adult Education Center in Dermott, Arkansas. We keep hearing about 'family literacy'—here we learn how this concept can be implemented and what the benefits can be!

The ESL *Family Reading Time* project began in the classroom with five sets of Mexican parents. They all had preschool to third grade age children, and were farm laborers with reading skills in the range of 3.6 to 9.0.

The first aspect of the project was a free discussion between the students and the instructor about their children. The key question was: What are some things you do with your children? Some of the parents had activity times with their families; others did not. Discussion centered around activities that could be used to help children prepare for school or help them with school

work. The parents did not do a great deal of reading and talking to their children in English, and reading just for the enjoyment of reading was not an activity they had thought of doing with their families. With this basis, the project then began by showing the parents two books they would be given to take home to read to their children.

The students were introduced to each of the Big Books they would work with in class. The instructor demonstrated reading the books and discussed vocabulary and comprehension. Next, the parents worked in pairs helping each other to read the books. Then, the parents practiced reading to each other in turns.

Before they took the books home we also worked on putting expression and excitement into the reading. We looked at the stories, pictures and other material in the books to see how many different activities could come from the books. After three sessions, the books were finally taken home, and both parents agreed to read them to their children.

The students selected *I Love My Family*¹ to read to their children first. They liked this book because it talks about things families can do together. The book could be used to teach English words for different members of the family—for example one page shows an aunt

helping a child to make puppets. Some of the women decided they wanted to know how to make puppets too. So, we made two different kinds—paperplate and paperbag puppets. Each mother took home enough materials for each child in her family to make a puppet. They planned to use the puppets to act out the stories.

In preparation we also used the *Let's Learn English Coloring Book*² for pictures of different family members, and the *Addison-Wesley Picture Dictionary* helped to reinforce the words with pictures.

The second book they read to their children was: *It's Pink, I Think*³. This is an excellent book to help children learn colors, numbers and the names of items of clothing.

"...they can be teachers and role models for their children..."

From what I observed, the best outcome of the project was the parents working together to read the books in English. The

parent involvement was excellent. They were serious about the task, but also enjoyed the process.

This activity provided a positive break from their normal routine of studies. At the same time it met a vital need in the daily life of the Mexican parents. They have a great desire to see their children succeed in an English environment. Importance was placed on the fact that they can be teachers and role models for their children to learn English.

After all the parents had completed their assignment to read the books at home, there was a follow-up session. Their response was very positive. They had found the activity to be enjoyable and profitable, and they left it with a request: "When can we do this again?"

Resources

1. *I Love My Family* by Kathleen Beal (1990 Addison-Wesley Co.).
2. *Let's Learn English Coloring Book* by A. Hazzan (1988 NTC Publ. Group).
3. *It's Pink, I Think* by Kathleen Beal (1990 Addison-Wesley Co.).

★ Minigrants '92 award winner: "ESL Yearbook Project"

This project was submitted by Barbara Smith-Palinkas, ESL teacher at District 113 Continuing Education, Highland Park, Illinois. She wrote: "It wa. a wonderful experience and an honor for me to receive this award. How many ESL teachers have said, 'If I only had a little extra money to do something special with this group...'? Your award allowed me to do that." We are pleased to present this report on her project.

At the beginning of the school year in September, I explained to the students that we had received a special grant to make a class yearbook. I explained that we would each have our picture taken and would write a little bit about ourselves. I explained that each student would get a copy of the book.

I brought in a 1966 and a 1992 high school yearbook and explained the American tradition of high school yearbooks. The students enjoyed looking at the books, and had a good time commenting on how everyone dressed during the 1960's.

As a group we then drew up an outline of information we thought each person should include in his/her story. We wanted something personal and something professional; we wanted to include the past, present, and future. Under personal, for example, we noted: name, country, family information, date of arrival in the U.S., etc; under professional we noted: education, work experience in the native country and here in the U.S., etc. Under future we included plans to stay here or to go back "home," educational goals, etc.

Students were given the outline as a guide and were free to write whatever they wanted. They were encouraged to begin writing their stories at home and bring them into class; a few actually did this! We ended up setting aside some class time to write and rewrite the stories; they just never seemed to have time to do it at home.

It took only two or three class meetings to get pictures of everyone. After the pictures were developed, I brought them in for the students to look at and to give their approval; retakes were done if necessary.

Once all the stories were in final form, they were collected and typed. Each student had a separate page containing his/her story and picture in the book.

As a group we then decided on a cover. We brainstormed in class and put all of the ideas

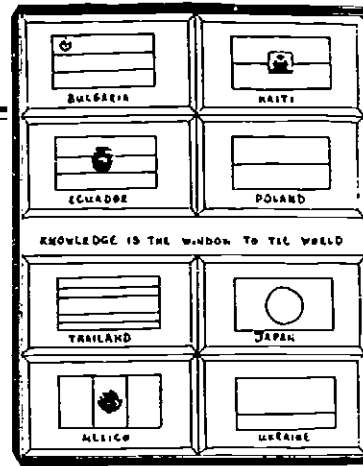

and suggestions on the board. One of the students suggested the phrase "Knowledge is the window to the world" and all of the students seemed to like that. A number of students wanted the flags of all the countries represented in the class (8 of them) to somehow be incorporated.

It was finally decided (by a vote) that the cover would be a window with eight panes; each pane would have one flag in it. The phrase would go across the middle of the page. One student volunteered to go to the library and get a book on flags and draw the cover.

Meanwhile, photocopies were made of each student's picture and story. Two students also drew pictures of scenes from their countries and these pictures were included in the book. We also included a sheet containing the signatures of all the students.

Once all the copies were made, we laid them out on two tables and formed a little assembly line. Each student went around and assembled his/her book and put it into a manila folder with his/her name on it.

The school district contributed special folders that had clear plastic covers and in which the pages could be thermally bound. This really made them look more like books; our other alternative was to staple the sheets together. After all the books had been put in a folder and bound, they were given back to the students.

The students then spent class time coloring the flags on the front cover. As students did this, there was a lot of talking and laughing going on. They read each other's stories and commented on them; they began to exchange their books and write little notes and sign their names.

During this project one student suggested that all students exchange addresses, both here in the U.S. and in their home countries. The addresses were then typed up, photocopied and distributed to all the students. ➡

About the Minigrants



Do you know about the *Hands-on English* Minigrants program? This spring we will be awarding 10 small grants (of \$100 each) to teachers or tutors of ESL for the development of an instructional project, to benefit their students. Applications for this year's grants are now available from our office, and will be due no later than April 30, 1993.

Last spring we awarded five grants. You can read about two of the winning projects here in this issue (pages 4-5). Reports on the other projects will appear in future issues.

We are proud of this program, because we feel it demonstrates our commitment to encouraging classroom instructors and tutors, and to helping them in a practical way. We are also pleased to give you some recognition for your ideas and for the work you are doing!

Another reason we encourage our readers to apply is in order to learn about the grant-writing process. Writing a proposal for a small grant is often a first step in applying for larger grants from other agencies. There's no better way to learn how to do it, and we've designed our application process to be educational for you.

Don't be shy—apply!

Let us know if you would like further information and an application form. Write:

Hands-on English
Attn: Grants Manager
P.O. Box 589
Dewitt, NY 13214 USA.

Or call (315) 445-0785. ↵

Grammar grab-bag:

Making comparisons

Here's an example of how a grammar lesson can be expanded to include an opportunity for students to express themselves, using the new structure in a meaningful way.

On the next page are some samples of sentences students wrote as part of a lesson on comparatives. We interviewed their teacher, Joan Uchitelle, to find out exactly how this was done.

She explained that the class was working from a grammar text called *Basic English Grammar* by Betty Azar (1984 Prentice-Hall, Inc.). The students had worked through many of the exercises and had learned structures such as: *as old as*, *bigger than*, *prettier than*, and *more famous than*. They did most of these exercises orally in class.

The book suggests students write a comparison of their hometown and this city, so Joan asked her students to write 5 to 10 sentences, comparing their home city (or country) to their new one. For more advanced students, she asked them to write a paragraph.

When the students had written and handed in their sentences, she found that many of the comparisons were very interesting, so she took a sample sentence from each student, typed up a list of their sentences, and gave them to the class for everyone to read. This gave the students an opportunity to talk about some things that were important to them.

The entire lesson therefore included structured grammar practice, writing, reading and discussion.

Tip for tutors:

Even if you're not formally teaching this grammar structure, the sample sentences on the next page could make interesting reading and discussion material for you and your students. Then, the students might want to compare their home country or city to the one they are now living in. Do this orally, then write down the students' sentences in the correct form. ↵

It's Different Where I Come From

Sentences using comparatives

1. The people in my country **are happier than** here.
2. The people in my country (Honduras) **are thinner than** in this country.
3. Bananas **are cheaper** in my country **than** in this country.
4. Lima has **more interesting** churches **than** this city.
5. The family **is closer** in my country (Dominican Republic) **than** here.
6. My country **is prettier than** this country.
7. In my country (Columbia) life **is quieter than** in this one.
8. There are **fewer** universities in Peru.
9. You have to stay **longer** in the hospital after an operation in Japan.

However in the USA. . .

1. The people in this city **are funnier than** in my city. (Lima)
2. Old women wear **prettier** clothing in this country.
3. The men in this country take **more** responsibility for their families.
4. American houses **are bigger than** Japanese.
5. There are **more** foreigners here **than** in Japan.
6. We can find **more** animals in America **than** in Japan.
7. There are **more** women drivers in America **than** in Japan.
8. Food in this country **is cheaper than** in my country.
9. Beef **is cheaper here** than in Japan.
10. The summer **is hotter**, the winter **is colder**.

A lesson from an intermediate level ESOL class
at the Adult Learning Center, BOCES Southern Westchester, NY.
Teacher: Joan Ucinitelle

Writing: The Class Journal

Many readers have told us they are looking for writing activities. We're pleased to bring you this one by Lucie Germer, ESL teacher in Marlborough, New Hampshire.

Lucie has taught ESL to adults, high school and elementary students and says many techniques work well with all ages. The Class Journal was done with a group of high school students but would be perfect for any adult class.

At the first class meeting I showed the students a large notebook. Inside I had written:

Here is a journal for the whole class. If someone gives you the journal you must write in it, either during class or at home. Then give it to someone else in the class. You must write at least three sentences in English. You may write anything, except for things that are offensive or that hurt someone's feelings. You may answer someone else or you may start a new topic. You don't have to sign your name, but you do have to put the date. Don't change anyone else's words.

We went over the instructions. Then I handed the journal to a quiet Vietnamese student.

"Me, teacher? Why me?" But he came to the next class with:

The best place I think it's good to go out for pizza is Athens Pizza. Because it cheap and tast good. and also it's right downtown. It's good place for family to go too.

Although he had worked hard on it, his writing was less stilted than in his formal compositions. He handed it to a German student, who was more interested in politics than pizza, and wrote admiringly about Ross Perot, "He knows a lot of the biggest problem America has: money!" Then he passed it on to a Russian student who discussed the McDonald's in Moscow.

Over the months we've kept the journal circulating. One change we've made is to insist on names as well as dates so that everyone knows the journal is shared fairly.

We've discussed politics:

I think Clinton is going to be a good president. But is going to be hard to decide for all the country and sometimes for the world. I think the person who want to be president is crazy.

Personal problems:

I don't want to work today I just want to stay home and sleep.

So stay home and sleep. If I were you I would stay home and sleep to.

American holidays:

I had a wonderful Thanksgiving. My sister she made a lot of foot. . .

And there were complaints about work, family, and the weather.

During our last class before Christmas vacation, the students read their selections aloud. One of the students pointed out that the whole first part of the year was in the journal, "everything we've done and thought."

Why it works

What are the advantages of the class journal? It gives these intermediate students a chance to write to a known audience, not the teacher. They are developing an informal style. Peer comments encourage them to take more care with handwriting and punctuation (not to mention spelling—there's one student who will never confuse "food" and "foot" again!). Since many of the students see each other only in class, the journal helps them know each other better. I also helps me plan grammar lessons. For example, I've gone over several entries and realized that the class is doing better on irregular pasts and worse on pronouns than I thought. Finally, the class journal doesn't take much extra class time. Once it's rolling, the students take responsibility for writing on their own.

While the journal would work well for more advanced students, there is obviously a lower limit. In general, students need a certain basic level of reading and writing to benefit from the class journal. My students are all literate and do other writing in class.

Now what?

I'm already planning my wind-up activity for the journal: We'll have a class raffle—the money to be used for a class treat, and the journal given to the lucky winner. But I think I'll photocopy it first. It really is a wonderful way to remember them. 🐾

Editorial:

Are we different or the same?

Those of us who work with people from other cultures need to question our own underlying assumptions from time to time. Often they are based on outdated ideas, that anthropological, neurological or linguistic research has put to rest with new discoveries.

For example, years ago common wisdom said that Eskimo peoples had hundreds of different words for *snow* in their language, whereas in our language we have only one—"snow." The implication was that Eskimos think differently; that is, they possess concepts and subtle gradations of perception that we do not, presumably because of the importance of snow in their environment.

As it turns out, this observation about the differences in language and "thinking" may have been completely wrong.

First of all, the number of words and terms for *snow* in Eskimo languages was probably wildly exaggerated in early studies. Secondly, those of us non-Eskimos who have contact with snow quickly develop huge specialized vocabularies to deal with it!

Just for fun, we decided to count all the words for snow in English we could think of (if we've missed any, please let us know!)

GENERAL—snow, snowflakes, snow crystals, snowdrift and snowbank (we won't count snowball or snowman)—5.

HIGHWAY CONDITIONS—a dusting of snow, heavy (or light) accumulation of snow, wind-driven snow, drifting snow (this is different from snowdrifts) slushy snow—a total of 10.

METEOROLOGY—snowfall, snow showers, snow flurries, snow squalls, lake-effect snow, heavy snow, snowstorm, blizzard (we won't count sleet)—brings us to a total of 18.

SKIING CONDITIONS—wet snow, hard-packed snow, loose powder, packed powder, granular snow—23.

Not a bad list, considering we are leaving out snow-related terms such as all the variations of frost, sleet and ice. We're also ignoring medical conditions such as snow-blindness, or 'white-out,' and the problem of being snowbound and getting cabin fever.

If we turned to literature to find poetic references to snow we would surely find many more descriptive terms for the white stuff (Aha! 24!).

And what about common **IDIOMS** in our language? Are you *snowed under* by too much work? Does your laundry come out *as white as snow*? Was that salesman telling the truth, or was he just doing a *snow job*? Do you have the feeling this editorial is starting to *snowball* out of control?

If you didn't know better, you'd think your culture was obsessed with snow.

Are there differences between cultures? Certainly. But we should be careful—something that appears strange and different in another culture may not be so strange or different in reality when both cultures are inspected closely. ↵



We're feeling pretty up-to-date. . .

The *Hands-on English* office now has a **fax machine**, so you can send us your hints and tips by fax if you want to, at our usual number (315) 445-0785.

Of course, you can still telephone us, or write to us, but please don't send carrier pigeons—the cats might eat them.



There was a message here from one of our readers...now, where did it go??



Picture talk

Purpose: Speaking practice; vocabulary development
Level: Any level or multi-level
Time: About 20 minutes, or up to 1 hour
Materials: Interesting photographs or pictures
3x5 cards for discussion questions

1. Before the session, prepare a few discussion questions about each photograph and write them on 3x5 cards.
2. Divide the class into small groups of 2-3 students each.
3. Give each group a photograph to discuss. Also give a time limit (such as 15 or 20 minutes) so students know what to expect.
4. Supply each group with a stack of 3x5 cards with questions on them about the picture. Place the cards face down, and explain that students can take a card if they need an idea to talk about.
5. As the students talk, you can circulate to answer questions about vocabulary.
6. When the time is up, have each group tell the class what they talked about.
7. As a follow-up, students could take the pictures home and write something to be handed in.



Hints & tips

Color pictures

Know where to get large, glossy color pictures to use with your students? Here's a hot tip—in many stores left-over 1993 calendars are now selling at 50% off, or cheaper! And if you find some with art reproductions, see our next issue for an article by Judy Gex on using art in ESL.

Speak English. . . please??

In our last issue, we published an article about getting your students to speak English in class, instead of relying on their native language for help. Upon reflection, though, we decided that our title, "Speak English, please!" has a nagging quality to it. We have heard ourselves giving this admonition to students, and it's not very effective.

Instead of nagging, we think it's more appropriate, *especially* with adults, to invite, encourage and challenge the students. So we came up with a slogan that we think is more in keeping with this attitude—"Try to speak English!"

If you feel your students need reminding from time to time of the effort they should be making,

copy this button on bright-colored paper, and pin it to your lapel. Besides helping to focus the students' attention on the task at hand, the slogan also indicates to them that you understand it's not necessarily easy to speak English. ↵

**Try
to
speak
English!**

EDUCATIONAL SHOWCASE

Your ESL Connection

Providing ESL/EFL Programs for All Ages

The Largest Collection of ESL Materials
on Display in the Midwest

- * Place orders by mail or fax: (313) 680-1052
- * UPS delivery in 5 to 10 days of in-stock items
- * We meet publisher's prices AND beat the service
- * To order or to receive our comprehensive ESL catalog write to:



EDUCATIONAL
SHOWCASE
1334 Wheaton Street
Troy, MI 48083
(313) 680-0860



Intercultural
PRESS

Your direct source for books, videotapes,
and training materials on intercultural
relations, cross-cultural adaptation,
diversity and multicultural education.

Call or write to receive a free copy of our
latest catalog.

P.O. Box 700 • Yarmouth, ME 04096
(207) 846-5168 • Fax (207) 846-5181
1-800-370-BOOK (in the U.S.)

Classified ads

Your ad goes here

Our "classified" section gives you a chance to network with people and find out about products & services of interest to you.

Classifieds can include notices about schools, courses offered, publications, new products, special offers or requests from our readers.

To place a classified ad, send your notice of 30 words or less with US \$10 (or if you are a subscriber, take a DISCOUNT of 50%) to:

Hands-on English

P.O. Box 589

Dewitt, NY 13214 USA

Our phone/fax number is (315) 445-0785.

Publications

Families: 10 Card Games. 40 brightly colored cards. Practice questions/answers about clothing, money, transportation, time, feelings. Builds conversation skills, confidence. Fun at any age. \$8.50. *Pro Lingua Associates.* (800) 366-4775.

Back issues of *Hands-on English* are now available at US \$4 per copy (this includes shipping costs). Let us know which issues you're missing! See our address above. ☛

News & notes

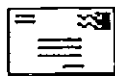

Upcoming conferences

If you need more information about any of these conferences, call *Hands-on* at (315) 445-0785.

- ◆ March 11-13, 1993—International Reading Association (IRA) Eastern regional conference in Rochester, NY.
- ◆ March 18-20, 1993—BC TEAL in Victoria, BC Canada.
- ◆ March 25-26, 1993—Louisiana TESOL in New Orleans, LA.
- ◆ March 25-26, 1993—California TESOL in Monterey, CA.
- ◆ April 2-3, 1993—Massachusetts TESOL in Boston, MA.
- ◆ April 2-3, 1993—Wisconsin TESOL in Eau Claire, WI.
- ◆ April 3, 1993—Northern New England TESOL in Portland, ME.
- ◆ April 3, 1993—Connecticut TESOL in Meriden, CT.
- ◆ April 13-17, 1993—International TESOL convention in Atlanta, GA.



Happy New Year

In the Chinese calendar, this is the year of the rooster. In a fit of multiculturalism, the U.S. Post Office recently issued an orange-red Chinese New Year stamp with a rooster on it, with English as well as Chinese writing.

Ethnic food

If you like cooking food from other cultures, a great resource is "The Frugal Gourmet On Our Immigrant Ancestors: Recipes you should have gotten from your grandmother" by Jeff Smith. It has recipes from 35 different cultures. And best of all, it's now out in paperback!

Welcome K-12 teachers

We've recently had a number of new subscribers to *Hands-on English* who teach ESL to K-12 students. We're delighted, of course, and we're eager to hear how our activities work for you. ↩



A periodical for teachers and tutors of adult ESL

P.O. Box 589
Dewitt, NY 13214
USA

ADDRESS CORRECTION REQUESTED

January/February issue



Hands-on English

A periodical for teachers and tutors of adult English as a second language

Tools & techniques:

Lesson planning—after the fact

How to prepare?

Has this ever happened to you? You spend hours or days preparing a lesson that just doesn't work. Then on another day when you're not even prepared you have the best lesson ever. Why did one work and not the other? How can you prepare for next time?

There's something about teaching ESL to adults that makes it very difficult to prepare lessons. This may be because attendance is not always regular in adult programs. You don't know who will be there, or whether you'll have the same group of students as last time. Ongoing enrollment means you may have new students to incorporate. Multi-level classes means the materials you bring in may not be appropriate for many of the students. The problem can seem overwhelming.

A technique

Here's a technique that will help you to prepare more effectively for your ESL lessons. It is effective both for a classroom situation and with tutoring. It's so simple, you may think it's ridiculous, but it really works—prepare for the next time immediately after each lesson.

That is, take some quiet time after each lesson to think carefully about what happened. Make some notes about what was successful. List any new items that came up during class so you don't forget them. Visualize each student and what they did during the session.

Then, decide what you should follow up on next time. Plan some review of any new items that came up. Decide how you can change your approach to give students more opportunities

to participate. Think about expanding on what was just learned, or filling in a gap in the students' knowledge.

Write down a tentative plan for the next lesson while your students are still vividly in your mind, and you'll be surprised how much more effective your planning will be. Your students will sense more continuity from session to session, and your written notes will provide an invaluable record of things that worked for you, and why.

"Postparation"

You could call this technique "*postparation*" instead of *preparation*, because it takes place after the fact. Like any self-help technique, it requires discipline to do it, especially since teaching is very tiring work, and after a lesson you may feel more like resting than planning!

Try "postparation" for three weeks, and see what a difference it makes. ➔

Contents:

Cultural activity:	
- Nine ways to use art in ESL.....	2
Tools & techniques:	
-Gadgets for teaching.....	4
Grammar grab-bag:	
-Using the verb 'have'.....	5
Crossword puzzle:	
- Multi-level puzzle on parts of the body.	6
Minigrants award winner:	
- Snapshots in English.....	8
Index to Volume II.....	9
Hints & tips.....	10
Letters.....	10
News & notes.....	12

Hands-on English

Volume II, Number 6
March/April 1993

Hands-on English (ISSN 1056-2630) is published six times a year (Jan./Feb., March/April, May/June, July/Aug., Sept./Oct., Nov./Dec) by Hands-on English, P.O. Box 589, Dewitt, NY 13214 USA.

Copyright © 1993 Hands-on English

Subscription rates:

\$16 for regular subscribers.
\$10 (discounted rate) for volunteers or teacher's aides, \$22 (multi-user rate) for libraries or institutions. Single copies are \$4 each. Postage & handling: Canada and Mexico add \$4; outside N. America add \$10.

Permission to photocopy: This periodical is copyrighted. However, we invite teachers and tutors who have a paid subscription (or whose institution has a paid subscription) to make as many copies as they need for their own classroom use.

Please don't make copies for colleagues! We survive on the subscriptions of our readers.

Editor: Anna Silliman
(M.A., Teachers College, Columbia Univ.)
Consulting Editor: Karen Campbell

Address correspondence to the editor.
Hands-on English, P.O. Box 589, Dewitt, NY 13214 USA. Phone/fax (315) 445-0785.

Subscribe today!

Send this form with your check or money order (U.S. funds only) to the above address.

Please send me a subscription to *Hands-on English* for one year (6 issues). I enclose:

- \$16 for a regular subscription (one user).
- \$10 discounted rate for a volunteer or aide.
- \$22 multi-user rate for a library/institution.
- postage/handling: Canada/Mexico add \$4. Countries outside N. America add \$10.

Name: _____

Address: _____

Institution: _____

Position: _____

Check here if this is a **Renewal**. II.6

Nine ways ...

By Judy Coppock Gex. Judy teaches ESL at LaGuardia Community College in Long Island City, NY. She presented a demonstration of these techniques at the New York State TESOL conference in October, 1992.

I use art reproductions and photographs frequently in the classroom. These can be from slides, posters, calendars, postcards or from books. Here are nine examples of the way I use art.

1. Write about a picture. I hung pictures from the Magritte calendar around the classroom. The assignment was: Look at the pictures. Choose one. Write about it for 20 minutes.

The next time the class met, the students saw the pictures again with correctly typed versions of their writings hanging under them. They then spent some time perusing the stories, reading what everyone had written.

(Showing the students a corrected copy of their writing is a good way of providing correction for them without coloring their drafts with red ink!)

2. Discuss an issue. For example, I showed the students Ribera's picture of Isaac giving Esau's blessing as the first son to Jacob. After talking about the picture, I directed them to discuss the importance of birth order in their cultures and/or in their families, and what difference their birth order had made in their lives. This was a lively discussion, which then provoked a lot of interesting writing.

As a follow-up, we took a trip to the Metropolitan Museum in New York to see the Magritte and Ribera exhibits. (Museums in many cities offer teacher workshops which might provide you with more materials and ideas for your classes.)

3. Vocabulary puzzles. 'Postcard puzzles' can be self-correcting, provide interesting group work and call attention to the details you want your students to notice in a picture. They are excellent vocabulary builders.

One way to do this is to cut the postcard into equal rectangular strips and put the appropriate answer on each one. On the inside

...to use art in ESL

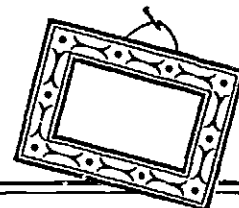

of a manila folder, draw around the postcard and strips and write the questions. The students work together and place each correct answer strip on top of the question. When they finish, they close the manila folder, flip it over and open it from the other side—if they see the completed postcard picture, they know their answers were correct.

An idea that I got at a Marion Klar workshop (New York Public Schools, NYC) was cutting a postcard in shaped pieces like a jigsaw puzzle, and outlining the pieces in put-together form on a 4x6 card. In each space on the card, write a sentence with a blank. Put the answer on the matching postcard piece. Students can work in small groups to assemble the puzzle and work on the English in the sentences. (Have a couple more puzzles than you have groups so that you can keep everyone engaged.)

4. Sentence combining. Gail Marks (The New School, NYC) shared this idea of using pictures for pairwork in sentence combining. Give each pair of students a picture, accompanied by two sentences. These can be written on a post-it note, or an index card taped to front side of the picture. Put the answer on the back side so the students can get the practice and the information. Postcards of Historical or cultural figures, places, paintings and animals work equally well—getting the information and the illustration in front of the students at the same time.

5. 'Total physical response.' Nancy Cloud (Hofstra University, Hempstead, NY), in a presentation at the NYS TESOL conference, suggested TPR activities with pictures you can get both in poster and postcard form. You can have the poster in front of the room, and each student can have a copy of the postcard to point things out on. She used the Renoir girl with a watering can from the National Gallery.

6. Scrambled paragraphs. I made scrambled sentence paragraphs for sets of three pictures by Seurat. I had three groups of students working at the same time. I wanted each group to work through the set that included Sunday on Grand Jatte, so we could then watch a small section of Sondheim's

"Sunday in the Park with Georges." At the end of the class recapped what they had learned about Seurat's biography and painting style.

7. Video. I make information-gap activities of the biographies of artists found on the sound track of art videos available for purchase or rent from Home Video, 364 Main Street, Palmer, MA 01069. Tel. (413) 283-7822. After the students have done the activity, we watch the tape.

8. Art news. CBS Sunday Morning is a good source of close captioned segments on artists when major shows open in New York.

9. Calendars. I prepare questionnaires for group work with museum calendars. This provides lots of information about inexpensive activities available in the city. ↩

___ a gauze curtain there is a beautiful window.
You can see the sea, the horizon and some greenery ___ the balcony.
There is a mirror ___ the dressing table.
Sunlight is streaming ___ the balustrade.
A violin case is resting ___ an armchair.
The dressing table is ___ the French doors.

Example of a postcard puzzle. When assembled in the correct order, the reverse side of the strips will show Matisse's painting, *Interior with a Violin Case*.

The questions are written on the inside of a manila folder.

The answer strips are a cut-up picture postcard.

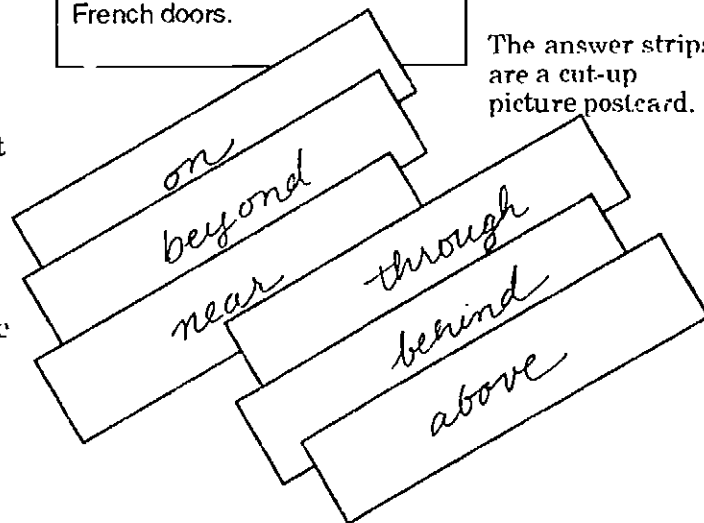

Gadgets, widgets, doohickeys & gizmos

Devices that make teaching easier

Sometimes it's the little things that make a difference. For example, almost everybody uses **Post-it™** Notes in some way. They are useful for marking pages, taking notes, indexing, leaving messages, etc. In fact, they are so useful it's almost hard to imagine life without them!

We thought we should gather together a list of other items that might make your teaching and tutoring easier and more effective. Here's a list of some you should know about:

① **Post-it™ Correction & Cover-up Tape.**

This white tape must have been invented with ESL teachers in mind! It attaches securely to a page, can be written on with pencil or pen, but then lifts off without damaging the paper.

Use it for quickly adapting or changing a lesson for your students before photocopying. For example, to cover up instructions that are confusing, to edit out-dated examples in a grammar exercise, or to personalize a story by inserting the names of class members...etc.,etc.

The tape comes in 1-line, 2-line and 6-line widths, and all of these are useful to have around. The price is under \$2 for a roll. Available in stationery or office supply stores.

② **Overhead transparency film for copiers**

You can now make an overhead transparency of any page, using a photocopy machine and special transparency film designed for photocopiers. You can buy this film yourself for \$8 - \$10 for a package of 20 sheets (companies that make this include 3M and Denuison) but before using it please make absolutely sure that the machine you are using can make transparencies!

Most copy centers will now make a transparency for under a dollar, so you could save hassle by just taking your page to them.

③ **Laminating.**

Laminating your teaching aides such as pictures, artwork, flashcards, gameboards and instruction cards can make them more durable and more attractive. But, a good laminating machine costs more than \$500! If your program or school doesn't have one, there are a couple of alternatives.

For regular 8 1/2 x 11 pages, there are many different kinds of plastic sheet protectors available. Some open at the top, some at the sides. If you buy a big box of 50 or 100, you might get them for under 10¢ each. Because these sheets don't 'stick' to your page, they are reusable almost indefinitely.

For smaller-sized items, there are heavy-duty, self-stick laminating sheets available (ask at an office supply store). These work well but at \$2 - \$3 a sheet are pretty costly. Copy centers can often do real laminating for you, in about the same price range.

For quick, budget 'laminating' of small items such as cards or small pictures, the best trick we know is to use **clear mailing tape** (sometimes called package sealing tape). It comes in a 2-inch wide roll, is very strong and won't yellow or get sticky. This is made both by 3M and by Manco, and is available at stationery and office supply stores for around \$2 a roll. Many post offices also sell this kind of tape.

④ **Glue stick.**

Maybe everybody knows about this already, but we've found the best way to mount paper onto tag-board or poster board is to use a glue stick. Usually this comes in a tube about three inches long. Many companies make this now—the best kind used to be UHU by FaberCastell®.

Unlike just about every other kind of glue, it doesn't wrinkle the paper, has no fumes, isn't messy, is easily portable and lasts a long time because it doesn't dry out.

⑤ **Chalk holder.**

If you tend to forget where you put your chalk during class, a chalk holder makes it easier to find, and keeps the chalk from rolling off of tables. It also protects you somewhat if your hands are sensitive to chalk-dust. These small metal holders are available from school supply companies or sometimes at business supply stores.

Help!

We need some suggestions for ways to attach pictures and papers to walls. Concrete block walls seem to create the most difficulty. If you have a method that works, write to *Hands-on English* and tell us how you do it! We'll publish your suggestions in our next issue. 🐾



"Creature Feature"

(Using the verb "have"/practice with plurals)

This activity was sent to us by Michelle Rhodes in Youngstown, Ohio, where she teaches at O.C.C.H.A. (Organización Cívica y Cultural Hispana Americana, Inc.). The art work was contributed by two of her students. Michelle reports that the students all had a lot of fun with this activity!

Here's a great way to help your students learn the parts of the body, while learning to use "have" correctly at the same time. The activity can be done in 20 or 30 minutes, and works with any level of student, although beginners may benefit the most from it.

Preparation

In a previous lesson, introduce the vocabulary for parts of the body to your students (or review it with them if they already know it). There are many ways to do this. For example, see page 6 of this issue for a crossword puzzle on the parts of the body.

Bring some drawing paper to class, as well as copies of a model "creature" you have prepared in advance.

How to do it

Show the students your creature with its odd number of body parts. Tell them about your creature, saying "It has 5 heads" etc. Next, ask them some questions: "How many eyes does it have?"

Now hand out the drawing paper and assign each student to create his or her own creature, with an unusual number of body parts. When the students have finished drawing, have them describe their creatures orally. They can talk with a partner, a small group or the whole class.

Finally, have the students write a few sentences about the creature they created. Beginning students will write simple descriptions: "It has seven legs." More advanced students can use some descriptive adjectives, such as: "It has one short arm and one long arm."

Follow-up for listening practice

Have one student tell a partner how to draw a creature, with out the partner's seeing the first person's picture. For example, a student might dictate: "It has six legs," etc. Then compare the pictures.

Why it works

An atmosphere of silliness can sometimes encourage reluctant or shy students to participate. By 'inventing' a creature, students are investing something of themselves into the lesson, which means they are talking about something that is meaningful (even if it is silly). The exercise emphasizes what each student knows, not what he or she doesn't know. ➔

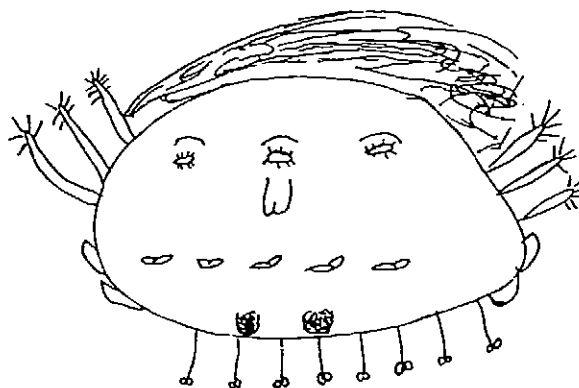

It has a lot of hair.
It has six arms.
It has thirty-five fingers.
It has three eyes.
It has one nose.
It has five mouths.
It has two chins.
It has eight legs.
It has sixteen toes.
It has one face.
It has four ears.
It is an ugly drawing.



It has a lot of hair.
It has 3 heads.
It has 5 eyes.
It has 4 ears.
It has one nose.
It has 2 mouths.
It has 4 arms.
It has 4 hands.
It has 12 fingers.
It has 3 legs.
It has 3 feet.
It has one chest.
It has 4 elbows.

Multi-level crossword puzzle: Parts of the body

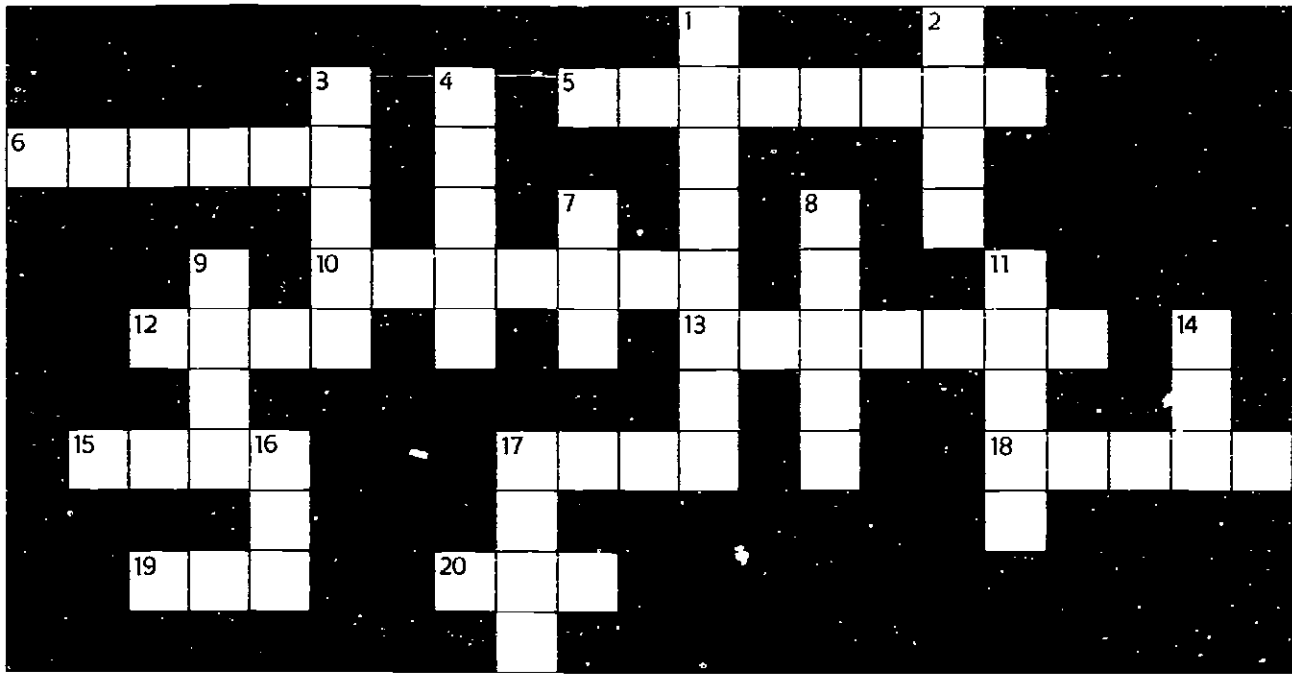

Level A

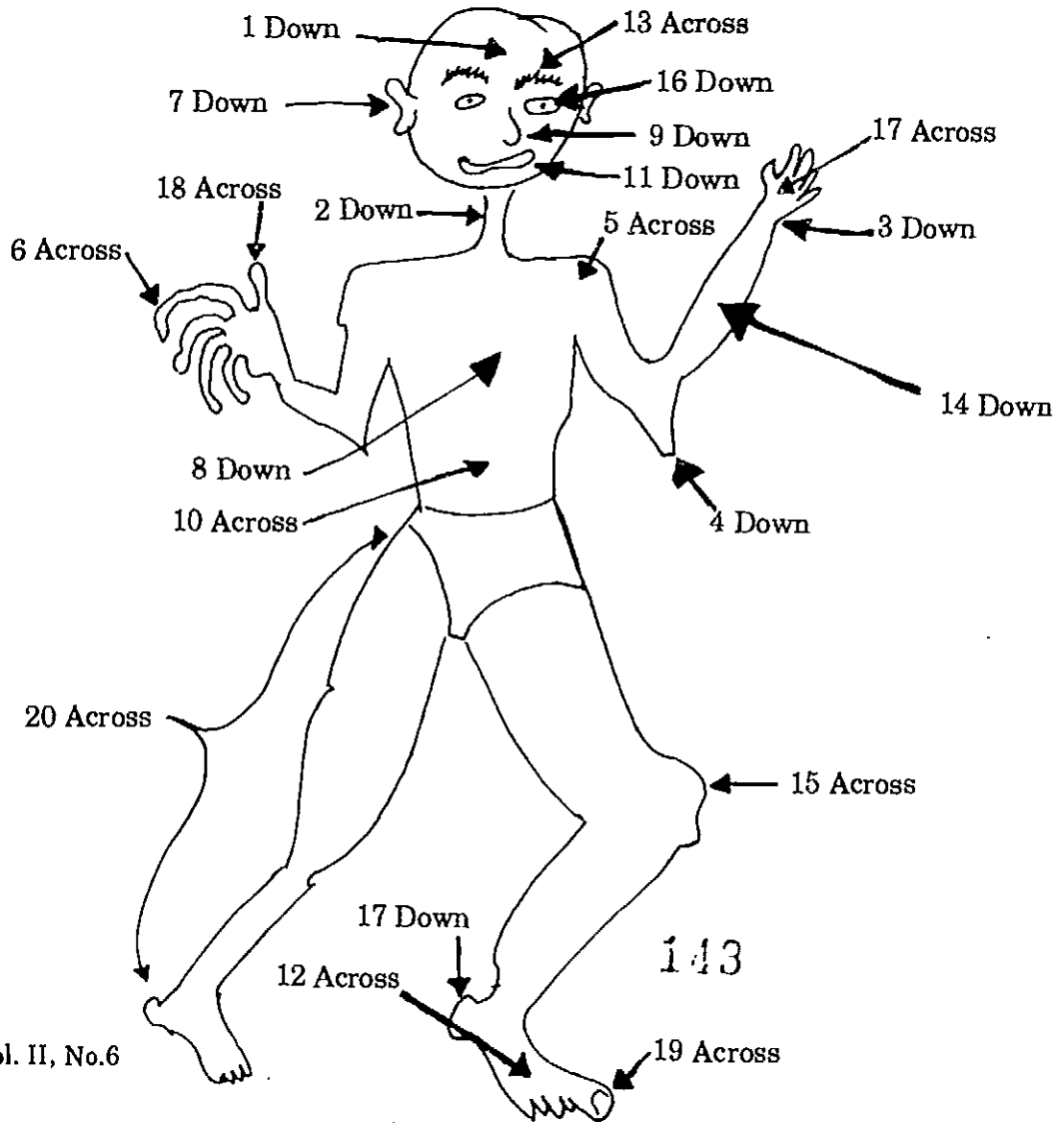

Level B clues

Across

5. This part is at the top of your arm.
6. You have five of these on each hand.
10. This part is in the middle of your body.
12. This part is at the end of your leg.
13. This is the hair above your eye.
15. This part is in the middle of your leg.
17. This part is at the end of your arm.
18. This is a special name for the shortest finger.
19. You have five of these on each foot.
20. Your thigh, knee, calf and ankle are all part of one _____.

Down

1. The front part of your head, above your eyebrows, is called the _____.
2. This part is between your head and your shoulders.
3. This part is between your hand and your arm.
4. This part is in the middle of your arm.
7. This part is on the side of your head.
8. Your heart is inside your _____.
9. This part is between your eyes and your mouth.
11. This part is above your chin.
14. Your shoulder, elbow and wrist are all part of your _____.
16. You have two of these on your face.
17. This part is the back of your foot.

Level C clues

Across

5. Some people carry a bag on their _____.
6. You use this part of the body to point at something.
10. After you eat, your _____ is full.
12. You stand on this part.
13. If you are surprised, this part of your face moves up.
15. You can bend your leg at the _____.
17. You can wave this, or use it for shaking.
18. If we like something, we point this part up. If we don't like something, we point it down.
19. This shoe is too small. It hurts my little _____.
20. If you break your _____, you can't walk for a long time.

Down

1. If you frown, people will see wrinkles on your _____.
2. If you turn your head, you must twist your _____.
3. This is the place where you put your watch.
4. The man sat down and put his _____ on the table.
7. You need this part for listening.
8. Your heart is in your _____.
9. You can breathe with this part, unless you have a cold.
11. You use this part for speaking and eating.
14. The woman carried the baby in one _____.
16. You use this part when you wink.
17. When you walk, you put your weight down on this part first, then on your toes.

How to use the Multi-level crossword puzzle

This puzzle is designed to work with three levels of students—if you have a multi-level class, all the students can work on the same puzzle, but at different levels of difficulty.

Level A—The clues are on the picture. Beginning-level students could use an English picture dictionary or a native language dictionary to find the answers.

(Note that for **pre-literacy** students, Level A is too complicated. For them, eliminate the puzzle altogether, and use the picture only. 'White out' the clue numbers and provide blank lines for them to write the answers on instead.)

Level B—The clues in Level B are language-based, and so require some thinking in English to solve. But they are very straightforward and refer mostly to the location of the body parts, and so would be good for advanced beginners or low intermediates.

Level C—These clues require much more background knowledge of English to solve, and work best with intermediate or advanced students. ➡

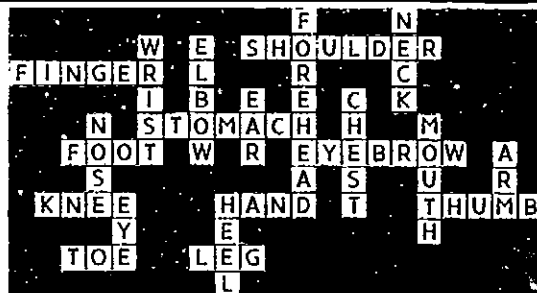

★ Minigrants '92 award winner: "Snapshots in English"

Student-made lessons about a field trip

We're pleased to present this report from Bernadette Schadewald on the Minigrant project at Hogar Hispano in Arlington, Virginia. The students were Spanish-speaking adults who immigrated to the U.S. from South and Central America. They ranged in age from about 20 to 60 years old, and came with different educational backgrounds.

The purpose of the project was to increase the English vocabulary of the students. We did this by going to the Smithsonian Institution (in Washington, D.C.) and having the students take photographs of things that they wanted to know more about. The students then used their own snapshots to learn the words for those objects in English.

First, the class was instructed on the nature of the project. They were given some background information on the museums, and examples of what to photograph. They were also shown how to use the disposable cameras.

The field trip

We made two visits to the Mall in Washington, D.C. At the National Air and Space Museum the students saw airplanes, telescopes and Apollo 11, and discussed the first flight made around the world. At the Hirschhorn Sculpture Garden, the class was interested in what materials were used, such as bronze, to make the sculptures. At the Museum of Natural History the class saw many animals and birds, and an exhibit on ecosystems. During these visits they took many photographs of things that interested them.

In class

The photographs were developed, and then discussed in the next class. The students used glue and poster board to mount the photographs, and magic markers to write descriptions about each one.

To encourage a group discussion and help them practice their conversation skills, I distributed some written questions asking the students what they liked about the trip. I also asked them to underline the verbs on the handout and to identify the verb tenses.

Results

The hands-on approach of this project produced very positive results. Not only did the students increase their English vocabulary, but they learned more conversation skills and practiced using different verb tenses with their expanded vocabulary.

It seemed that the students more easily recalled the words of the objects that they had photographed themselves. The project also increased the students' interaction among their fellow students. Learning was facilitated in a relaxed atmosphere, and the students' horizons and vocabulary were expanded by the experience. ➔



About the Minigrants



Do you know about the *Hands-on English* Minigrants program? Last spring we awarded five grants to teachers or tutors of ESL for the development of an instructional project, to benefit their students.

Applications for *this* year's grants were due on April 30, 1993. You can read about the winning projects in future issues. If you'd like to apply for a 1994 grant, you can request an application form (they will be mailed starting in the fall of '93).

We are proud of this program, and are pleased to give you some recognition for your ideas and for the work you are doing with ESL students!

Index to articles in Volume II.

Advertisers

- American English Publications. II-1,2,3,4.
Dominie Press. II-3.
Educational Showcase. II-1-6.
Intercultural Press. II-3,4,5,6.
Literacy Volunteers of America. II-3,4.
Pro Lingua. II-3,4,5,6.

Authors

- Anderson, Bobbie. "Conversations about death." II-5, p.2.
Armstrong, Fiona. "One question interview." II-1, p.6.
Curling, Karen. "Talking about testing... a lighter look at ESL placement testing." II-1, p.8.
Darter, Georgieann. Minigrants award winner: "Family Reading Time." II-5, p.4.
Germer, Lucie. "The Class Journal." II-5, p.8.
Gex, Judy. "Nine ways to use art in ESL." II-6, p.2.
Rhodes, Michelle. "Creature Feature." Using the verb *have*. II-6, p.5.
Schadewald, Bernadette. Minigrants award winner: "Snapshots in English." II-6, p.8.
Smith-Palinkas, Barbara. Minigrants award winner: "ESL Yearbook Project." II-5, p.5.
Uchitelle, Joan. "English names and nicknames." II-1, p.5.

See also: **Hints & tips**

Cultural activities & info

- Conversations about death. II-5, p.2.
Cooking measurements. II-4, p.4.
English names and nicknames. II-1, p.5.
Making a pumpkin pie. II-4, p.5.
Nine ways to use art in ESL. II-6, p. 2.

Editorials

- Are we different or the same? Words for *snow* in different languages. II-5, p.9.
Avoiding stress and "burn-out." II-2, p.1.
Promoting democracy. II-1, p.1.
The loneliness of an ESL instructor... II-4, p.9.

Grammar grab-bag

- Comparatives. "It's different where I come from." II-5, p.6.
Modals of ability in past and present. "Now I can, but before I couldn't." II-1, p.4.
Present perfect with adverbs of time. "He's been in the news recently." II-3, p.6.

- Relative clauses with *who*. "He's the one who got the gold." II-2, p.4.
Using the verb *have*. "Creature Feature." II-6, p.5.

Group activities

- Conversation starters: Talking about sports. II-2, p.5.
Folktale news reports. Role-playing the characters in popular tales. II-3, p.2.
A friendly interview. Conversation activity, getting to know each other. II-4, p.8.
One question interview. A survey-type communication activity. II-1, p.6.
Picture talk. Getting students talking about a picture. II-5, p. 1.
Reviewing children's books with adults. A discussion activity. II-3, p.7.
See also: **Cultural activities and Reading.**

Hints & tips

- 'How-to' lesson by students. II-2, p.9.
Party games. II-4, p.10.
Picture stories for conversation. II-3, p.8.
Poker faced definitions. II-6, p. 10.
Proverbs. II-3, p.8.
Retelling a folktale. II-3, p.8.
Scrabble-crossword. II-1, p.9.
Sharing folktales. II-3, p.8.
Telephone technology. II-2, p.9.
'Try to speak English' button. II-5, p.10.
Vocabulary jigsaw puzzles. II-6, p. 10.

Humor

- Talking about testing. . . (a lighter look at ESL placement testing). II-1, p.8.

Minigrants program

- About the Minigrants. II-5, p.6.
Awardees for 1992 named. II-2, p.10.
Reports from Minigrants award winners: II-5, p.4-5, and II-6, p.8.

Puzzles

- A dictionary puzzle. Helping students to become familiar with the features of a dictionary. II-2, p.2.
Election issues. Multi-level crossword puzzle about the U.S. elections in '92.
A summer picnic. A puzzle about the multicultural background of our common foods. II-1, p. 2.
Parts of the body. Multi-level crossword puzzle. II-6, p.6.
World news geography. A crossword puzzle relating current events to the world map. II-4, p.2.

Reading

- Family reading time. Report on a family literacy project. II-5, p.4.
See also: **Group activities**

Reviews: On the market

- All about English as a Second Language—A Basic Guide to ESL and Bilingual Education*. A list of resources. II-1, p.10.
BESTEL and CELSA. ESL placement tests. II-1, p.1.
Crossroads, Book 1 and 2. Basic text for beginners. II-2, p.12.
A Picture is Worth 1000 Words. Photos for discussion. II-5, p. 1.
Stories We Brought With Us. Beginning readings for ESL. II-3, p.9.
Tales from Around the World. Stories for Whole Language Learning. II-3, p.9.

Tools & techniques for instructors

- Gadgets, widgets, doohickeys and gizmos. Devices that make teaching easier. II-6, p.4.
Lesson planning—after the fact. II-6, p. 1.
Please speak English! II-4, p.1.
Why folktales? II-3, p.1.

Writing

- The Class Journal. A notebook which circulates from student to student. II-5, p.8.
ESL Yearbook Project. Students produce a class yearbook. II-5, p.5.
Penpals in class. Students write letters to each other. II-2, p.8.
See also: **Group activities.**



Hints & tips

Have you got an idea that works for you? Why not share it with other readers? ESL teachers and tutors are always looking for ideas to try out with their students.

More encouragement

Marcia Hannett writes that she enlarged the "Try to speak English" button on page 10 of our January/February issue and made two signs to post in her refugee class. Seems like a good idea. (Now, how about a 10-foot banner??)

Poker faced definitions

Here's a fun way for advanced learners to increase their vocabulary, sent to us by Barbara Cogburn of Haywood Community College in Clyde, North Carolina.

First, explain the term 'poker face' (it's the expressionless face of a poker player trying to conceal the nature of his hand). Next, introduce a topic (*sounds*, for example) for which you have some new vocabulary items written on slips of paper. For example, *sounds* vocabulary might include: muffled, ear-splitting, shrill, raspy, etc.

Give each student one of the slips and ask them to write a definition of the new word. The definition may be true, or it may be ridiculous. Then the students read their definitions aloud, but without laughing (poker-faced). The other students will try to guess whether they are bluffing, or giving the actual meanings.

Vocabulary jigsaw puzzles

Joyce Seversky, lead ESL teacher at OCM BOCES, Liverpool, New York, sent us this suggestion.

Blank jigsaw puzzles come in various sizes and colors and can be used to reinforce new vocabulary. You can write words on the pieces, or paste small pictures on them. I have designed puzzles with synonyms, antonyms and two-word verbs. The matching words go next to each other on the puzzle, so a student must know which two words go together to solve the puzzle. Students can make their own puzzle, too.

Blank puzzles, called "COMPOZ-a-Puzzle" can be ordered through J.L. Hammett Co., One Paliotti Parkway, Lyons, NY 14489. ↵

Letters

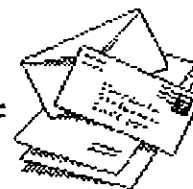

Where's that book?

The latest issue of *Hands-on English* reviewed "A Picture is Worth 1,000 Words" by Anthony Mollica. Can you please send me the name and address of the publisher? Thank you.

- Mary Lu Landgren
Chicago, IL

We lost count of how many people wrote or called about this book. Sorry, folks—we goofed! The publisher, éditions SOLEIL publishing, inc., is located in Ontario, Canada.

In Canada, write: P.O. Box 847, Welland, Ontario, L3C 4X8.

In the U.S., write: P.O. Box 890, Lewiston, NY 14092-0890.

Phone or fax: (416) 788-2674.

New culture

I am very confident teaching Hispanics as I know the language and culture. But the Chinese are a challenge for me. Are there any techniques for teaching ESL to the Chinese?

- Donald Korsun
New York, NY

We'd welcome some input from our readers on this one. Does anybody have some experiences to share? Some hints about the culture that might help?

Classroom dilemma

What can a teacher do with a student who talks too much?
- Paulette Bork
Mechanicsburg, PA

This can be a very uncomfortable situation. We have a couple of ideas: Have the students work in small groups so that the problem is less disruptive to the whole class. And try giving the student some extra attention outside of class. Any other ideas from our readers?

Tutors, too

Not all of us are working with groups or classes—could you have more suggestions for one-on-one situations?

- Corinne Moran
Oak Bluffs, MA

Several readers have mentioned this, and we'll certainly try to include more activities specific to individual tutoring. Many of the 'classroom' activities you see can be adapted for one student, so we'll try to be more helpful in suggesting how this can be done. ↵

EDUCATIONAL SHOWCASE

Your ESL Connection

Providing ESL/EFL Programs for All Ages

The Largest Collection of ESL Materials
on Display in the Midwest

- * Place orders by mail or fax: (313) 680-1052
- * UPS delivery in 5 to 10 days of in-stock items
- * We meet publisher's prices AND beat the service
- * To order or to receive our comprehensive ESL catalog write to:



EDUCATIONAL
SHOWCASE
1334 Wheaton Street
Troy, MI 48083
(313) 680-0860

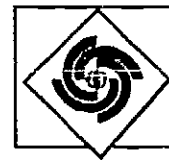

Intercultural PRESS

Your direct source for books, videotapes,
and training materials on intercultural
relations, cross-cultural adaptation,
diversity and multicultural education.

Call or write to receive a free copy of our
latest catalog.

P.O. Box 700 • Yarmouth, ME 04096
(207) 846-5168 • Fax (207) 846-5181
1-800-370-BOOK (in the U.S.)

Classified ads

Your ad goes here

Our "classified" section gives you a chance to network with people and find out about products & services of interest to you.

Classifieds can include notices about schools, courses offered, publications, new products, special offers or requests from our readers.

To place a classified ad, send your notice of 30 words or less with US \$10 (or if you are a subscriber, take a DISCOUNT of 50%) to:

Hands-on English
P.O. Box 589
Dewitt, NY 13214 USA

Our phone/fax number is (315) 445-0785.

Publications

American Holidays. Exploring Traditions, Customs, and Backgrounds. 17 readings each with 5-6 varied vocabulary exercises. Plus holiday readings, songs, national holidays of all other nations. \$9.50. *Pro Lingua Associates.* (800) 366-4775.

Back issues of *Hands-on English* are now available at US \$4 per copy (this includes shipping costs). Let us know which issues you're missing! See our address above. ➡

News & notes



Upcoming conferences

If you need more information about any of these conferences, call *Hands-on* at (315) 445-0785.

- ◆ May 2-4, 1993—New Jersey Association for Lifelong Learning (NJALL), spring conference at the Ocean Place Hilton in Long Branch, NJ.
- ◆ May 5-7, 1993—Tennessee TESOL, Murfreesboro, TN. Contact: Anna Hustedde, tel. (615) 243-7019.
- ◆ May 22-25, 1993—National Multicultural Institute (NMCI), annual conference in Washington, DC. Contact: NMCI, tel. (202) 483-0700.
- ◆ June 2-5, 1993—International Association for Learning Laboratories (IALL), annual conference in Lawrence, Kansas. Contact: John Huy, Kansas University, tel. (913) 864-4759.
- ◆ July 2-4, 1993—Global Awareness Society Int'l, Comparative Linguistics section, annual meeting in New York, NY.

Photo opportunities

The Polaroid Education Program (PEP), offers a Visual Learning Teacher Workshop to school teachers throughout the U.S. These workshops provide practical ideas for using photos in the classroom. Participants in the program also receive a newsletter called "PEP Talk" that includes lots of teaching ideas.

To participate in the program, write or call PEP, 565 Technology Square—3B, Cambridge, MA 02139, tel. (617) 577-5090.

Renewals

We send your *Hands-on English* renewal notice with your final issue, so please renew promptly to avoid missing an issue.

Unlike many publications, we don't start writing to you eight months ahead of time! And we don't send everybody a million notices!

If you like, you can save paper and hassle by renewing early. Just send us the form on page 2, marked "Renewal," with your payment. The mailing label on your next issue will indicate the new expiration date. Thanks! 🐾



A periodical for teachers and tutors of adult ESL
 P.O. Box 589
 Dewitt, NY 13214
 USA

ADDRESS CORRECTION REQUESTED

March/April issue

149



Hands-on English

A periodical for teachers and tutors of adult English as a second language

Editorial: Photocopy fever

"Think, think, think"

One of the most tiresome, tedious and trying aspects of teaching in adult ESL programs is the massive amount of photocopying that seems to be necessary to do a good job. There are several reasons why the "think, think, think" of a copy machine is the sound of an ESL teacher preparing for class:

Good Reason #1—Many of our adult programs are underfunded and don't have enough books or materials for the students.

Good Reason #2—Unlike college students, our students usually can't be expected to purchase their own books for financial reasons. In some programs there is even a policy discouraging this.

Good Reason #3—Even if our program does have books and materials to work with, they are *never* sufficient for the varied and changing needs of our students. Supplementing and expanding is an everyday part of good teaching.

Good Reason #4—Language learning takes lots of paper input, so the students have something to take home with them.

Problems with paper

You are probably already aware of the problems with so much photocopying:

Problem #1—It is not always legal (even if everybody does do it).

Problem #2—It's confusing for the students who are flooded with papers. A language course based on photocopies often lacks continuity.

Problem #3—It's a waste of the instructor's time, not to mention resources.

Six ways to reduce "handouts"

Here are some ideas to help you reduce the amount of photocopying you have to do, yet still do an effective job.

- 1—Use an overhead projector for some activities. Students can copy down the portions they need to remember.
- 2—Use dictation when possible to convey information to the students. This may be slow, but it is valuable practice for them.
- 3—Use large sheets of newsprint for short passages. These can be posted on the wall for several sessions, and rolled up for transporting.
- 4—Use a 'flip chart' style pad to display new vocabulary during a session. This makes it easy to go back and review.
- 5—Make a handout as memorable as possible. Use it for as many different activities as you can think of. Refer to it again in another session.
- 6—Encourage your students to use a 3-ring binder to organize their papers. ➔

Contents:

Crossword puzzle:	
- "Team sports".....	2
Grammar grab-bag:	
- Tense review.....	4
Idea file:	
- Round robin stories.....	5
Hints & tips.....	5
Minigrants award winner:	
- Books in a migrant camp.....	6
Tools & techniques:	
- Where to get ESL materials.....	8
On the market:	
- Reviews of two reading texts.....	9
Tutors, too.....	12

Hands-on English (ISSN 1056-2680) is published six times a year (Jan./Feb., March/April, May/June, July/Aug., Sept./Oct., Nov./Dec) by Hands-on English, P.O. Box 589, Dewitt, NY 13214 USA.

Copyright © 1993 Hands-on English

Subscription rates:

\$16 regular rate for individual subscribers, \$10 (discounted rate) for volunteers or teacher's aides, \$22 (multi-user rate) for libraries or institutions. Single copies are \$4 each. **Postage & handling:** Canada and Mexico add \$4; outside N. America add \$10.

Permission to photocopy: This periodical is copyrighted. However, we invite teachers and tutors who have a paid subscription (or whose institution has a paid subscription) to make as many copies as they need for their own classroom use.

Please don't make copies for colleagues! We survive on the subscriptions of our readers.

Editor: Anna Silliman
(M.A Teachers College, Columbia Univ.)
Consulting Editor: Karen Campbell
Cartoonist: Michael Capurso

Address correspondence to the editor, *Hands-on English*, P.O. Box 589, Dewitt, NY 13214 USA. Phone/fax (315) 445-0785.

Subscribe today!

Send this form with your check or money order (U.S. funds only) to the above address.

Please send me a subscription to *Hands-on English* for one year (6 issues). I enclose:

- \$16 for a regular subscription
- \$10 discounted rate for a volunteer or aide
- \$22 multi-user rate for a library/institution
- _____ postage/handling: Canada/Mexico add \$4.
Countries outside N. America add \$10.

Name: _____

Address: _____

Institution: _____

Position: _____

Check here if this is a **renewal**. III-1 2

Crossword puzzle: Team sports

Here's a puzzle that your students can do just for fun, or that you could incorporate into a cultural unit on sports.

Even if you're not a sports fan yourself, keep in mind that knowing something about sports in this country, or participating in them, gives your students a rare opportunity to interact with the people here on common ground. Sports can lower social barriers.

Conversation

Ask students to tell about what kinds of sports they like to participate in, and what kinds of sports are popular in their country. (For more tips on getting a sports discussion going, see *Hands-on English*, Vol. II, No.2, page 5.

Presentation

Have students describe a sport to the group. Give them some time to prepare this, and have some pictures available for the presenters to use.

Sports news

For more advanced students, read an article in the newspaper about a sport they are interested in. This could be a report on a game, or a controversial issue regarding team sports.

If you are discussing a big game in class, keep in mind that lower-level students can participate, because if they are interested in sports they can follow a game on TV perfectly well even without English skills. This "knowledge" gives them a chance to participate in the discussion and maybe even inform the rest of the group about something the others didn't know.

Reading

Sports heroes make popular reading. Look for biographies of athletes at an appropriate level for your students, and offer them as optional reading. ←

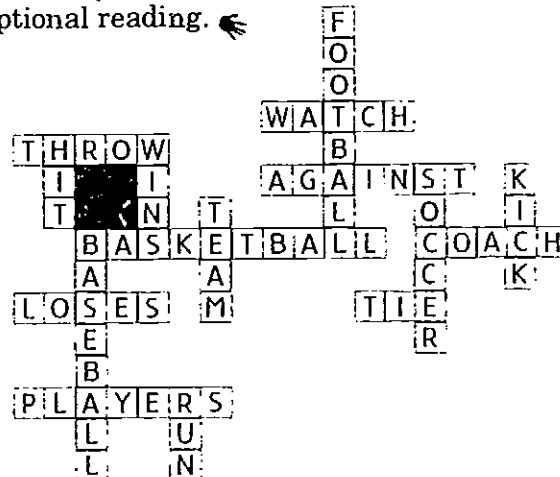

Crossword puzzle: Team sports

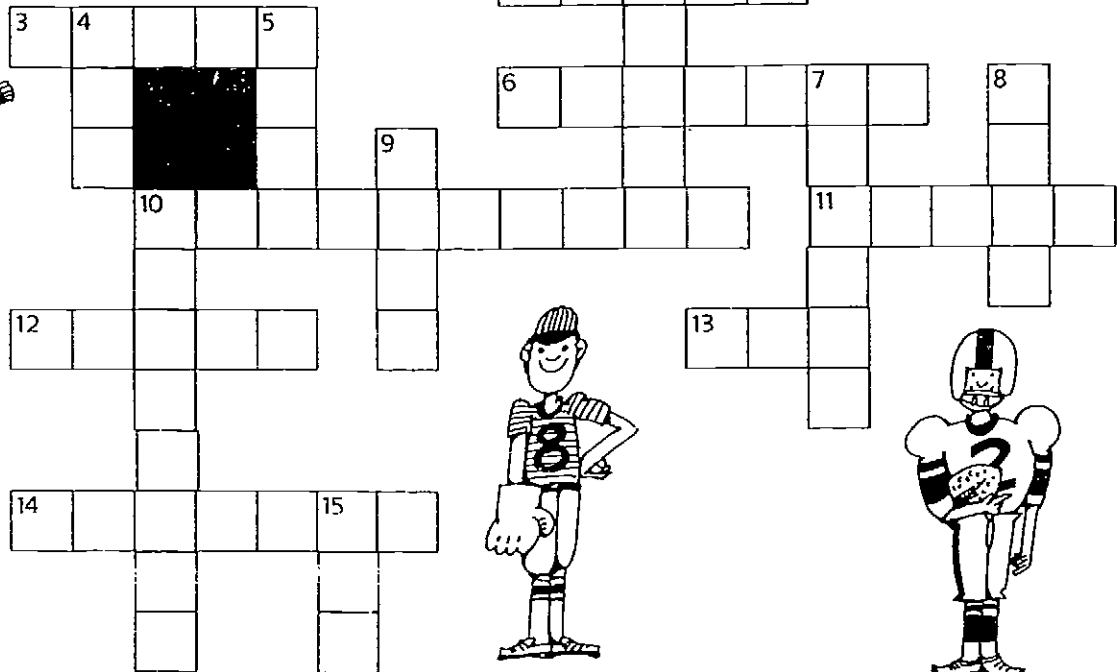
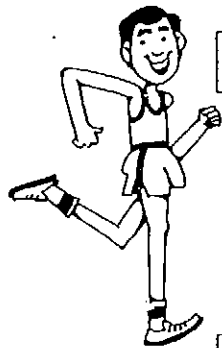

Across clues

2. Many people don't play sports, but they like to _____ them on TV.
3. In basketball, you try to _____ the ball through the hoop.
6. In the fall and winter, you can see many _____ games.
10. _____ is a game usually played indoors.
11. The person who tries to show the players how to play better is the _____.
12. At the end of a game, the team with fewer points _____ the game.
13. If both teams have the same number of points at the end of the game, the game is a _____.
14. The people who play in a sporting event are the _____.

Down clues

1. In the fall and winter, you can see many _____ games.
4. In baseball, you try to _____ the ball with a bat.
5. At the end of the game, the team with the most points _____ the game.
7. In this sport, the players don't touch the ball with their hands.
8. In soccer, you try to _____ the ball across the goal line.
9. A group of players who are on the same side is called a _____.
10. In the spring and summer, you can see many _____ games.
15. In football, you try to _____ with the ball across the goal line.

Grammar



"I'm going away next week."

Tense review

Here's an informal conversation activity that will give your students a chance to review present, past and future forms and phrases, while talking about themselves and their plans.

How to do it

Give each student a copy of the page below. This activity works best in pairs, so have them choose a partner.

Ask the students to look at the calendars and talk about their life and plans. They can use some of the suggested time words as starters. Each student may take 5 or 10 minutes to do this; if they talk longer, that's great.

For additional practice, students could change partners and repeat the exercise.

Radar ears

The instructor should quietly circulate and listen for problems. When you hear something wrong, just write the correct form on the board and point it out to the student.

Write and read

If there is time for writing, have the students write a paragraph or two entitled "My plans." The following session you could present one or two of these to the rest of the class for reading. Do this on the overhead projector if it's just for fun. If you're making a worksheet from the student's writing (for example leaving blanks for the verbs to be filled in), then make copies and hand them out.

Make a game

A variation of this activity is to use the calendar as a board game. Students throw dice and move a marker to land on one of the days. They then have to say something about themselves, relative to that time. For example, "Yesterday was not my birthday," or "Last month I got a new job."

To use this page as a board game, you may want to enlarge it first. Or, use a desk-sized calendar instead. ➡

May						
						1
2	3	4	5	6	7	8
9	10	11	12	13	14	15
16	17	18	19	20	21	22
23	24	25	26	27	28	29
30	31					

June						
		1	2	3	4	5
6	7	8	9	10	11	12
13	14	15	16	17	18	19
20	21	22	23	24	25	26
27	28	29	30			

July						
				1	2	3
4	5	6	7	8	9	10
11	12	13	14	15	16	17
18	19	20	21	22	23	24
25	26	27	28	29	30	31

PAST:

yesterday
the day before yesterday
last week
two weeks ago
last month

PRESENT:

today
this week
this month

FUTURE:

tomorrow
the day after tomorrow
next week
the week after next
next month



Here's an activity for your file of 'emergency' ideas. Cut out the card below and tape it to a 4x6 card. Keep it handy in case you need an activity on short notice.

'Round robin' stories

Purpose: Reading and writing practice; teamwork.
Level: Adaptable. Also works with multi-level groups.
Time: 30 - 60 minutes, depending on how much the students write.
Materials: Blank paper. Topic sentences/pictures for story starters, if needed

1. Divide the class into groups of 4 or 5. Have each group sit together around a table, if possible.
2. Tell the group that they will be writing some stories together.
3. Give each student a blank sheet of paper.
4. Start the stories—**Advanced students:** Have each student think of something they would like to write about, and then write the first sentence only on the paper. **Intermediate students:** Prepare in advance some topic sentences and put each one on a card. Let each student choose one and write it on their paper. **Beginning students:** Provide some interesting pictures for the students to choose from. Have each student write one sentence about a picture.
5. Pass the papers to the left and have each student write the second sentence of the new story. Continue until the students decide the stories are finished.
6. Have the students in the group read the stories aloud and choose the best one. (They can write some more, if they want to.) Then read that story aloud to the rest of the class.

Hints & tips

Idiom-of-the-week

Idioms are hard to learn, especially for beginning and intermediate students. Some books and materials are available to teach idioms, but they often present too much material at once and the students can't absorb it or incorporate the idioms into their speech.

One idea we have had is to start presenting idioms early—even to beginners—but just one at a time. An idiom a week is probably plenty.

An example

Choose a group of idioms that are very common and that originate from a similar source. For example, some idioms we use frequently that originate in sports and games include: Take a turn. Keep the ball rolling. Play hardball. Stay on the ball. The ball is in your court. (And many more.)

At the beginning of the week, write one of these idioms on the board (or on a large sheet of newsprint) and explain to the students what it means and where it comes from. Then give several examples of how we use this idiom, in different contexts.

Keep this idiom posted in front of the room all week. If it's appropriate, use the idiom when talking to the students. For example: "Maria, you're next—let's keep the ball rolling." Some students may want to include this idiom in their speaking and writing that week.

One warning—be sure to choose an idiom that is easy enough for the students to learn, and that they can use correctly. Learning an idiom is no help if it's not used correctly.

Next week, choose another idiom from the same group and focus on that one. ↩

☆ Minigrants '92 award winner: "Books-in-Camp"

by Patricia Edwards of the BOCES Geneseo Migrant Center in Geneseo, New York. Pat used her grant to create a mini-lending library for families in two migrant worker camps. A Title VII Bilingual Grant (Migrant Family English Literacy) also supported the project.

Need for books

Migrant families have little or no access to environmental print. Yet, it is clear that to migrant families a book is a treasure. Migrant students in ESL classes request their own texts and workbooks and proudly carry them as evidence of their involvement in education.

The "Books-in-Camp" book lending project provided English, Spanish and bilingual books to migrant families in their camps. It was developed to overcome the lack of books in migrant homes/camps and enhance the English-speaking ability of migrant adults through involvement in intergenerational literacy activities. It was also intended that the project would acquaint the families with the concept of borrowing books and, hopefully, library usage.

Library in a box

"Books-in-Camp" was implemented by creating two small collections of culture, language and gender appropriate books. Most of the books were children's literature, although adult English/Spanish dictionaries were included. The books were prepared with library pockets and cards. About 30 books were packed in a "banker's" storage box which also included parents' packets with bilingual information on reading to children and an introduction to the library.

The "Books-in-Camp" boxes were transported once a week for 5 weeks to the migrant camps where parents selected and signed out books. Parents were asked to return the books in one week. ESL instructors assisted in the borrowing process and modeled reading to children.

Project results

"Books-in-Camp" was an instant success, with parents crowding the instructor to sign out books. Instructors reported that bilingual books were the most popular. They also noted that the students compared and discussed the English and Spanish stories among themselves. One of the students even questioned the instructor about differences in

sentence structure and verb placement upon seeing the two languages side by side.

Surprisingly, the most popular book was *The Cat in the Hat Bilingual Dictionary* by Dr. Seuss. It appears that the playful descriptions and the wacky illustrations and humor were irresistible even to adults. In addition, the biography of a Hispanic baseball player provoked interest and discussion with the adult male students. Most of the books were written at a 3rd to 5th grade level, yet the readability and interest level seemed to overcome the juvenile aspect and the adults were quite comfortable with them. When questioned, parents even indicated that they were reading books to their children (although the project did not document this).

"The participants were migrant farmworker adults involved in ESL instruction at migrant camps where they lived. The two pilot groups were a pool of 7 book borrowers in one camp, and a pool of 13 in another. Most of the students were non-English speakers, and all were parents."

Will it work?

When "Books-in-Camp" was introduced to the instructors, there was some skepticism as to whether the borrowing concept would work. Yes, several books have been "lost" ...or not returned. But we believe that the cost of several books is a small price to pay when the books are in the hands of a family that otherwise would be without.

As a pilot project, there was speculation about the practicality of the process. Would toting the box from camp to camp be worth it? After trying it, the instructors concurred that "Books-in-Camp" was a definite asset and provided an additional dimension to their instruction.

Back by popular request

The project provided us with the opportunity to explore the use of the traditional bookmobile concept for ESL and family literacy. The success of the concept was illustrated this spring when upon arriving back in the area, parents requested the 'book boxes.' The "Books-in-Camp" lending library will be in place again this year. ↵

Letters



Good timing

"My Taiwanese student requested information about American death and funeral customs just one week after your issue containing such a lesson arrived (Vol. II, No. 5). The stick figure drawings were especially helpful. I was able to expand on the outline you gave. My student was interested, grateful and the next week asked pertinent questions. Thank you.

-Elizabeth Gulino
Hasbrouck Heights, New Jersey

The muse strikes

The renewal notices we sent out recently contained an inspirational poem (which we were rather proud of). Several readers sent us poems in response! Here's one:

"Unlike others we know
Your publication is not just so-so.
It has information we can use
And believe us, that is news!
Please keep the ideas flowing
And your letter we'll keep on knowing."

-Kay Enborn
Crossroads English School
Corvallis, Oregon

Sticky stuff

"With regard to the article 'Gadgets, widgets...' in the March/April 1993 issue, clear 'Mac Tac' on a roll is also an inexpensive method of laminating since the size is no object."

-Diana Kohl
Victoria, British Columbia, Canada

We haven't seen this product before. Does anybody know where to get it in the States?
-Editor

About the Hands-on English Minigrants



Our Minigrants program awards small grants to teachers or tutors of ESL for the development of an instructional project, to benefit their students.

Last year we awarded five \$100 grants (you can read about one of these on page 6 of this issue). This year we will be awarding ten grants. The awardees will be announced in the July/August issue.

Applications for the 1994 grants will be due April 30, 1994. Write to the *Hands-on English* office for more information. ↵

Nightschool



Tools & techniques:

Where to get ESL materials

Getting your hands on ESL teaching materials is sometimes a bit tricky. If you are new to the field, you may not know where to start looking. Even if you've been around for a while, though, finding materials can be frustrating because publishing companies seem to change hands frequently. And aside from the really well-known publishers, there are numerous small companies that put out interesting new materials—how do you even find out about these?

ESL is not junk

The first thing to do is get on some mailing lists and acquire some junk mail. Major publishers send out catalogs once or twice a year, and sometimes also send notices about new books. You can write and request to be included on their ESL mailing lists. Start with:

1. Addison-Wesley (includes Longman titles)—ESL Publishing Group, 10 Bank Street, White Plains, NY 10606-1951.
2. Heinle & Heinle (includes Newbury House titles)—20 Park Plaza, Boston, MA 02116 USA.
3. Oxford University Press, ESL Department, 200 Madison Ave., New York, NY 10016 USA.
4. Regents/Prentice Hall (includes Alemany Press titles)—ESL Marketing Dept., Englewood Cliffs, NJ 07632 USA.

Medium & little guys, too

Useful materials don't only come from big publishers (*Hands-on English* is a good example!), so you'll want to get catalogs from Dominie Press, Pro Lingua Associates, Audio-Forum, International Linguistics Corporation, American English Publications, Linmore Publishing, Full-Blast Productions and others

To find out about small publishers, attend a regional ESL teachers' conference or adult education conference. Sometimes you can get into the publisher's exhibit without paying the entire conference fee—larger conferences will sell exhibit passes. If you are a volunteer tutor or a student, be sure to ask if there is a conference discount for you.

Be a pro

If you join a professional organization, you'll get newsletters that often carry descriptions and reviews of new materials. The international organization for ESL teachers is: TESOL, 1600 Cameron Street, #300, Alexandria, VA 22314-2751 USA. Tel: (703) 836-0774. TESOL also has smaller, regional organizations you can join in both Canada and the U.S.

Literacy organizations are extremely important to our adult ESL students, and they provide useful materials and training. For a Literacy Volunteers of America catalog write: LVA, 5795 Widewaters Parkway, Syracuse, NY 13214-1846 USA. Tel: (315) 445-8000.

To find out about adult education organizations, contact your state education office, adult education division.

Distributors

When it comes to actually sending for a book, this editor has found that ordering directly from the publisher is not always the fastest way to get it, particularly when ordering from the larger publishers. 'Distributors,' who handle ESL materials from many different publishers, specialize in shipping you materials quickly—sometimes in a day or two. They also print catalogs which can be a useful resource of information about available ESL materials.

Keep in mind that distributors do not carry everything, and that different distributors carry different books. To find a particular book, you may need to shop around a bit. 🐾

Here's a handy card to add to your Rolodex file. Happy hunting!

ESL distributors

Alta Book Center
14 Adrian Court
Burlingame, CA 94010
Tel: (800) ALTA/ESL
Fax: (415) 692-4654

Educational Showcase
1334 Wheaton St.
Troy, MI 48083
Tel: (313) 680-0860
Fax: (313) 680-1052

Delta Systems Co., Inc.
1400 Miller Parkway
McHenry, IL 60050-7030
Tel: (800) 323-8270
Fax: (815) 363-2948

On the market

Reviews of useful ESL materials

"Stories from the Heart" by Ronna Magy (1991, Linmore Publishing, Box 1545, Palatine, IL 60078 USA). ISBN 0-916591-26-3. \$6.95.

Very often, stories that are easy enough for your beginning level students to read are boring or condescending in content. Here's a collection of student-written stories that is mature, interesting, upbeat and realistic in content, but is still simple enough in language structure for high-beginning and low intermediate students to understand.

The 31 stories provide lots of reading material. They are divided into six topics (such as "Early Memories" and "An Important Person") that cover a range of newcomer's experiences and emotions, and that could lead you and your students into discussions of important issues.

For example, one story is about a fishing trip. The author didn't realize he needed a fishing license, which led to a misunderstanding with a policeman. Your students may be interested in the issues this story brings up—such as cultural differences, bureaucratic regulations, and accepted norms of behavior in dealing with police.

Each story also provides practice in all four language skills: reading the stories, writing the exercises and student compositions, speaking in cooperative and pair activities, and listening in the guided imagery activities that are suggested for each unit. The vocabulary is sometimes more advanced than you would expect, but this is a plus as it is real-life vocabulary your students will want to know.

Instructors working with multi-level groups will find the book adaptable for this purpose. For example, more advanced students could be expected to do more writing in response to the stories. And the stories could certainly be used as springboards for discussion at almost any level.

For a more extended writing project, the students could use the units in this book as a model for their own class book. They could choose a topic, which then each student would write about, forming a collection of stories on one idea. This would work well with a multi-level class as each student is contributing at his or her own level.

This is an accessible, user-friendly book that I can highly recommend.

--Karen Campbell 9

"Insights for Today: A High-Beginning Reading Skills Text" by Lorraine C. Smith and Nancy Nici Mare (1993, Heinle & Heinle Publishers). ISBN 0-8384-3978-0. \$15.

Here is another excellent reading text, for a slightly different kind of student. Whereas *Stories from the Heart* (see review, left) is suitable for a general audience, this book is probably intended for a student with at least some educational background—say, an 8th or 9th grade education in their own country. It could perhaps be considered 'pre-academic' in nature.

The 12 reading passages are well-written, interesting, and will certainly stimulate discussion. The topics are timely, adult and fun. They include such science topics as "The Extinction of the Dinosaurs," health topics such as "Secondhand Smoke" and social topics such as "Twins: How Alike Are They?"

The authors have really succeeded at presenting sophisticated topics at a high-beginning level; something that sets this book apart from many others. The readings, about a page and a half in length each, make use of repetition and rephrasing, which helps students to read unfamiliar material. Also, the pre-reading discussion questions will help them learn new vocabulary and prepare to read.

There are plenty of exercises with each story, including comprehension questions, cloze passages, vocabulary exercises, crosswords, and discussion and writing topics. For lower-level students these will come in useful. For slightly more advanced students they would be too repetitious, so you will probably want to pick and choose the activities most suitable for your students.

Listening activities are not included in the book as it is intended to be a reader (not a core text). The book is the first in a series of four readers by the same authors, two of which will be published next year.

The most enjoyable aspect of this book for my students was the interesting discussions we had. When the budget allows, I will certainly order this book for my class.

--Karen Campbell



Hands-on English, Vol. III, No. 1

News & notes



Upcoming conferences

- ♦ June 28-July 30, 1993—TESOL Summer Institute. San Bernardino, CA. Contact TESOL, (703)836-0774.
- ♦ July 2-4, 1993—Global Awareness Society Int'l, Comparative Linguistics section, annual meeting in New York, NY.
- ♦ July 20-24, 1993—Linguistic Association of Canada and the U.S. (LACUS). 20th annual forum, Univ. of Illinois at Chicago. Contact: Ruth Brend, (313) 665-2787.
- ♦ August 13-14, 1993—American Association of Education in Private Practice (AAEPP) conference in Madison, Wisconsin. Contact: Chris Yelich, N7425 Switzke Rd., Watertown, WI 53094.

Not only English in Florida

A Dade County "English only" ordinance enacted 13 years ago was repealed this May. The ordinance, which had made English the only language legally used by government agencies was apparently never workable in an area where two languages is the reality.

Dade County includes the city of Miami, and the population is about 50% Hispanic. The decision was a symbolic victory for opponents of the English Only movement.

Send teacher's tales

Author Ray Clark is putting together an anthology about the profession of ESL (to be published by Pro Lingua Associates). He is interested in creative input from teachers— anecdotes, personal experiences, humor, parody, cartoons, poems, short stories.

Send your typed contributions to: Ray Clark, World Learning Inc., MAT Program, P.O. Box 676, Brattleboro, VT 05302.

Hey! Don't forget us!

Hands-on English welcomes freelance articles of (500 to 1,000 words) of interest to instructors and tutors of adult ESL. A sheet of guidelines is available upon request.

We also welcome input on an informal basis—letters, postcards, faxes, phone calls, telegrams and smoke signals are eagerly received. We want to be your network. ✉

Classified ads

Your ad goes here

Our "classified" section gives you a chance to network with people and find out about products & services of interest to you.

Classifieds can include notices about schools, courses offered, publications, new products, and special offers or requests from our readers.

To place a classified ad, send your notice of 30 words or less with US \$10 (or if you are a subscriber, take a DISCOUNT of 50%) to:

Hands-on English

P.O. Box 589

Dewitt, NY 13214 USA

Our phone/fax number is (315) 445-0785.

Publications:

Conversation Inspirations. Over 1200 conversation topics. 6 activity techniques: interviews, talks, role plays, problems, chain stories, discussions. A quick, easy resource for any language class. \$9.95. *Pro Lingua Associates.* (800) 366-4775.

Now available—THE ESL LOCATOR: Sal Parlato's updated guide to 1,200 national ESL organizations. Prepaid \$11.50 (includes S&H) from TESOL, Booklink, or from: Dolores Parlato, 248 Seville Drive, Rochester NY 14617.

Back issues of *Hands-on English* are now available at US \$4 per copy (this includes shipping costs). Let us know which issues you're missing! See our address above.

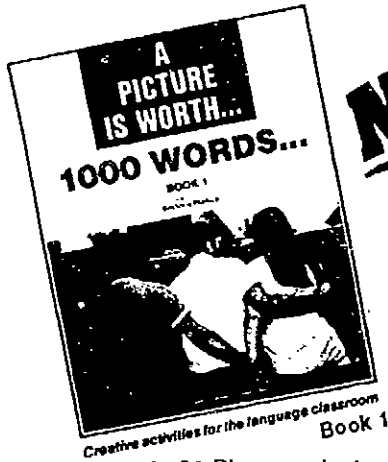

NEW!

by
Anthony Mollica

includes Teacher's Guide to
A picture is worth... 1000 words...

by
**Anthony Mollica
Julie Ashcroft
Anne-Marie Finger**

\$24.95 each Add \$4.00
for Shipping

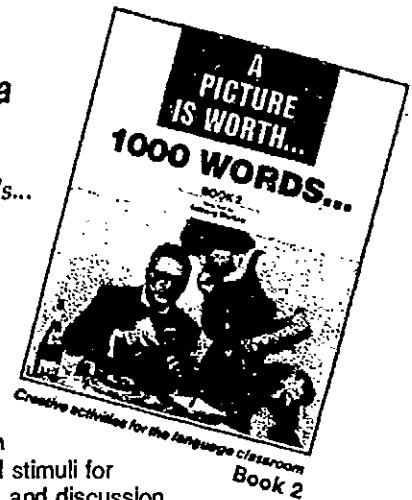

Creative activities for the language classroom
Book 1

Creative activities for the language classroom
Book 2

- Detachable Line-Masters for Reproduction
- ✓ 60 Photographs by North American photographers
 - ✓ Each photograph may be photocopied for classroom use
 - ✓ Excellent visual stimuli for comprehension and discussion
 - ✓ Suitable for different grade level and multi-level classes

The Guide provides a series of questions to stimulate the students'
 ✓ visual comprehension ✓ personal interpretation ✓ creativity
 at three linguistic levels

✓ beginning ✓ intermediate ✓ advanced

A Teacher's Guide is available in
 English French German Italian Spanish
 (Please specify language.)

éditions SOLEIL publishing inc.

P.O. Box 890 • Lewiston, New York 14092-0890 • Tel./Fax (416) 788-2674



Intercultural
PRESS

Your direct source for books, videotapes, and training materials on intercultural relations, cross-cultural adaptation, diversity and multicultural education.

Call or write to receive a free copy of our latest catalog.

P.O. Box 700 • Yarmouth, ME 04096
 (207) 846-5168 • Fax (207) 846-5181
 1-800-370-BOOK (in the U.S.)

EDUCATIONAL SHOWCASE

Your ESL Connection

Providing ESL/EFL Programs for All Ages

The Largest Collection of ESL Materials
on Display in the Midwest

- * Place orders by mail or fax: (313) 680-1052
- * UPS delivery in 5 to 10 days of in-stock items
- * We meet publisher's prices AND beat the service
- * To order or to receive our comprehensive ESL catalog write to:



EDUCATIONAL
SHOWCASE
1334 Wheaton Street
Troy, MI 48083
(313) 680-0860

Tutors, too

Karen Curlee, Tutorial Services Coordinator at Rio Hondo College in Whittier, California, shares with us some thoughts on tutoring ESL students. Her suggestions are particularly useful for students who are working on their writing.

1. Let them correct it

Remember that in a tutor-tutee relationship, the pencil should always be in the tutee's hand. If tutors mark up or correct their tutee's papers, very little learning will occur for the tutee. The tutee should be an active participant.

2. Have them start it

If an ESL student has a writing assignment to complete, the student should have engaged in some pre-writing activities and completed a rough draft first, *before* seeing a tutor. The tutor may become too much of a crutch if the process is reversed.

3. Proofreading aloud

When working on a written assignment, have the ESL student read aloud what he or she has written. This is an opportunity for the student to proofread at the same time. All

students, ESL or not, tend to rush through their work without rereading what they have written, so tutors should teach them the value of proofreading.

4. Don't ask—discuss

Refrain from using the 'Socratic' method of questioning—that is, asking questions of the tutee from simple to complex. The answers to this type of question are simply either right or wrong, and ESL students may be intimidated by this approach. Also, using this method you are doing their thinking for them.

A more successful approach is to use an 'informational' strategy, such as a demonstration-application approach. First you demonstrate or give examples of a concept; then ask the student to apply this information in a different context.

This approach, rather than the Socratic one, reflects a broader range of the student's own thinking and provides more food for discussion. The tutorial relationship becomes a team effort and is more enjoyable for both parties involved. ↩



A periodical for teachers and tutors of adult ESL

P.O. Box 589
Dewitt, NY 13214
USA

ADDRESS CORRECTION REQUESTED

May/June issue

181



Hands-on English

A periodical for teachers and tutors of adult English as a second language

This year's Minigrants awards

This summer *Hands-on English* awarded ten Minigrants of \$100 each to teachers and tutors who applied for a grant. We're especially proud of this year's award winners, who we think all have worthwhile ideas that deserve to be supported. We look forward to reporting on these classroom projects over the next few months! This year's winners included:

Alyce di Palma, a teacher at the Alameda Adult School in Alameda, California. Her students will produce a publication of international recipes. They will gather the information for the book from interviews.

Barbara Fish in Salt Lake City, Utah. Barbara tutors 10 students for the Literacy Volunteers of America (LVA) Wasatch Front. Her project, called "Elders of the World Cookbook," will bring senior citizens together to discuss and prepare ethnic foods from their native lands. The project will include written stories from each participant.

Joyce Grane, who teaches refugees at the YWCA in Tulsa, Oklahoma. Her students will run a pizza restaurant with cooks, waiters, waitresses, and customers. They will decide on ingredients, menu and costs for the food, then actually prepare, cook and serve it.

Barbara M. Grant, who teaches immigrants and refugees at the Indian Valley Opportunity Committee (IVOC) in Souderton, Pennsylvania. Her students will learn about local industries and job training opportunities, then prepare a skills inventory and assessment profile called "A Plan for My Future."

Karen Holmes, who tutors adult students for the MOC Head Start's Family Literacy Program in Fitchburg, Massachusetts. Her students will learn step-by-step procedures for reading to their children.

Selda Mansour at Eastern Mediterranean University in Famagusta, North Cyprus. Selda's students will use videotape to record short oral presentations and evaluate their speaking skills.

Shirley Novak of Partners in Learning, Inc., Syracuse, New York. Her students will do a hands-on woodworking project.

Georgia Parmer in Canton, New York. Georgia tutors a Korean student for LVA St. Lawrence County. She will help her student to write a history of her experiences and produce them in book format.

Dianne E. Scott of the Nashville, Tennessee Adult Education program. Her project, "Cooking up Cultures," will enable the students to tell about cultural activities that relate to special foods from their country.

Jane Brody of the Sterling Municipal Library in Baytown, Texas was awarded a renewal of her grant from last year. (You can read about her project on page 8 of this issue.)

Applications for next year's grants are available upon request from *Hands-on English*. ➔

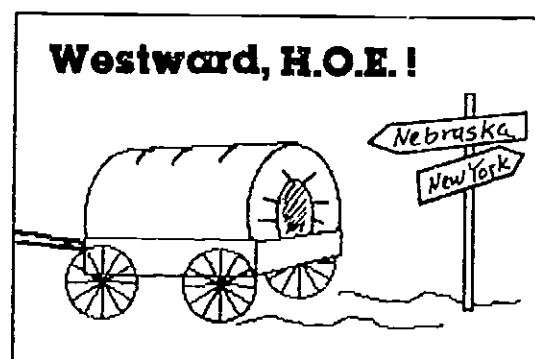

We've moved. . .see page 4 for details!

Hands-on English

Volume III, Number 2
July/August 1993

Hands-on English ISSN 1056-2680, is published six times a year: Jan., Feb., March/April, May/June, July/Aug., Sept./Oct., Nov./Dec. by Hands-on English, P.O. Box 256, Crete, NE 68333, USA

Copyright © 1993 Hands-on English

Subscription rates: \$16 for regular subscribers, \$10 (discounted rate) for volunteers or teacher's aides, \$22 (multi-user rate) for libraries or institutions. Single copies are \$4 each. **Postage & handling:** Canada and Mexico add \$4; outside N. America add \$10.

Permission to photocopy: This periodical is copyrighted. However, we invite teachers and tutors who have a paid subscription (or whose institution has a paid subscription) to make as many copies as they need for their own classroom use. Please don't make copies for colleagues! We survive on the subscriptions of our readers.

Editor: Anna Silliman
M.A. Teachers College, Columbia Univ.
Consulting Editor: Karen Campbell

Address correspondence to the editor:
Hands-on English
P.O. Box 256
Crete, NE 68333 USA
Phone/fax: (402) 826-5426.
(This is our new location as of 7/93)

Subscribe today!

Send this form with your check or money order (U.S. funds only) to the above address.

Please send me a subscription to *Hands-on English* for one year (6 issues). I enclose:

- \$16 for a regular subscription
- \$10 discounted rate for a volunteer or aide
- \$22 multi-user rate for a library/institution
- postage/handling: Canada/Mexico add \$4.
- Countries outside N. America add \$10.

Name: _____

Address: _____

Institution: _____

Position: _____

III-2

Multi-level word matching: Occupations

This game and the puzzles (pp. 6 & 7) contributed by Mary-Jane Lucas. Thanks to Kevin Lucas for the pictures.

Word matching is played like *Concentration*—players put the cards face down in rows, then take turns trying to find two matching cards. This is a low-key, quiet activity that is a very good way to reinforce vocabulary.

Pre-literate students: Make two sets of the picture cards for each group of students playing. Make sure students know the vocabulary before beginning to play. To make a match, the students have to *say* the name of the occupation correctly.







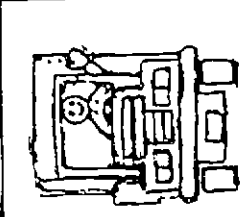
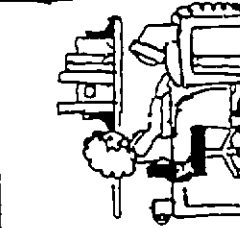
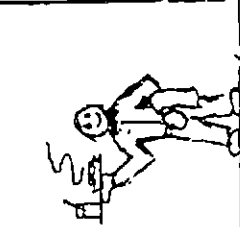
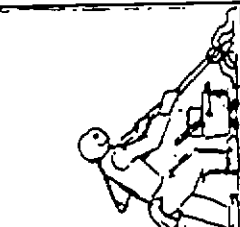

Beginning students: Make a set of the picture cards and a set of the word cards for each group of students playing. The students have to match the word to the picture.

Intermediate/Advanced students: First, discuss the reasons for alternate terms for some common job names. These are **a)** dignity for the worker, i.e. 'maintenance worker' as opposed to 'janitor', **b)** gender equity, i.e. a woman police officer, and **c)** accuracy, i.e. an oral surgeon does different work than a dentist.

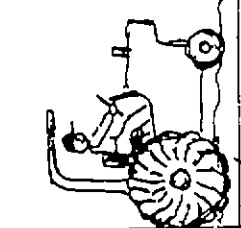
Next show the list of these alternate terms (scramble them first) on the board or overhead and ask students to match them to the more common job titles.

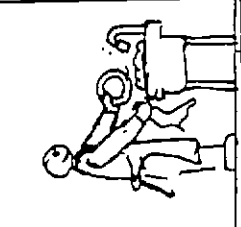
To play the card game, make a set of the common terms and a set of the alternate terms for each group of students playing. To make a match, the students have to pair the common name with the alternate one. ←

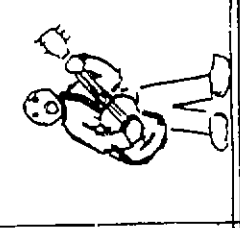
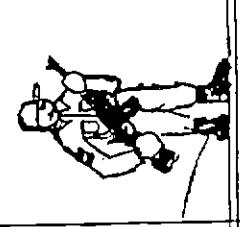
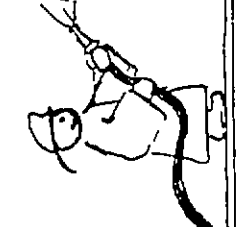
truck driver	transport operator
secretary	office assistant
waiter	food service worker
janitor	custodian/maintenance worker
plumber	sanitation engineer
farmer	agricultural businessman
pilot	aviator/flight engineer
dishwasher	kitchen staff
carpenter	builder
musician	entertainer/composer
soldier	military personnel
fireman	firefighter
artist	graphic designer
nurse	hospital staff
seamstress	dressmaker/garmentworker
waitress	food service worker
policeman	law enforcement officer
mechanic	auto repair technician
dentist	oral surgeon
doctor	physician

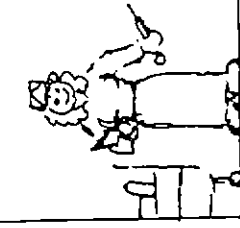
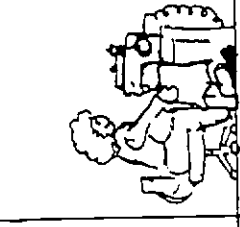
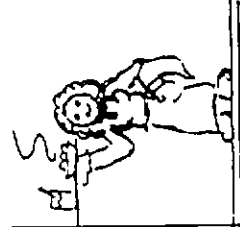
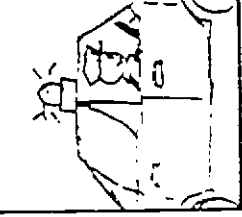
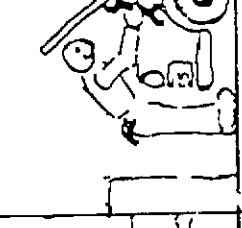
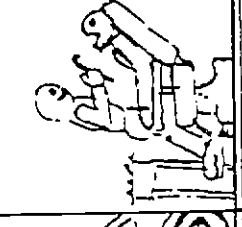
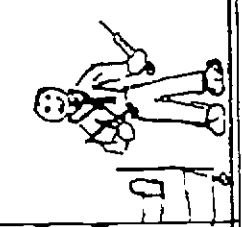
				truckdriver	secretary	waiter	janitor
				plumber	farmer	pilot	dishwasher
				carpenter	musician	soldier	fireman
				artist	nurse	seamstress	waitress
				police man	mechanic	dentist	doctor

Editorial: Moving blues

Hands-on English relocated to Crete, Nebraska this summer—a small community outside the capital city of Lincoln. Our office (in the home of the editor) overlooks a small lake with a flock of Canada geese. In Crete, our new post office, library, bank, phone company and a Chinese restaurant are all within just one block of each other. Ah, the good life.

Crete has a population of about 5,000 and has several industries that employ immigrants. It also has Doane College, a small school with an ESL institute of good reputation. There is a refugee resettlement program in Lincoln, about 15 miles away, and several institutions that offer ESL there, so we won't lack for colleagues.

Move? No sweat.

We ESL people like to think of ourselves as a worldly bunch—trotting around the globe, teaching here and there, hob-nobbing with other cultures. 'Adaptable' is our middle name, right? That's why we have been so surprised to find out how disorienting a move can be.

Stranger in a familiar land

Anybody who has moved a household recently can tell you how trying the experience is—even just within the U.S. For a few weeks, you feel lost without your belongings (*I don't know where I packed the answering machine!*), you have a massive number of reorganizing tasks (*How do I register my car here?*), and certain things are done differently than where you came from (*That's not how we do it in New York!*).

Not only that, but you don't know people yet, so who do you ask about the numerous small things you need to know (*Which is the best grocery store? Which channel is PBS??*) Lots of small problems that don't seem too important individually are unsettling as a whole.

Differences in climate (*Are monsoons normal in Nebraska?*), difference in environment (*What is that yipping noise at night? Should I worry?*), and different modes of behavior (*Did I say something insulting without meaning to?*) all add up to strangeness for the time being. And this is within the same culture, in the same language!

We are humbled to think of the readjustment our ESL students are making. Once again we are reminded of the tremendous personal

stamina, flexibility and humor that many of our students exhibit during a change that is drastically bigger than ours has been!

Let us share this thought: If it takes this editor six months to adjust to Nebraska (which it might), for heaven's sake our students should give themselves *at least* two years (maybe more) to feel comfortable in a new country!

We should have patience with their nervousness, fears, distractions and moods. They are, after all, going through a change greater than any we will probably ever have to make. And, we should admire their courage.

Our new hotline

To make sure we stay in touch with you, we have acquired an 800 number. We hope you'll call us if you have questions, comments, ideas, suggestions or just things you'd like to tell us about.

Call 1-800-ESL-HAND (That's 1-800-375-4263.)

Lost letters?

Relocating yourself and your household may be bad enough, but relocating a business is no picnic either! *Hands-on English* had a few days of panic when the post office in Syracuse, New York forwarded all our business mail to Crete, North Dakota by mistake. Our worst nightmare come true!

If you've recently written to us and haven't received a response, don't hesitate to call us, or write us again at our new address. ↵

Save this card!

New address. 7/93

Hands-on English

Hands-on English
P.O. Box 256
Crete, NE 68333

Phone/fax: (402) 826-5426
Toll free call-in: 1-800-ESL-HAND

Immigrants
applications due
4/30.

Editor:
Anna Silliman

Limerick Latino

by
Sal Parlato, Jr.

Juan had hoped that the fair *señorita*
(who certainly wasn't a shrew)
would—eye-to-eye—verify
his feelings and salute him with *tu*.

His wishes (but inwardly pleaded)
—*¡que lástima!*—all went unheeded.
In fact his tact back-fired instead,
as she reacted with tired "*usted*."

Defeated, our Spanish roméo
retreated without an *olé*. So—
he came to the United States where
he hoped that more favorable fates there
y a linguistic that's *muy* equalistic
would serve him anew, *con* dual-purpose YOU.

Entonces, as love's luck would have it,
that idiom's second-person habit
bobbed up like a cork in foreign New York
in the form of a born-here American.
For, whom should he meet,
(and feel good off his feet)
but Evita, a sweet Puerto Rican!

Evita soon ended his anguish
of *vida* spent lonely and single,
for—*¡Díós* be praised!—
they *ambos* were raised
to be supple in *mas* than one language.
Now as a result, *hay* cause to exult:
this couple was non-monolingual! ➡

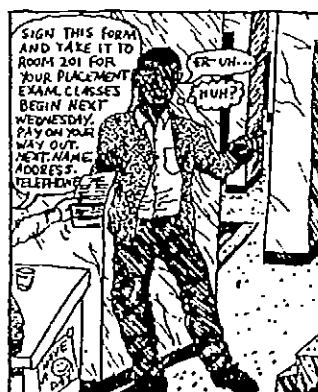
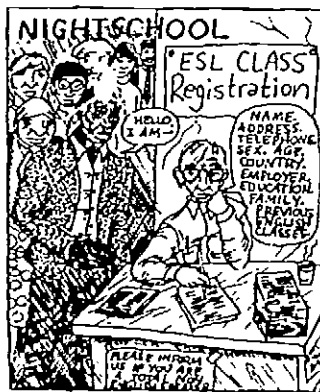

by M. Capurso

TEST COPY AVAILABLE

167 5

Hands-on English, Vol. III, No. 2

Occupations

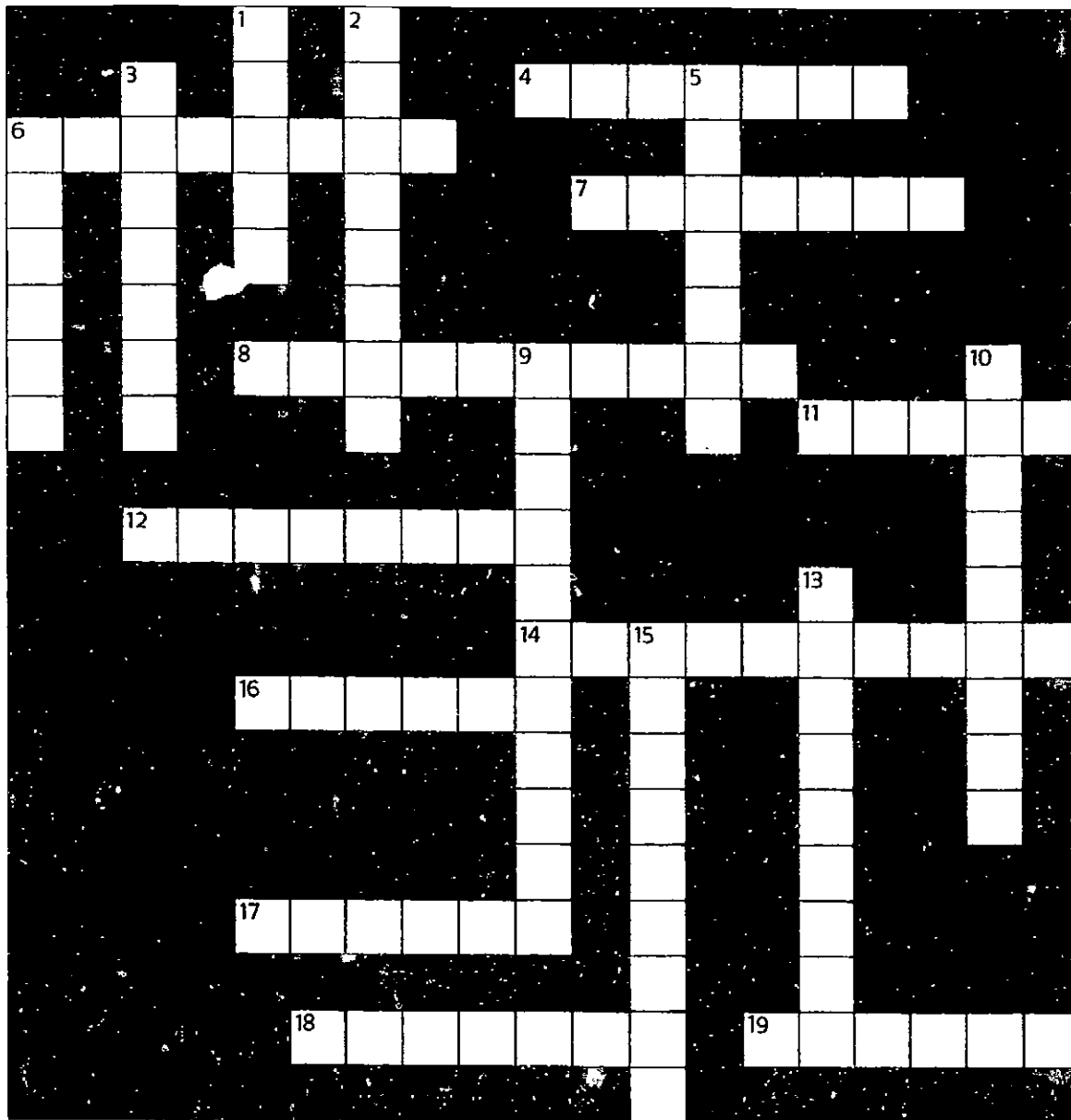

Across clues

4. A person who is in the military.
6. A woman who works in a restaurant.
7. A person who cleans the building.
8. A person who sews clothes.
11. A person who flies an airplane.
12. A person who fixes cars.
14. A person who washes dishes.
16. A person who cures sick people.
17. A person who grows food.
18. A person who fixes toilets and sinks.
19. A person who makes something beautiful.

Down clues

1. A person who works in a hospital.
2. A person who plays music.
3. A person who puts out fires.
5. A person who takes care of your teeth.
6. A man who works in a restaurant.
9. A person who drives a truck.
10. A person who catches criminals.
13. A person who builds houses.
15. A person who works in an office.

Occupations

N S H M M Z P O K G I L M W W M S T Q O N
F I R E M A N T G F R Q X W T X C P Q R T
A R M C Q K F S M D C H S K T Q P T A F D
K V L H F J F C A Q K Y F U E I L Z Q C Z
M S P A R T I S T U S V R S L I U M R I U
E C I N M A S E A M S T R E S S M W C Y M
R X D I S H W A S H E R C H V K B V V P W
K Z E C U K Y B S X B U A R H W E I P I X
Q L N U R S E T O S E C R E T A R Y P Q R
B H T L S L P I L O T K F O L I C E M A N
F A I B C C W B D I D D E X L T X B U B E
Z M S T G J A N I T O R N Y O R V R S I P
P G T U S Y I G E F C I T Z D E D S I F J
K Q Q F T O T W R H T V E P I S H N C U U
J A L Y L U E P P N O E R Q E S T H I V S
D D I H T Q R A F G R R B Y P V E D A Z F
X U B Y B A T O G H P T L A J Z T W N H I

Word search

Find these words and circle them:

artist
carpenter
dentist
doctor
dishwasher
farmer
fireman
janitor
mechanic
musician

nurse
pilot
plumber
policeman
seamstress
secretary
soldier
truckdriver
waiter
waitress

★ Minigrants '92 award winner: "Brighter Horizons" Student Incentive Project

by Jane Brody, Literacy Specialist at
Sterling Municipal Library, Baytown, Texas.
This project demonstrates the power of positive
feedback!

Who they are

The students who participated in the *Brighter Horizons* Student Incentive Project all speak Spanish as their first language. All are employed as contract workers at the Exxon Baytown Olefins Plant (B.O.P.) in Baytown, Texas, which is a petrochemical facility. The students work in a variety of occupations at the plant—they are mainly painters, laborers, scaffold builders and custodians. All but one of the 17 current students are male. Some students have been in this program for three years, some for two years.

This program is a workplace literacy project, in which students are taught basic English, speaking, reading and writing skills using familiar materials from their job sites. Students attend one classroom session and one tutorial each week. Of all the skills that students must master, writing is the most difficult for many of them.

The incentives

Our library's regular literacy program publishes student writings quarterly in a booklet called *Brighter Horizons*. In order to encourage our workplace literacy students to submit stories for the publication, we devised an incentive program—for every three stories submitted to *Brighter Horizons*, the students earn a free adult book.

Students turn their stories in to the instructor who is responsible for logging all entries. Each time a student reaches the goal of three stories, he or she is invited to select a free book. Then, the student is given a round of applause by the class. Recently, the first students from each class who achieved this goal were formally recognized at a tutor/student meeting.

A total of 34 books were purchased with this grant. The students can choose from a variety of pleasure reading texts at different levels. The most popular selections so far have been biographies and adventure stories.

Results

The results of this incentive project have been prodigious, and the *Brighter Horizons* publication now includes many of the workplace literacy students' stories. Students have indicated that their writing has affected their other expressive skills. One man noted recently, "I think this writing helps me to speak better English." Another student, who had to learn how to hold a pencil when he first entered the program, has already completed two stories.

The incentive program offers a small reward for students who take time to write outside of the regular sessions. This has resulted in some students sharing painful experiences. For example, one student wrote a poignant essay about what it was like to be left-handed when he was a child.

Students bring copies of *Brighter Horizons* to class now and discuss the stories. Their pride of accomplishment is very evident. ☛

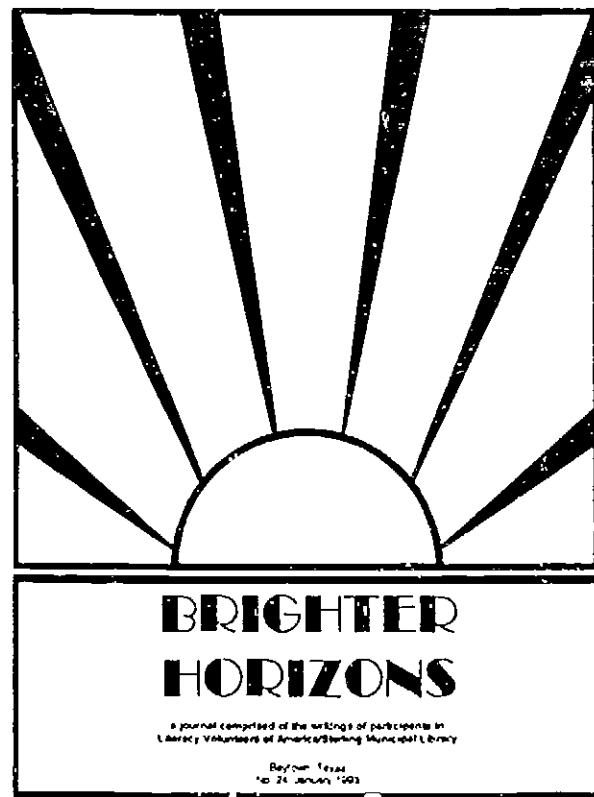

Hints & tips:

Applying for a grant

Applying for a grant may seem pretty scary if you haven't tried it before. To help you get started, we thought you'd like to see what our Minigrants form looks like, and read a sample proposal. See? It's not so bad.

Tip: The most important part of any grant proposal is your description of the students' needs, and how your project will address those needs. If this part is well thought out and convincing, you have a good proposal. ➔

Page 2 of 2

Title of Project: Folk Tale Exchange

- Brief summary of project. Students will read and discuss some of our traditional folktales and look at children's books illustrating them. Then they will retell a folktale from their native country.
- What is the educational objective for this activity? To become familiar with some of the stories common to our culture, to practice listening & speaking skills to gain confidence in presenting to class, to learn about other cultures.
- Describe the activity the student(s) will do: We will read at least 2 folktales (ie Little Red Riding Hood) and discuss the lessons they contain. We will compare versions of these tales in various children's books. The students will then each select a tale from their own culture & retell it first in a small group, then to the class. Students will write a tape record or write their tales.
- How much time will the student(s) spend on this activity? 3 or 4 sessions
Proposed completion date Oct 30
Proposed starting date Oct 1
- Describe the needs addressed by your project, and any benefits you anticipate to the student(s). The students need presentation experience and this is a non-threatening way to start. They will benefit from the self-respect associated with sharing something from their own culture. Their taped or written stories may also benefit their children and other students.
- What problems do you anticipate? Students may be surprised at first to be studying 'children's' stories.
- Budget. Give your best present estimate of the costs necessary for your project (The applicant is not required to adhere to this budget—it is for evaluation of the project)

12 copies, paperback folktales book	- \$50
12 blank cassette tapes	@ \$31
art supplies (as needed)	@ \$1
	Budget <u>u</u>

Matching monies (if any) \$ _____
Source (if applicable) _____

Here's an example of how our committee scores a proposal:

Reviewer feedback sheet
for Hands-on English Minigrants, 1993

Name of Applicant: _____
Title of Proposal: Justin Exempt Folk Tale Exchange

- Does the project address the needs of the student(s)?
Excellent Yes good Good Fair Poor
- To what degree will this proposal directly benefit the applicant's student(s)?
Excellent Yes good Good Fair Poor
- Is the proposal practical in nature? (i.e. directly involving students in an instructional activity?)
Excellent Yes good Good Fair Poor
- Is the planned activity clearly described?
Excellent Yes good Good Fair Poor
- Is there a clear, well defined educational objective?
Excellent Yes good Good Fair Poor
- Is the proposed activity innovative or show creative use of materials?
Excellent Yes good Good Fair Poor
- How do you perceive the financial need of the applicant's program?
Excellent Yes good Good Fair Poor
- Is there matching money?
Excellent Yes good Good Fair Poor
- Might other teachers/tutors be interested in hearing about this project for its results?
Excellent Yes good Good Fair Poor
- Other comments (if any):
A nice activity - sounds like fun.

How will instructor help SS to prep presentation

Answer key

Here are the solutions to the puzzles found on pages 6 and 7 of this issue:

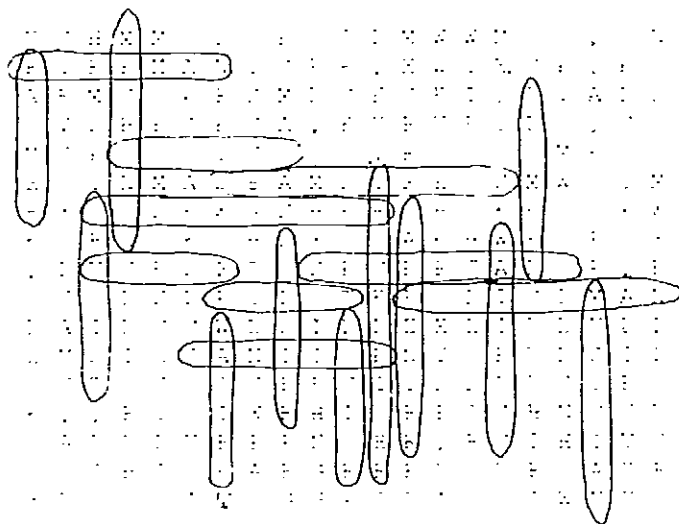
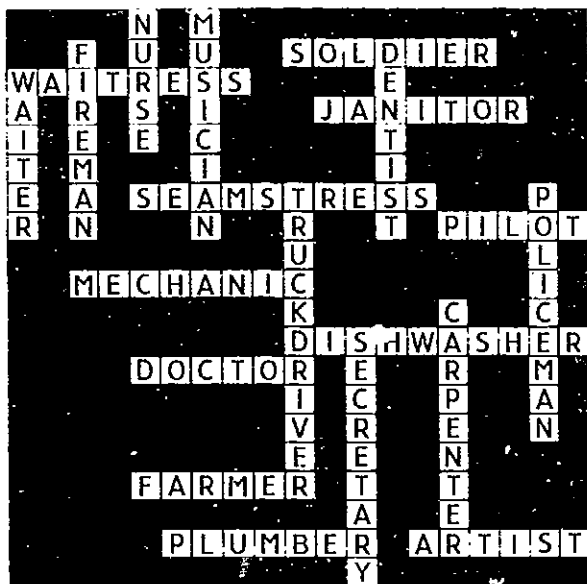

Classified ads

Your ad goes here

Our "classified" section gives you a chance to network with people and find out about products & services of interest to you.

Classifieds can include notices about schools, courses offered, publications, new products, and special offers or requests from our readers.

To place a classified ad, send your notice of 30 words or less with US \$10 (or if you are a subscriber, take a DISCOUNT of 50%) to:

Hands-on English
P.O. Box 256
Crete, NE 68333 USA

Our phone/fax number is (402) 826-5426.
Toll free call-in: 1-800-ESL-HAND.

Publications:

Index Card Games for ESL. 6 game techniques, 70 sample games using 3x5 cards. For any age/proficiency level. Easy and fun to play. \$9.50. *Pro Lingua Associates. (800) 366-4775.*

Now available—THE ESL LOCATOR: Sal Parlato's updated guide to 1,200 national ESL organizations. Prepaid \$11.50 (includes S&H) from TESOL, Booklink, or from: Dolores Parlato, 248 Seville Drive, Rochester NY 14617.

Back issues of *Hands-on English* are now available at US \$4 per copy (this includes shipping costs). Let us know which issues you're missing! See our address above.

Advertising

Let them know you saw it in *Hands-on English!* Thanks--the editor.



Creative activities for the language classroom
Book 1

NEW!

includes

Teacher's Guide to
A picture is worth... 1000 words...

by
Anthony Mollica
Julie Ashcroft
Anne-Marie Finger

\$24⁹⁵ each

Add \$4.00
for Shipping



Creative activities for the language classroom
Book 2

- ✓ 60 Photographs by North American photographers
- ✓ Each photograph may be photocopied for classroom use

Detachable Line-Masters for reproduction

- ✓ Excellent visual stimuli for comprehension and discussion
- ✓ Suitable for different grade level and multi-level classes

The Guide provides a series of questions to stimulate the students'
✓ visual comprehension ✓ personal interpretation ✓ creativity
at three linguistic levels

- ✓ beginning ✓ intermediate ✓ advanced

A Teacher's Guide is available in

- English French German Italian Spanish
- (Please specify language.)

éditions SOLEIL publishing inc.

P.O. Box 890 • Lewiston, New York 14092-0890 • Tel./Fax (416) 788-2674



Intercultural
PRESS

Your direct source for books, videotapes, and training materials on intercultural relations, cross-cultural adaptation, diversity and multicultural education.

Call or write to receive a free copy of our latest catalog.

P.O. Box 700 • Yarmouth, ME 04096
(207) 846-5168 • Fax (207) 846-5181
1-800-370-BOOK (in the U.S.)

EDUCATIONAL SHOWCASE

Your ESL Connection

Providing ESL/EFL Programs for All Ages

The Largest Collection of ESL Materials
on Display in the Midwest

- * Place orders by mail or fax: (313) 680-1052
- * UPS delivery in 5 to 10 days of in-stock items
- * We meet publisher's prices AND beat the service
- * To order or to receive our comprehensive ESL catalog write to:



EDUCATIONAL
SHOWCASE
1334 Wheaton Street
Troy, MI 48083
(313) 680-0860

Letters



and calls

Timing problems

"We really enjoy your magazine and find many of your suggestions of practical use. However, date-specific items, e.g. holiday activities have to be filed away for next year because our copy doesn't arrive until the very end of the magazine's two-month period. If possible, could you get it to us in a more timely fashion?
Thanks,

-B.F., Salt Lake City, Utah

Starting with our next issue, we are changing our publication schedule to help solve this problem. We hope to get you your issues by the middle of the period (ie., the end of September). In the meantime, thanks for your patience!

Prejudice a concern

Ⓒ Ryan Simmons of FIRN in Columbia, Maryland called our office recently. FIRN, or the "Foreign-born Information and Referral Network" is a volunteer agency which has many tutors working with ESL students. Ryan reports that in the county in which they are located, 20% of the population has a first language other than English! Wow!

We agreed that the prejudice against foreigners that is sometimes evident in many parts of the country is quite frightening, and that teaching & tutoring ESL can be a lonely, although rewarding experience. ↵

Hands-on English welcomes your letters, cards and calls--let us hear from you!



A periodical for teachers and tutors of adult ESL
P.O. Box 256
Crete, NE 68333
USA

ADDRESS CORRECTION REQUESTED

July/August issue

(Publication delayed until September)

174



Hands-on English

A periodical for teachers and tutors of adult English as a second language

Grammar grab-bag:

Student interviews

“because”
“in order to”
“so that”

Having your students interview each other is a great way to get some language flowing, which you can then use for a grammar lesson. In this example, students will be asked several “why?” questions (For example: *Why did you come to this country?*) which will hopefully lead to some interesting conversation.

Later, they will write something about the student they interviewed, using some special structures to show reason and purpose.

How to do it

Make copies of the interview sheet on page 9 of this issue. You’ll need one for each student, but make some extras in case anyone finishes early and wants to conduct a second interview.

Pair up the students for the interview—it might be most interesting for them to interview someone they don’t know very well. Ask the students to take some notes on what their partner says. Give them as much time to talk as they would like.

Writing

When the interviews are finished, have the students write a paragraph about the person they interviewed. You can demonstrate this first on the board. Give them 15 or 20 minutes to do this.

If the students have already learned how to use “because,” “in order to” and “so that,” remind them of these structures by writing them on board and suggesting they try to use these in their paragraphs. If the students haven’t learned these structures yet, wait until

after they have finished writing to introduce the grammar.

Sentence combining

You can show the class how to use these structures by combining sentences, such as: “He came to this city. He wanted to live with his uncle.” Rewritten, the sentence is: “He came to this city *because* he wanted to live with his uncle.” Or, “...*in order to* live with his uncle.” Or, “...*so that* he could live with his uncle.”

Do lots of examples of this, until the students are comfortable with it. (Many grammar books have exercises like this if you need some more examples.) Then, have them look at the paragraph they wrote to see if they can use these structures in their own writing.

When the paragraphs are done, they will make interesting reading for the whole class, so try passing them around or posting them. ➔

Contents

Puzzle:	
– Dictionary Puzzle 2.....	2
Idea file:	
– News photo captions	4
Letters	5
Editorial:	
– Myths about learning English	6
Hints & tips	7
Tools & techniques:	
– Dictionary game	8
On the market:	
– Review of “Look Who’s Talking!”	13
News & notes	13

Hands-on English

Volume III, Number 3
September/October 1993

Hands-on English (ISSN 1056-2680) is published six times a year (Jan./Feb., March/April, May/June, July/Aug., Sept./Oct., Nov./Dec.) by Hands-on English, P.O. Box 256, Crete, NE 68333 USA.

Copyright © 1993 Hands-on English

Subscription rates: \$16 for regular subscribers, \$10 (discounted rate) for volunteers or teacher's aides, \$22 (multi-user rate) for libraries or institutions. Single copies are \$4 each.

Postage & handling: Canada and Mexico add \$4; outside N. America add \$10.

Permission to photocopy: This periodical is copyrighted. However, we invite teachers and tutors who have a paid subscription (or whose institution has a paid subscription) to make as many copies as they need for their own classroom use. (Please don't make copies for colleagues! We survive on the subscriptions of our readers.)

Editor: Anna Silliman

(M.A. Teachers College, Columbia University)

Consulting Editor: Karen Campbell

Address correspondence to the editor:

Hands-on English

P.O. Box 256

Crete, NE 68333 USA

Phone/fax (402) 826-5426.

Toll free call-in: 800-ESL-HAND

Subscribe today!

Send this form with your check or money order (U.S. funds only) to the above address.

Please send me a subscription to *Hands-on English* for one year (6 issues). I enclose:

\$16 for a regular subscription

\$10 discounted rate for a volunteer or aide

\$22 multi-user rate for a library/institution

— postage/handling: Canada/Mexico add \$4.

Countries outside N. America add \$10.

Name: _____

Address: _____

Institution: _____

Position: _____

III-3

Crossword: Another dictionary puzzle

We published a dictionary puzzle about a year ago (see Vol. II, No. 2, July/August 1992) to help students learn to use an English/English dictionary more effectively. Because many readers responded with enthusiasm, we've decided to supply you with another one for additional practice.

Too hard for your students?

We think there is a time and a place for dictionaries in ESL, but frankly, bilingual dictionaries often don't help very much. Students who rely on them seem to get more and more confused about what's going on.

Using an English/English dictionary is lots harder than using a bilingual one, especially for students whose English is not very advanced. However, the more familiar students get with this tool, the more they will start thinking in English and making new connections with the vocabulary they know.

If students will stretch themselves and learn to use an English/English dictionary, they can become more powerful and independent as learners!

How to do it

Make sure each student has a dictionary, even if they are working in groups. Unless your students are quite advanced, they should be using a dictionary written specifically for ESL students. We like *The Longman Dictionary of American English* because it is very clearly written and not too expensive. (ISBN 0-582-79797-7, about \$14.)

The students might enjoy working on this puzzle in small groups or teams. Or, they can do it independently as a homework assignment.

Follow up

To expand on the students' dictionary skills, have them prepare some questions similar to those in the puzzle, for other students to answer. For example, "The word 'student' is on page _____ of the dictionary." They could write about 10 questions each, then exchange papers and try to answer the questions using the dictionary.

Why it works

A dictionary can seem pretty tedious or overwhelming to students, so providing a game with the spirit of a 'treasure hunt' makes it easier for them to dive in and get started. ☛

Dictionary puzzle 2

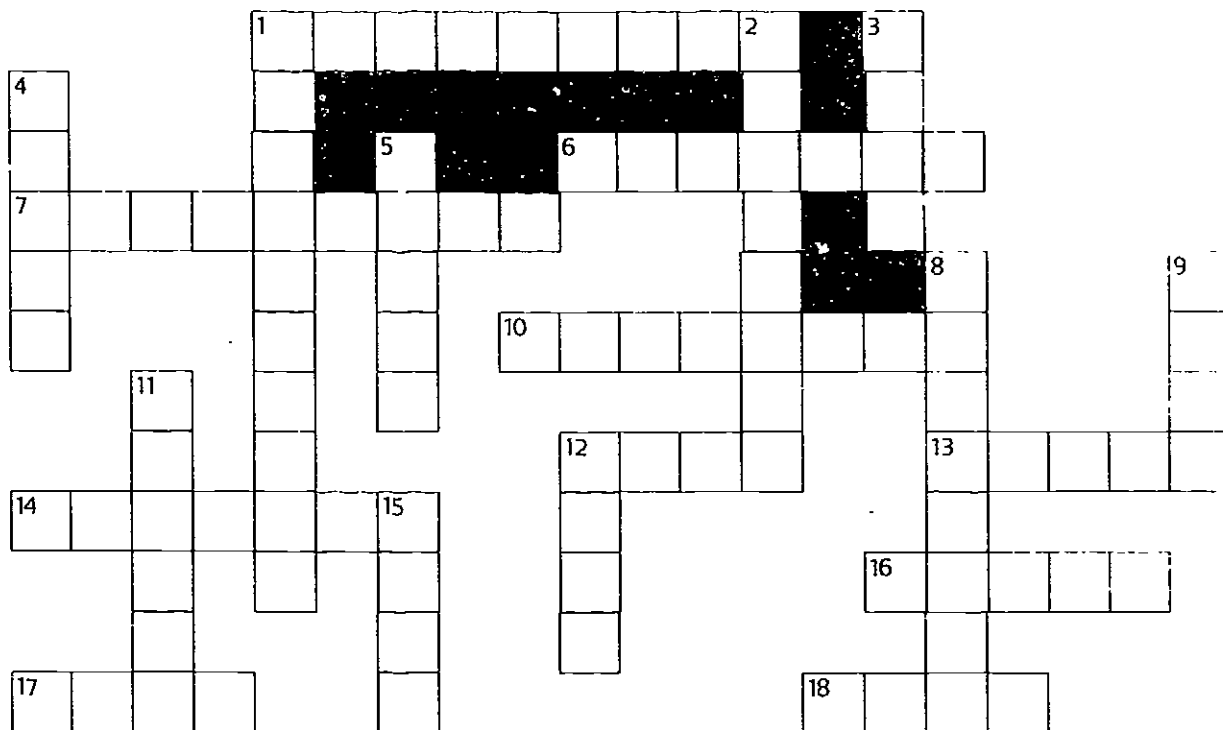

Use an English/English dictionary to find the answers to this puzzle!

Across clues

1. "OPEC" means Organization of _____ Exporting Countries.
6. Which is the correct spelling?
ablety, ability, abiletty
7. "adj." is the short form for _____.
10. "sing." is the short form for _____.
12. A *pentagon* is a shape with _____ sides.
13. What is the past tense form of *shake*?
14. What is the past tense form of *bring*?
16. A synonym for *furious* is _____.
17. A *robin* is a kind of _____.
18. Is the word *achieve* noun, a verb, or both?

Down clues

1. Which is the correct spelling?
psychology, psychology, psycology
2. Which is the correct spelling?
molecule, molacule, molicule
3. Is the word *work* a noun, a verb, or both?
4. A synonym for *depart* is _____.
5. An *octagon* is a shape with _____ sides.
8. "POW" means _____ of War.
9. The symbol \cup has a sound like in:
boat, book, bomb.
11. A *marigold* is a kind of _____.
12. A *quadrilateral* shape has _____ sides.
15. A *beech* is a kind of _____.

Idea file:

News photo captions

Here's a speaking activity submitted by Sally Lockwood, ESL teacher for adults in Coldwater, Michigan. As you will see, this activity is easily adapted to many different kinds of students, at different levels, and even mixed levels!

Preparation

Cut out enough newspaper photos for at least half your class. Separate the captions that go with them, and make some extra copies of these. Now put each photo in an envelope and distribute them to half the students. For the other students, give each one an envelope with 3 or 4 captions in it.

How to do it

Explain that some students have a newspaper photo and some have captions (if they don't know what captions are, show them what you mean by pointing to a newspaper). The students with captions will try to find the right photo, BUT—without seeing the photos! They will have to ask questions until they find out who has the right photo.

You might want to demonstrate the questioning for the students. For example: "I'm looking for a picture of two men shaking hands. One of them is President Clinton. Do you have this picture?"

Give the students time to circulate and ask questions. You can help by making sure nobody peeks, and by providing vocabulary help when needed. The activity is finished when all the students have matched their captions with photos. However, if the the students are enjoying the activity, they could exchange envelopes and do it again.

Adapting to your students

The beauty of this activity is that you can adapt it to fit the interests of your students. Do they enjoy human interest or humorous items? Are they interested in local events? Do they like to discuss issues of national or world importance? Assuming you have a bundle of newspapers to clip from, you can find items to interest just about anybody.

For multi-level groups of students, it makes sense to give the captions to the more advanced students—they have the challenging job of



interpreting the caption, imagining a photo that might accompany this caption, and describing it to someone else

If the original captions that came with the newspaper photo are too difficult for your students to read, just rewrite the captions in simpler language, using a 3x5 card for each one. This increases your preparation time, but makes the activity less frustrating for the students.

Tutors, too

If you're working with just one student you can have a lot of fun with this activity, as well. Cut out four or five newspaper pictures that might be of interest to your student. Choose captions (or write some) that are suitable for his or her reading level. Spread the photos and the captions out on a table and have the student find a caption to match each photo.

Why it works

Because the students are looking for information from each other, the interaction among them is made natural. They have a specific problem to solve, which can only be done by listening to each other and trying to communicate.

Another reason for the success of this activity is the adult content. Our ESL students want to participate in discussing the news just like everybody else, but it is often much too difficult for them to do so. This activity gives them a chance to talk about news items in a limited context.

Follow up

This activity might be one good way to start a discussion on a current events topic. For example, if many of the photos were about health care issues, students might want to discuss health care in this country. ↵

Idea file



Keep this card handy in your 'idea file' in case you need an activity in a hurry!

News photo captions

Purpose: To encourage interaction in speaking; listening comprehension.

Level: Intermediate to advanced

Time: 15 minutes

Materials: Some newspaper photos with captions (separated); envelopes

Preparation:

1. Cut out some news photos with captions; then cut off captions and separate. Make a photocopy of the captions, so you have some extras to distribute.

Activity:

2. For half of the group (more advanced students), give each student an envelope containing 3 or 4 captions.
3. For the other half of the group, give each student an envelope containing a photo.
4. The students with captions must circulate and ask individuals if they have a certain picture (verbally only—no peeking!).
5. The questioners keep asking different students until they find the one who has the matching picture.

Letters



"Class Journal" a success

"I used the 'Class Journal' idea (see Vol. II, No. 5, Jan/Feb 1993) last year. It was terrific. My high school students really got into producing a whole page of text with pictures, fancy lettering, flowery borders, etc. The whole thing was a work of art. It included copied poems, homely wisdom, philosophy, anecdotes. It purely evolved. We drew names at the end of the year to give away the book."

- Carol Small, Saratoga, CA

Unsolicited comment

"You are doing a wonderful job with your publication. Please continue the excellent work."

- Irene Baydarian, Bayville, NY

Thanks for the encouragement! - Editor

Speaking of poetry. . .

One of our readers responded to our poetical renewal notice with some verse of her own:

"In my time I've wasted a dollar or two
But I never mind sending this sixteen to you.
'Cause you don't clutter the pages with theory
Keep sending those *practical* lessons, deary!"

- Juanita Zwaryczuk, Bellport, NY

Homogenous class

Jeri Manning, who will be teaching English in Japan, writes: "I would love to hear from other teachers who are in culturally homogenous classrooms!"

If you have some suggestions for her, send them to *Hands-on English* and we'll pass them along.

Letters, continued on page 16. . .

Hands-on English, Vol. III, No. 3

Editorial:

Myths about learning English

He "just picked it up"

One of the common misconceptions about learning English is that it is easy. Another common idea is that it doesn't require specialized instruction. The general American public seems to believe both of these myths. In newspapers anywhere in this country you can read comments like: "My grandfather didn't have ESL (or bilingual) classes when he came to this country, and he learned English and did just fine."

However, we should ask some questions about the writer's grandfather, such as: How much previous education did he have? (Background knowledge, reading and study skills would make it easier to self-teach.) How many other languages had he already studied? (People who have already learned one foreign language well have an easier time learning another.) What was his occupation, and what kind of English skills did it require? (Some jobs don't require a sophisticated command of the language.)

Also, how difficult was it for him to learn English, and how long did it actually take? (The special sacrifice involved may not have been described to his grandchild.) What special skills and personal aptitudes made it possible for him learn the language? (Some people do have a greater facility with language.) Did the grandfather also feel he was doing 'just fine,' or is that the interpretation of a later generation? (Some immigrants feel a tremendous sense of failure because of their accented or imperfect English.)

Military secrets

A recent example of the simplistic public view of language learning involves General John M. Shalikashvili, or 'Shali,' whom President Clinton has nominated for the position of Chairman of the Joint Chiefs of Staff. In presenting his nominee, Clinton described Shali as someone who immigrated here with his family at age 16, and who "learned English from John Wayne movies so that he could participate fully from the first day of school."

What a great story! Except that there has to be more to it than that. After hearing this comment, we started doing some very careful thinking about General Shali, and have made a

few guesses about his language learning process:

GUESS #1. He comes from what is probably a highly educated, cosmopolitan family (the officer class in Georgia), and his parents and grandparents no doubt all spoke multiple languages. He probably received an excellent education, in part because of his family's aspirations and determination. We'd bet his parents made sure he did his homework.

GUESS #2. He probably learned several other languages before he came to this country. His parents most likely spoke Georgian in the home. In 1921 they fled to Poland, where Shali was born. He lived there the first eight years of his life, so he must have learned to speak Polish. In 1944 his family fled the Soviet army and went to Germany, where Shali must have attended school and of course learned German.

GUESS #3. If he attended German schools for several years, he may have had four to six years of English instruction, an hour a day, six days a week. (He would have also studied German grammar and even Latin.) By the time he left, he would have studied all the English verb forms and read some short stories in English, such as Jack London's *White Fang*.

GUESS #4. Those John Wayne movies were probably very helpful in improving his listening comprehension, polishing up his pronunciation, and teaching him some American slang. But Shali came already prepared with a firm basis in the structure and vocabulary of the English language, and in academic skills for school.

GUESS #5. Even with all this background and preparation, he must have worked very, very hard to achieve the success that he did. We'd guess he got headaches from concentrating so hard at those movies.

Hard work and patience

Sometimes it's not just the public, but also we teachers who forget how much time and how much effort goes into learning a language. It takes *years* of good study, even for those fully prepared to learn. Sharing this concept with our students might help them to feel less frustrated about their progress in English.

By the way, believe it or not, Gen. Shali still speaks with a Georgian accent. It's not easy to learn another language. It's not easy at all. ☞

Hints & tips

Got an idea that works for you? Maybe you'd like to share it with other readers! ESL teachers and tutors are always looking for ideas to try out with their students.

Memory tricks

Do you sometimes have trouble remembering new students' names? Try this visualizing trick: As soon as the students have left at the end of the session, look at each name, then close your eyes and try to *visualize* that student's face. Do this for each of the new students.

Then, a few hours later (perhaps in the evening) do the visualizing exercise again. You'll find this speeds up your learning process.

If this technique doesn't work for you, why not take a Polaroid snapshot of each student as they enroll. You can use these as 'flashcards' to teach yourself the names, then post the photos in the room for the students. They will appreciate the memory aide as well!

More sticky stuff

In a past issue we asked for help in attaching items to concrete block walls. Laura Adams of Antelope Valley College in Lancaster, California, responds with this information:

Almost all stationery stores, drug stores, discount stores (like K-Mart, Wal-Mart, etc.) carry products like **3M Wall Mount Tabs**, which are ideal to hang easel pad sheets, banners, signs, posters and other lightweight objects. They hold securely, yet remove easily without damaging most surfaces. They can even be used on blackboards, glass, and most painted surfaces. 48 tabs in a package sell for approximately \$2.00 to \$2.50.

Blank flashcard sheets

There are about a million different activities for language learning that require writing words or phrases on cards for the students. You can spend a lot of time preparing these, which can be tedious. Later they get lost or thrown away, and you have to prepare them all over again next time.

Here's how to make the process more efficient, and the activities re-usable—prepare a master sheet of blank cards in the size you need, on an 8 1/2 by 11 sheet of paper, like this:

or like this:

Make several copies of the blank flashcard sheet and have them handy. Then, to prepare an exercise, write the vocabulary (or clues, or whatever) in the blank boxes. Photocopy your finished page for as many groups as you need, and distribute to the students (perhaps they can cut them up themselves).

If this is an exercise you might repeat, or use with another class, *don't* hand out your master copy, but save it for your files instead. Next time you won't have to write out all those cards again—just whip out your master and make some more copies. It's easy to make a few changes, too, so you can customize the exercise without too much trouble.

If you're really clever you could set up a blank flashcard page on your computer, then type in new words as needed, and print the page out, ready to photocopy.

Talking about crime

Do any of our readers have suggestions or experience in discussing crime issues with their students? Recent events in the U.S., like the killing of a Japanese student and tourist deaths in Florida have brought this issue to the forefront of attention. We'd be interested to hear your experiences with this. ☞

Here's the solution to the dictionary puzzle on page 3:

	P	E	T	R	O	L	E	U	M	B					
L	S									O	O				
E	Y	E			A	B	I	L	I	T	Y				
A	D	J	E	C	T	I	V	E		E	H				
V	H		G						C		P				
E	O	H	S	I	N	G	U	L	A	R	B				
	F	L	T						L	I	O				
	L	O				F	I	V	E	S	H	O	O	K	
B	R	O	U	G	H	T			O						
	W	Y		R					U		A	N	G	R	Y
	E			E					R						E
B	I	R	D		E						V	F	R	B	

Dictionary game

Word race

We've never been very enthusiastic about contests in the language class. In this activity, however, the competition has some real benefits for your students—it encourages them to skim quickly for specific information, and helps to get them familiar and comfortable with using the dictionary.

How to do it

Divide the class into teams of 3 or 4 students each. Each student should have their own monolingual (English/English) dictionary, preferably one written for ESL students.

Explain to the students that you have a list of some unusual words that they probably don't know. You want them to find out which category each word belongs in, by looking up the words in the dictionary. The team that finishes first (and has the answers correct) wins.

Show the students an example, by first writing the four categories on the board: FISH, BIRD, TREE, FLOWER. Then tell the class one word, such as "phoenix," and have everybody find it in the dictionary. If they agree this is a kind of bird, then write "phoenix" under BIRD.

Now, hand out the contest sheets and let the students begin the game. When one group finishes, check their answers—if there is a mistake, they should continue working on it. (Note that there are two words on the list that don't belong in any category.)

Variations

You may want to make another game with different words, or with different categories. One warning, though—make sure the words on your list are all included in the dictionary your students are using! Otherwise it could prove to be frustrating. Allow yourself plenty of time to prepare a new game.

For advanced students, expand this game into real life by having the students read a newspaper article, using the dictionary. For each word they don't know, have them find a CATEGORY to describe it (not a definition).

Tutors, too

If you are working with just one student, you may want to avoid giving this sheet as homework. If the student takes this list of strange words home, he or she may try to "learn" them all, which is not the point of the exercise! Instead, do the exercise together, and then discuss ways of using the dictionary. ↩

Word list:

Categories:

bass
beagle
cedar
daffodil
dalmation
dandelion
gosling
iris
maple
mussel
perch
pheasant
thrush
willow

	FISH	BIRD	TREE	FLOWER
	1.	1.	1.	1.
	2.	2.	2.	2.
	3.	3.	3.	3.

Student interview

(for instructions, see page 1)

1. Name _____ 2. Country of origin _____

3. Why did you leave your country?

4. Why did you come to this country?

5. Why did you come to this city?

6. What do you hope to do, in the future?

7. Why do you want to do this?



by M. Capurso

Teach Me

by
Sal Parlato, Jr.

Teach me, target of my english,
mutedly class-sequestered here
with globe-gathered kindreds
wrestling, all, with rules and rote
that only academics defend as sense

You, foster son of silence
and Deaf's adopted daughter,
as turnabout-tutor, model for me
by your wisdom, the weakness of words
by your laughter, the limits of logic
by your feelings, the fallacy of fact
by your talent, the treachery of test.

In deciphering me, be master of me.
Become of my tongue a finder of its flaws:
of our common culture, reminder of its laws.

You who to English are new,
let your first-language youth
whether full of words or free
lend me latter-language truth
ultra-linguistically.
Teach me, Learners, do.
Teach your teacher *you*. ↩

A blatant plea for help! (Hint, hint)

If you're a regular subscriber you probably noticed something different about this issue—it's a little longer than usual. *Hands-on English* would love to expand to 16 pages on a regular basis, so we can bring you more good stuff in every issue!

To do this, though, we need to increase our circulation, since most of our operating funds come from subscriptions (and some comes from advertising).

To help us accomplish this goal, would you be willing to help us spread the word about *Hands-on English*? We've printed a flyer here, which you could detach and give to a colleague (or copy and post).

We now have more than a thousand subscribers, all across the U.S. and in Canada (and a few overseas). Let's see...if each subscriber contacted two people...wait—what if each subscriber contacted *ten* people, and they all subscribed...we'd take over the world!

Thank you for your help!

Please send to a friend! 

(Please post or pass along!)

"Hands-on English" is a helping hand for adult ESL!

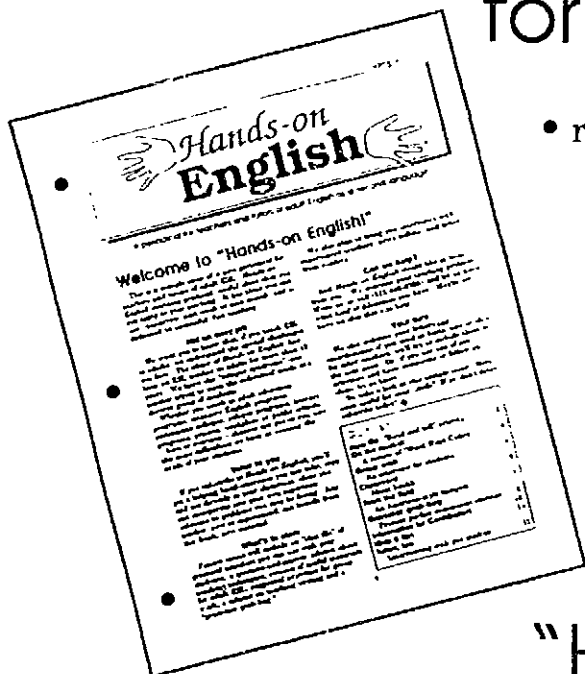

- ready-to use activities
(Puzzles, Grammar 'grab-bag,' Group activities, Conversation starters, Discussion activities and more.)
- ideas, hints and tips
(Cultural activities, Writing projects, Hints from readers, Reviews of useful materials.)
- copyable
(We give you permission to make all the photocopies you need for your classroom use.)

"Hands-on English" . . .

...is published 6 times a year.

...is written by teachers for teachers.

...gives out Minigrants awards every year for classroom projects.

Subscribe today! Send to:

Hands-on English
P.O. Box 256
Crete, NE 68333

For information call: (402) 826-5426
Toll-free number: 800-ESL-HAND

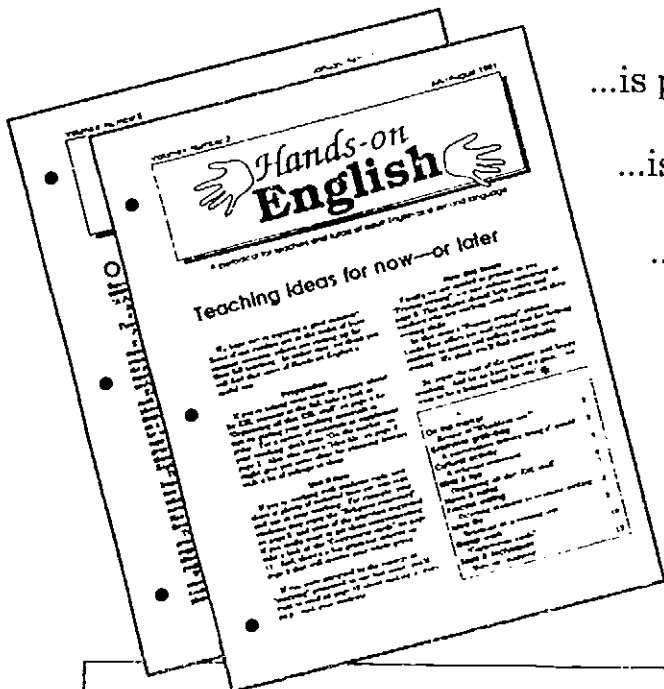

Please send me:

- A subscription for 1 year. \$_____ enclosed.
(\$16 for one teacher, \$10 discounted rate for volunteers/aides, \$22 multi-user/library rate.)
- Minigrants information & application.
- A free sample issue of *Hands-on English*.

Name: _____

Address: _____

Institution: _____

Position: _____

Here's what our readers are saying about "Hands-on English" . . .

"I like the papers that we can copy and hand out to the students, like the exercise on nicknames. All my classes are interested in learning this kind of useful information. Great for multi-level classes. Thank you!"

Paulette Bork
Part-time ESL teacher
Mechanicsburg, Pennsylvania

"I feel inspired when I read it."

Carol Small
High school ESL teacher &
adult ESL tutor
Saratoga, California

"I love Hands-on English! I've used something from every issue! I like the readily usable games and exercises. I find that my learners love the 3-level cross-word puzzles. I've recommended your publication to several friends."

Dorothy A. Holmes
Teacher, adult ESL
Rochester, New York

"I'm grateful to have such a great resource in Hands-on English!"

Kathy Hull
Lead teacher, adult ESL
BOCES So. Westchester
Valhalla, New York

"I am able to pass many of your ideas on to our volunteer tutors. Keep up the good work!"

Reveriy Fitzgibbons
Coordinator for ESL tutors
Catholic Social Agency
Allentown, Pennsylvania

"The item about the politicians and election for president was very good. Current affairs are helpful. This month's ESL Yearbook Project is very good—I will use this even with just one student."

Edith Hanle
Literacy Volunteer tutor
Bayville, New Jersey

"The publication is great! One of the most continually useful resources I have. I really like the activities that are multi-level."

Paula D. Cosko
Classroom aide, adult ESL
Seattle, Washington

"I teach a multi-level adult ESL class...so I'm always looking for lots of new ideas. Keep up the good work! I always look forward to receiving your periodical."

Susan M. Dobie
N. Island College, B.C., Canada

"I like the format a great deal! Hands-on English is easy and fast to read. It gives me a good feeling of down-to-earth support."

Marcia Hannett
Teacher, Refugee Program
Syracuse, New York

On the market

Reviews of useful ESL materials

"Look Who's Talking! Activities for Group Interaction, 2nd edition" by Mary Ann Christison and Sharon Bassano (Alemany Press/Regents-Prentice Hall) 120 pp. \$21.55. ISBN 0-13-539206-3.

Ideas for conversation

We ESL teachers can never get enough language activities—we're always looking for things to use as warm-ups, to fill extra time, to get our students speaking and interacting, and to add spark our lessons. This book certainly belongs in your library of ideas to draw on.

The 78 activities for conversation presented in the book are quite varied. They range from silly and fun activities to more thought-provoking ones. The content ranges from the non-personal (low risk) to the very personal (high risk). Most of the activities can be used with multi-level groups, or adapted for various levels.

Groups, large and small

Some of the activities are teacher-centered, some are for pair work, some for small groups and some are for a large group. The best configuration (labeled 'strategy' in the book) is indicated for each activity, making it easy for you to browse through and choose something appropriate for your students.

Not all of these activities are new—some of them are actually tried and true language teaching exercises—but all are well thought out and carefully presented. Best of all, the authors provide plenty of references to other resources, so if you like one activity you may be able to find more like it elsewhere.

Mix it up!

New teachers will certainly like this book and experienced teachers will also find it useful. The book presents a lot of possibilities for your teaching, and will give you some ideas about how to change the dynamics of your classroom and make things more interesting, no matter what your level of expertise.

Finally, everybody will like the pages made for copying. This is a nice feature that is especially valuable to busy teachers. If you need to adapt an activity, though, some of the variations suggested will be helpful. ➤

--Karen Campbell and Anna Silliman

News & notes

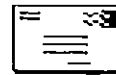

Upcoming conferences

- ♦ October 28-30, 1993—**TRI-TESOL IV** (Washington, British Columbia and Oregon) at the Sheraton Landmark Hotel, Vancouver, BC, Canada. Contact: John Avey, Fax number 206-931-3978.
- ♦ October 28-30, 1993—**Rocky Mountain Regional TESOL** at the Hilton Hotel, Salt Lake City, Utah. Contact: Monica Hilding, 801-364-2824.
- ♦ October 29-30, 1993—**Mid-America TESOL** at the U. of Nebraska, Lincoln, Nebraska. Contact: Sheila Phillips, 314-947-8202.
- ♦ November 5-6, 1993—**Texas TESOL V**, at the Park Central Sheraton Hotel in Dallas, Texas. Contact: Dianne Elkins, 214-578-0779.
- ♦ November 5-7, 1993—**New York State TESOL**, annual conference in Syracuse, New York. Contact: Sharon Heberlig, 315-445-8340.
- ♦ November 6—**Three Rivers TESOL**, annual conference in Pittsburgh, Pennsylvania. Contact: Jerry Gebhard, 412-463-1969.
- ♦ November 11-13, 1993—**Colorado TESOL**, at the Holiday Inn Denver Southeast, Denver, Colorado. Contact: Barbara Sihombing, 303-492-3012.
- ♦ November 11-13, 1993—**International Reading Association (IRA)** Southwest regional conference, Tulsa, Oklahoma. Contact: Gwen Humphrey, 918-747-4119.
- ♦ November 13, 1993—**Northern New England TESOL**, at New Hampshire College in Manchester, New Hampshire. Contact: Lucie Germer, 603-876-4154.
- ♦ November 17-20, 1993—**American Association for Adult and Continuing Education (AAACE)** in Dallas, Texas. Contact: Drew Allbritten 703-522-2234.

more News & Notes... see next page



...continued from page 13.

TV news for students

CNN has an educational program that might be of great value for ESL. The program is called "CNN Newsroom," a 15-minute close-captioned (ie., with subtitles) news program without commercials. It runs 5 mornings a week from 3:45 to 4 a.m. (Eastern Time), so you or your school could tape the program to show your class later.

If you are hooked up to a computer network, you can also download and print out their handouts with exercises based on that day's news. The classroom guide is also available by fax.

For information about how to enroll your school in this educational program, contact: Lucy Levy, Turner Educational Services, One CNN Center, P.O. Box 105366, Atlanta, Georgia 30348. Telephone: 1-800-344-6219.

Immigrants vie for ESL spaces

A recent New York Times article (August 29) showed a picture of 500 immigrants waiting to learn if they were winners in a lottery for only 50 spaces in an ESL program. The free intensive English classes are held at Riverside Church in Manhattan. Many of those waiting described feeling desperate to get in to the program.

The report points out that the demand for English lessons—not just in New York, but wherever there are immigrants—far outpaces the supply. So much for those who think immigrants don't want to learn English!

Multilingual society

A Census Bureau report this spring showed that one in seven U.S. residents (that's 14 percent, or 31.8 million people) speak a language other than English at home. ↵

LifePrints

ESL FOR ADULTS



From New Readers Press

*If you need learner-centered core materials that focus on accomplishing life skills
...and you want lesson planning made simpler and more efficient, then LifePrints is for you!*

This exciting set of core instructional materials for adults and young adults

- powerfully combines learning to communicate in English with learning the ways and customs of North American culture
- opens the way to the English language using activities that present authentic, natural English
- provides opportunities for learners to practice language in situations typical of their everyday lives.

COMPONENTS: Student Book, Audiotape, Teacher's Edition, Teacher's Resource File
Available in 3 levels: low-beginning, high-beginning, and low-intermediate

Developed By Robert Venturi Associates with consulting editors
Allene G. Grognet of the Center for Applied Linguistic and
JoAnn (Jodi) Crandall of the University of Maryland, Baltimore

To receive your FREE *LifePrints* Sampler
Call 800-448-8878 (Dept. 108) TODAY!

Or write to New Readers Press, Box 131, Dept. 108
Syracuse, New York 13210-0131 • 315-422-9121



by
*Anthony
Mollica*

Illustrations:
Nancy Elkin

10 familiar themes
80 line-master puzzles for reproduction
200 high frequency words

Line Masters for Reproduction*

- ✓ for fun and relaxation
- ✓ an alternative to translation, definition or description
- ✓ are excellent for the early stages of language learning
- ✓ for reviewing high-frequency vocabulary
- ✓ direct association between language and image
- ✓ are great for the visual learner

Themes

1. At School
2. Sports
3. Activities
4. Articles of Clothing
5. Means of Transportation
6. At the Farm
7. At the zoo
8. In the Kitchen
9. Fruit
10. Vegetables

* Reproduction rights are granted only for the classes of an individual teacher purchasing these materials. Any further reproduction or different use without the written permission of the publisher is an infringement to the copyright law.

editions **SOLEIL** publishing inc.

P.O. Box 890, Lewiston, NY 14092-0890
Tel. / Fax: (905) 788-2674

EDUCATIONAL SHOWCASE

Your ESL Connection

Providing ESL/EFL Programs for All Ages

The Largest Collection of ESL Materials
on Display in the Midwest

- * Place orders by mail or fax: (313) 680-1052
- * UPS delivery in 5 to 10 days of in-stock items
- * We meet publisher's prices AND beat the service
- * To order or to receive our comprehensive ESL catalog write to:



EDUCATIONAL
SHOWCASE
1334 Wheaton Street
Troy, MI 48083
(313) 680-0860

Classified ads

To place a classified ad, send your notice of 30 words or less with US \$10 (subscriber's get a discount of 50%) to: Hands-on English, P.O. Box 256, Crete, NE 68333 USA. Phone/fax: (402) 826-5426. Toll free call-in: 1-800-ESL-HAND.

Publications:

Now available—THE ESL LOCATOR:
Sal Parlato's updated guide to 1,200 national ESL organizations. Prepaid \$11.50 (includes S&H) from TESOL, Booklink, or from: Dolores Parlato, 248 Seville Dr., Rochester, NY 14617.

Back issues of *Hands-on English* are now available at US \$4 per copy (this includes shipping costs). Let us know which issues you're missing! See our address above. ✎

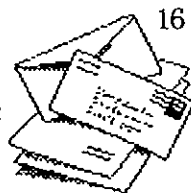

...continued from page 5

Goodbye, and...

Marcia Hannett, who teaches beginning level ESL at the Refugee Program in Syracuse, New York, related to us a touching moment on the last day of class before the summer break. Her students proudly presented her with a beautiful card which they had purchased, and which each student had carefully signed. Imagine her surprise when she opened the card and read the printed message: "Get well soon."

Listening materials?

Ⓢ Mauritzia Liriano in New York is looking for some good listening materials for her intermediate level students. She would like them to hear another voice besides her own! However, many of the materials on the market seem too difficult for them.

Mary Jane Lucas suggested making your own listening tapes by having friends and neighbors record short passages on tape for you. She has done this for her refugee students. She

then has the students listen to them on a machine that has variable speeds, so the students can slow the tape down if they need to.

If you have other suggestions, or know of some listening materials you can recommend, do let us know! Thanks!

And computer software?

Ⓢ Gwen Gunnell would like to know if anyone can recommend computer software for ESL. She is interested in something that would not involve too much expense for her program, but which would give the students some additional challenging practice.

Fellow Nebraskan

Ⓢ We were delighted to hear from Marion Kistler, literacy volunteer in Tennessee. It turns out she grew up in Nebraska, just a few miles from our new location! (We suspect maybe she likes the winters better in Tennessee. . .)



A periodical for teachers and tutors of adult ESL

P.O. Box 256
Crete, NE 68333
USA

BULK RATE
U.S. POSTAGE
PAID
CRETE, NE
PERMIT NO.256

ADDRESS CORRECTION REQUESTED

September/October issue



Hands-on English

A periodical for teachers and tutors of adult English as a second language

Grammar grab-bag: "The places I've been"

Present perfect with "been"

This activity is simultaneously a grammar practice session and a conversation activity. Students get a chance to talk about themselves and interesting places, while becoming more and more familiar with a common English use of the present perfect.

How to do it

Start by writing the question "Have you ever been to Mexico City?" on the board, and ask several students the same question as a demonstration. Make sure they know how to answer with "Yes, I have," or "No, I haven't."

You can tell them that this lesson is about the present perfect, but no fancy grammar explanation is necessary at this point. This structure seems to be best learned by using it.

Before copying the sheet on page 3, you may want to add a few interesting places to the list. Or, you could give the students the handout as is, and have them add some places.

Survey

Tell the students they will be conducting a survey about people's experiences. Have them sit together in pairs and begin the survey. You can set a time limit so the students know what to expect, but don't make it too short—you want them to enjoy some conversation also.

You can circulate quietly and help with any problems the students have. Have them switch partners when the time is up and repeat the questionnaire.

Follow-up

An excellent conclusion to this activity is to have each student write some sentences about

one of the people he or she interviewed. For example: "Kim has never been to Mexico City." You might have to demonstrate some of the structures for them first.

Tutors, too

This activity was designed to be useful for the tutor working with one student, as well as for a class. You and your student can interview each other. Then, give the student a fresh copy of the survey form and ask him or her to interview two other people.

The student might interview a neighbor, a friend at work, a fellow student, or another teacher or tutor. In your next session, the student can give you a survey report.

(See page 3 for the survey form.) ←

Contents

Grammar grab-bag:	
- Survey with "been"	3
Minigrants award winner:	
-The YWCA Pizza Restaurant	4
On the market:	
-Reviews of 2 ESL books	7
Tools & techniques:	
-Multi-level dictation	8
Hints & tips	10
From the field:	
-Using volunteers in class	11
Editorial:	
-How do you feel about bad sounds?	12
News & notes	13
"Nightschool" -an ESL cartoon	13
Letters	16

Hands-on English

Volume III, Number 4
November/December 1993

Hands-on English (ISSN 1056-2680) is published six times a year (Jan./Feb., March/April, May/June, July/Aug., Sept./Oct., Nov./Dec) by Hands-on English, P.O. Box 256, Crete, Nebraska 68333 USA. Printed by Precision Printing, Crete, Nebraska.

Copyright © 1993 Hands-on English

Subscription rates: \$16 for regular subscribers, \$10 (discounted rate) for volunteers or teacher's aides, \$22 (multi-user rate) for libraries or institutions. Postage & handling: Canada and Mexico add \$4; outside N. America add \$10. Single copies of back issues are \$4 each.

Permission to photocopy: This periodical is copyrighted. However, we invite teachers and tutors with a paid subscription (or whose institution has a paid subscription) to make as many copies as they need for their own classroom use. (Please don't make copies for colleagues! We survive on subscriptions.)

Editor: Anna Silliman
(M.A., Teachers College Columbia U.)
Consulting Editor: Karen Campbell
Cartoonist: Michael Capurso
Grants Manager: Peter Dowben

Address correspondence to the editor at:
Hands-on English
P.O. Box 256
Crete, NE 68333 USA
Phone/fax (402) 826-5426.
Toll free call-in: 1-800-ESL-HAND

Subscribe today!

Send this form with your check or money order (U.S. funds only) to the above address.

About the publication

Hands-on English is a small, independent publication that was started in 1991. The editor is a former ESL teacher who has taught ESL in many settings, including adult education programs, a refugee program, community college, and a university intensive English program. . . and survived to write about it.

Articles and ideas are contributed by experienced teachers and tutors, including our readers. If you have an article or teaching suggestion you would like to share, we welcome your input!

About the Minigrants program

Hands-on English awards a few small grants (of \$100 each) annually for practical classroom projects. Applications are due April 30, and are available upon request.



Your editor . . . trying to look busy for the camera!

Please send me a subscription to *Hands-on English* for one year (6 issues). I enclose:

- \$16 **Regular teacher rate**
Permission to photocopy for teacher's own class(es)
 - \$10 **Discounted rate** for volunteers or aides
Permission to photocopy for your own student(s)
 - \$22 **Multi-user rate** for organizations
Permission to copy for multiple teachers/tutors
- _____ Postage/handling: Canada/Mexico add \$4.
Countries outside N. America add \$10.

Name: _____

Address: _____

Institution: _____

Position: _____

Check one: New subscription Renewal

11-4

Survey: Ask two people about their experiences. Write yes or no in each box.

Example: Have you ever been to Mexico City?

—Yes, I have.

Oh, that's interesting. Tell me about it.

Places	Name:	Name:
Mexico City		
a baseball game		
a soccer game		
a small birthday party		
a large department store		
a farm		
a political meeting		

★ Minigrants Award winner '93: The YWCA Pizza Restaurant

Joyce Grane teaches adult refugee students at the YWCA Intercultural Service Center in Tulsa, Oklahoma. She sends us this report on her award-winning project. As you will see, this activity serves several purposes for the students: they practice some job skills, they learn about American foods, they learn some shopping skills, they practice their English, they have some fun, and they gain in self-esteem from managing a project. Here's what happened:

The kitchen helpers arrived around 6:00 pm and began washing the vegetables, chopping, slicing, opening and draining cans and cutting the bread. The toppings they had selected (green peppers, mushrooms, olives, tomatoes, pineapple, pepperoni, hamburger, cheeses, and tomato sauce) were assembled in bowls.

The manager gave instructions to the new staff and quickly answered all the questions, such as, "How do I cut this?" "Do we use all of the mushrooms?" and "How does this can opener work?"

All the employees were selected and they each put on a job label.

Teamwork

At 6:35 The kitchen staff joined the busboys, setting up the tables, putting on the one tablecloth, pouring the ice into the chest, opening and setting out the soda bottles, arranging the chairs, etc. with ease, cooperative effort and expertise.

At 6:45 the kitchen staff went into the kitchen. The cook donned his apron (bright yellow and a little too small) and began locating the baking sheets, knives, and large spoons. Meanwhile the staff arranged the bowls of toppings on the counter. They briefly reviewed the menu and the stove was examined and turned on.

The waiters and waitresses arrived and picked up the pencils and papers. After a quick review of the menu and the role-playing dialogue, they stood nervously at their places.

The curtain goes up

Promptly at 7:00 pm, August 2, 1993, the host, Manh Pham, with a gracious smile on his face and a stack of menus in his hand, proudly

opened the door of the YWCA Pizza Restaurant for the customers, who happened to be Job Links Refugee VESL Program students. He seated the customers, and the waiting staff went to work.

As the evening progressed, some of the customers began to realize that, although they had been efficiently served with the drink of their choice, the pizza of their choice was never going to appear before them since their waiter/waitress had (as in so many American restaurants) disappeared.

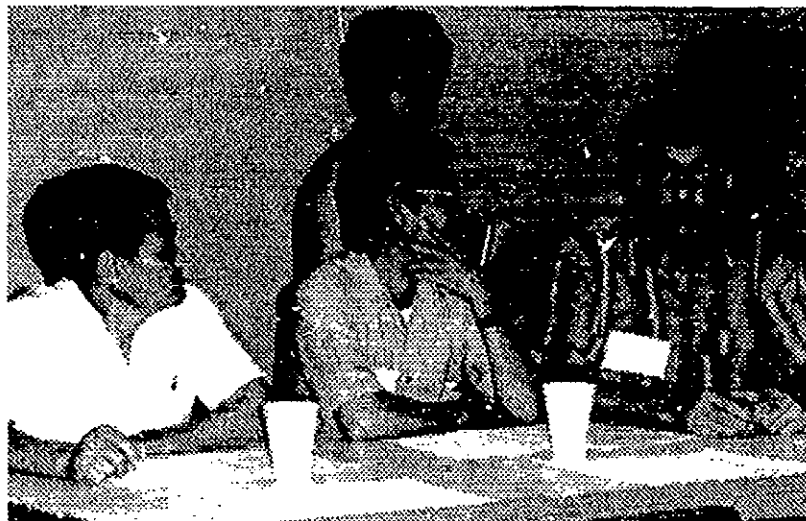

"Hmm. . . maybe we should have gone to Burger King instead."

Soon, however, the kitchen staff became more enthusiastic (and hungry) and with great teamwork and cooperation eagerly filled all the baking pans with whatever toppings were at close reach and finished baking all the pizzas. They then quickly joined the customers to enjoy the feast.

A special event

The highlight of the evening was the presentation of a large birthday cake which had been hastily ordered when a student announced the previous day that he had a birthday pending. After he blew out all his twenty-eight candles, everyone sang *Happy Birthday* and enjoyed the cake.

Innovative technique

Within twenty minutes, promptly at 9:00, the cleanup crew transformed the restaurant back into the YWCA gymnasium, cleaned up the kitchen, and placed all the dirty baking pans,



The hard-working cooks

Getting it ready

In preparation for the YWCA Pizza project, the VESL evening class had spent the last two weeks of July examining menus from pizza restaurants and preparing their menu. The students discussed the possible toppings and names for the individual bread pizzas they would be preparing. They discussed the prices of the food, and were delegated the responsibility for some comparative bargain shopping.

The students easily identified all the restaurant employees and the responsibilities of each job. They created dialogues for the waiter/waitress, and the role-playing was fun for all. Job labels were prepared. Volunteering was

heavily weighed on the side of kitchen helpers and busboys, but no commitments had to be made before the restaurant opened.

Over this two week period, the announcement board (at the beginning of each class period) included the invitation to all for the FREE Pizza Restaurant.

(See the MENU for this event on the next page.)

bowls and spoons into the trunk of the white Toyota which they knew belonged to the teacher. They explained that the dishwashers never showed up!

Here is the comparative shopping form the students used to prepare for the project:

DATE: 7-26-93

COMPARATIVE SHOPPING		HOMELAND		
PRODUCT NAME	STORE NAME	QUANTITY SIZE	PRICE	PRICE SALE
Lindsay Pitted Olives Medium	HOMELAND	6 OZ	1.59	\$ 1.59
Solo party cup		50 - 9oz		\$ 1.64
Best buy (paper plates)		9 inch		99¢
Dixie colored party cup		24 - 9oz		66¢
Northern napkin		250 pieces		\$ 1.69
napkin		120 pieces		79¢
ice				\$ 79¢

ESL
YWCA Fizza Restaurant
17th & Memorial
Tulsa, Oklahoma
(918) 628-1030

*Now serving free pizza—August 2nd
in the YWCA gym, from 7pm. to 9 pm*

*Made by the ESL students
YWCA Intercultural Center*

MENU

1. ASIAN DELUXE (pineapple, pepperoni, mushrooms, cheese and olives)
2. MEXICAN SUPREME (tomatoes, beef, cheese, green peppers and olives)
3. MID-EASTERN VEGETARIAN (green peppers, mushrooms, tomatoes, pineapple, extra cheese and olives)
4. AMERICAN PIZZA (beef, pepperoni, extra cheese, mushrooms and tomatoes)
5. YWCA SUPREME (all toppings)

Or create your own pizza!
Choose from the list of toppings the pizza you would like to eat.

Enjoy our home-made pizza.

SOFT DRINKS
Coke, Orange and Dr. Pepper

On the market

Reviews of useful ESL materials

"More Index Card Games and Activities for English" by Raymond C. Clark (1993 Pro Lingua Associates, 15 Elm St, Brattleboro, VT 05301 USA). \$12.95. ISBN 0-86647-075-1.

We're constantly on the lookout for books that will help you expand your teaching repertoire with useful activities for your students. In the past, we have mentioned "Index Card Games for ESL" as one such book; now the same author has come out with this second book which proves to be just as useful.

The book describes nine kinds of activities you can do with cards, and within those there are plenty of suggested variations, so it is a rich source of teaching ideas. These are the kind of activities that will blend in well with your current class work—you can use them to reinforce vocabulary or practice and expand on speaking and listening skills.

Adapting to your needs

Each game comes with an example which, if appropriate for your students, you could copy and use. (Warning: those cards labeled "easy" may be too difficult for real beginners.) But each game also comes with lots of suggestions for adapting the activity to a lower or higher language level, how to use it with mixed level groups, and best of all, lists of different topics that will work for that game.

We especially like the **Cue Cards** activity (each student gets some factual information on a card and has to explain it to another student) and the **Patter Cards** (small structured conversations that students can practice, then develop further).

Once you have chosen a game you would like to try with your students, you might find yourself spending some time preparing cards that are suitable for your students' language level and interests—in our experience, the more thought you put in to activities like these, the better they work.

Tutors, too

Both new and experienced teachers could make use of these ideas. The step-by-step instructions are clear and thorough, explaining both how to do the activity and why it is useful. And because many of the activities are done in pairs, they would work well in one-on-one tutoring sessions also. ☛

—Anna Silliman

"LifePrints: ESL for Adults" by Robert Ventre Associates, with Allene G. Grognet and JoAnn Crandall (1993 New Readers Press, Box 131, Syracuse, NY 13210). Book 1 reviewed here; books 2 and 3 soon to be available. Student book \$8.00 (ISBN 0-88336-0349), Teacher's Edition \$12.00, Resource File \$60.00. Audiotapes.

In a better world, all of our students would get a two-year intensive course in English that would lay the foundation for the acquisition of advanced language skills. Since that is still not the case, and many are lucky to get even six months of part-time instruction, they'd better get as many of the most necessary skills they can—which *LifePrints* can help them do.

This program for low-beginning level adult ESL students might be used in an environment where survival skills or pre-employment skills are taught, such as a refugee program. It covers important adult issues such as going to the doctor, dealing with the post office, applying for jobs, shopping, finding an apartment, etc., and does so in a serious and realistic way. Although material like this is available from many other sources, *LifePrints* brings it all together in one very thorough book.

The book's format is a very good feature—it presents a group of realistically drawn characters (including Asians, Hispanics and a black family) whose stories recur from chapter to chapter, so that students become familiar with them as people. The appearance of the book is very nice and uncluttered. A bad aspect to the book is that grammar concepts are not systematically presented.

The materials available to the teacher or tutor in the Resource File are very complete, and offer pages and pages of worksheets, games, activities and teaching suggestions as follow-up to each lesson in the Student's Book. In fact, these materials could practically provide a crash course in how to teach survival ESL. The wealth of activities are probably more than you would use, but would give you enough back-up material to use as reinforcement if needed.

The real achievement of this book is to make it possible for inexperienced instructors and tutors (even those with no background in teaching ESL) to walk in and help the students learn English. It is not, however, intended for multi-level classes, and does not solve the problem of teaching pre-literate students (these would still need additional materials and a different pace of learning). ☛

—Anna Silliman and Marcia Hannett

Hands-on English, Vol. III, No. 4

Tools & techniques: Multi-level dictation

Cloze? Cloze who?

A "cloze" exercise was originally designed as a reading test. If students could understand a passage with, say, every 5th word missing, then you would know they were reading successfully at that level.

But ESL teachers now use a "cloze" exercise just for language practice. It works well because it helps students to focus on a few limited language features at a time, without being overwhelmed with everything at once.

For example, you could give the students a paragraph with all the verbs missing, or with all the prepositions missing, etc., depending on what you want them to practice. If they have understood the meaning of the passage, they should be able to insert a word that makes sense in that context.

'Cloze' your eyes and listen

Here is an example for you of a "cloze" exercise for listening practice. It is actually just a simplified dictation, but at three different levels.

How to do it

Give each student a copy of the worksheet that you think is most appropriate for his or her level. **A** should work for beginning-level students, **B** for intermediate, and **C** for more advanced students. (If you have a really advanced student, he or she could try the

dictation with no help at all, or with a sheet only of blanks (use white-out on a copy of level C to prepare this). You may want to enlarge the text on your copier to make it easier to write.

Before the students turn over the sheet to look at it, have them listen while you read the passage at natural speed. Next, have them look at the page while you read the second time, also at natural speed. On the third reading, they can start writing in missing words as you read.

It is best if you keep to a natural speed, but leave longish pauses at natural breaking points, such as the end of a sentence, for students to write. You can repeat the passage as many times as the students want you to, though. Once the students are finished, they could help each other to correct their papers. (Try pairing advanced students with beginners for the correction, because each will have information the other needs!)

Adapting for your students

You can prepare a similar exercise for your students from any appropriate text. One piece of advice: The activity is much more useful to the students if you use a paragraph they have seen or read before—say, a text from last week's lesson. Having some familiarity with the content will give them a better chance of succeeding. Nonetheless it will still be a challenging exercise, and will provide some review at the same time. ➔

The text for dictation:

Many people are talking about health care right now. Americans are worried because health care costs are rising in the U.S. Medical insurance is expensive, and many people do not have insurance at all. Even people who have insurance are afraid of losing their job, or afraid that an illness would cost them everything they have. Many countries in the world have a different system for health insurance. Lawmakers are planning to change the U.S. system soon.

A Many people are _____ about health care right _____.
_____ are worried because health care costs _____ rising in the _____. Medical insurance is _____, and many people do _____ have insurance at all. Even people who have insurance are _____ of losing their _____, or afraid that an _____ would cost them everything they have. Many countries in the _____ have a different system for _____ insurance. Lawmakers are planning to _____ the U.S. system soon.

B Many people _____ about health _____ right _____. Americans are _____ because health care _____ are rising _____ U.S. _____ insurance is _____, and _____ people do not _____ insurance at all. Even people who have _____ are afraid of losing their job, or _____ that an _____ would cost _____ everything they have. Many _____ in the world have a _____ system for health insurance. Lawmakers _____ to change the U.S. _____ soon.

C _____ people _____ about _____ right now. Americans _____ health care _____ in the U.S. _____ insurance _____, and _____ people _____ insurance _____. Even people _____ insurance _____ losing _____ job, or afraid _____ an illness _____ everything _____. _____ in the world _____ different _____ health insurance. Lawmakers _____ the U.S. _____ soon.

Hints & tips

Have you got an idea that works for you? Maybe you'd like to share it with other readers! ESL teachers and tutors are always looking for ideas to try out with their students.

Sharing a classroom

Many evening classes for adults meet in public school facilities, and so share a classroom with daytime students. This can lead to tensions, particularly if the children feel their space is being invaded. One of our readers, Deborah Lazarus Yarzagaray, wrote a lovely article about creating a penpal program between her adult students and the fourth graders whose desks they shared, and how both groups of students learned from each other.

The communication started when some of the fourth graders left notes warning the adult education class not to touch their stuff. In response, the adult students wrote letters of introduction about themselves. The fourth-grade teacher gave each of her students one of the letters to read, and the children wrote replies. Soon an enthusiastic correspondence developed, and the two groups became friends.

*The above-mentioned article was published in the Fall 1993 issue of the New York State TESOL newsletter, the **Idiom**. If you'd like to read the whole article but don't have access to that publication, drop Hands-on English a note and we'll send you a copy.*

Listening materials

This hint comes in response to reader Mauritzia Liriano's search for good listening materials, which we mentioned in our last issue:

"I like to tape radio announcements that are appropriate. I especially like dramatized dialogues where the speech is distinct and the vocabulary and structure familiar and useful. I make a typescript and use it for reading and role-play practice.

"You can make cloze exercises also. In addition to giving practical listening exercises, this encourages the students to listen to the radio themselves."

—Gail Boehme, Santa Barbara, CA

(Note: See an example of a "cloze" exercise—a short text with words missing—on page 8.)

"Composite biographies"

This activity works well to fill the last five or ten minutes in a class. You need some large pictures of interesting-looking people.

Displaying one picture at a time, the students generate an imaginary biography about the person. This can be done by opening up the discussion to the entire group with students contributing information as they choose. If one student dominates the activity, you can have every student make one statement about the person in the picture, so everyone gets to contribute an idea.

Emphasize that the information must agree with what has been previously stated, so the biography will make sense. It often helps to jot down general information about the person on the board to help students refer to what has already been said.

—Cathy Yorio

—Marge Volpe

—Jennifer Brown, Rochester, NY

(From their 1992 conference presentation on using pictures in ESL.)

Tutors, too

Working with just one student can be limiting—sometimes it's nice to have another person to practice with. Here's how to get one. First, try the biography activity (see above) with your student, and write a biography together about this imaginary person. Then in future sessions, bring the picture along and display it in the room.

Use this "person" as someone to talk about when you need examples of the third person (ie, "Does he have a car?") or just for when you get tired of talking about yourselves all the time (ie, "Tell me about his job"). You can also use the picture as someone to talk to when you get tired of asking each other questions (ie, "Ask him if he knows what time it is.).

If you don't bring the picture to one session, you and the student can have fun discussing why your imaginary person didn't come today. Having an imaginary character in your "group" will add a new dimension to your sessions, and will allow for more flexibility in language practice. ←

From the field:

Volunteers for in-class support

Hands-on English recently relocated to Nebraska, so we thought it would be a good idea to visit some programs here to learn what's going on in ESL. We started with one close to home—the Adult Education program in Crete, our adoptive home town with a population of 5,000.

We visited the evening ESL classes of the Crete Adult Education program. This part of their program has three part-time ESL teachers who teach two evenings a week, from 7 to 9 pm. Currently most of the students are either Vietnamese or Hispanic. Classes meet in the high school building. Does this sound familiar? The set-up is similar to many adult education programs everywhere in the country.

Small groups

The first thing we noticed was that the classes are not too large, so the instructors have a chance to give students individual attention. In fact, the students seemed to know the staff and teachers at the school quite well, and hung around talking with them both before and after class. The atmosphere was relaxed and comfortable.

Volunteer helpers

The aspect of the program that caught our interest, though, was the use of volunteers in the classes. One of the volunteers was a Vietnamese man who spoke excellent English. During the evening he circulated between classes, apparently in order to offer assistance to any of the Vietnamese students in each class who might need it.

Another volunteer was an American woman who joined the beginning-level class. On that particular evening she sat next to a student who had just enrolled. While the teacher gave the lesson, the volunteer spoke quietly with the student, apparently assisting and explaining to him what was going on. On one occasion she asked the teacher a question on the student's behalf; another time she repeated an answer the student had given, but more loudly so the whole class could hear it. In this way, a shy new student got credit for a good answer.

We thought that integrating volunteers right into the class-work was a nice way to create a supportive atmosphere, particularly for new students. We were told that it also works well for students who come in at a lower level. They still get to hear what the other students

are doing in class, but receive some extra help from the volunteer until they gain more expertise in English.

This kind of support from a network of helpers sends a message to students about the program—that people here care seriously about your learning.

How they do it

We spoke with Vicky Bauer of the State Education Department in Lincoln, Nebraska, who told us that volunteer support is typical for adult ed programs in Nebraska. She explained that each local program usually has a volunteer coordinator, who receives special training for the job. Also, activities for volunteers are integrated into ABE conferences and staff development workshops so these helpers can really be part of the overall program.

Sources of recruits for volunteers might include: local colleges and universities (for practicum students as well as regular community action volunteers), literacy organizations, church groups, civic groups, women's clubs, United Way organizations, and even high school students (sometimes they can do community projects for credit in school).

If you would like to start this system for your program, some attention will have to go into publicizing the need for volunteers, especially at first. You can stress that what is needed are good models for English, and that special teaching skills are not required. A good argument to include in your publicity is that the process provides the volunteer with a wonderful opportunity for a multicultural experience. ↩

Be a roving reporter!

If you see something interesting going on in an ESL class or tutoring session, why not write to us about it? We'll pass it along to our readers, who like to hear about what others are doing.

(By the way, if you are reporting on another instructor's work, don't forget to ask permission before passing along their ideas to us.)

Please include your telephone number, and best time to call, in case we have some follow-up questions. Thanks!

—the Editor

Editorial: Bad sounds?

Teachers and tutors have often asked us how to improve their students' pronunciation. Although we can think of lots of ways to approach this problem, our ideas don't always work in practice.

A matter of taste

One factor we believe to be important is this: Does the student like the sounds? Perhaps it is easier to imitate sounds if you like them. If you dislike certain sounds, why would you want to make them correctly?

Here's an example of this taste factor—Americans speaking the German language have trouble making the German *r* sound correctly. Germans can recognize an American speaker solely on the basis of this incorrect *r*. On the other hand, ask any American how the German language sounds, and they will answer "guttural." Now, "guttural" is a very negative description, associated with angry, animalistic sounds. Not only that, but these "guttural" sounds are associated in American minds with the Nazis they have seen portrayed in film and on T.V. Is it any wonder that Americans would hesitate to adopt this disgusting sound?

A similar example regards our English *th* sound, which German speakers find particularly difficult to use correctly, often substituting an *s* sound instead. This editor spent several years teaching English in Berlin, and tried all kind of methods to correct this problem with her students—videos, tapes, demonstrations, drills, diagrams, charts, jumping up and down, praises, threats, and prizes—nothing really worked.

Then one day while having coffee with some friends, we heard a native German speaker make several perfect *th* sounds in a series of 4 or 5 sentences. The context? He was making fun of somebody and was imitating a baby's lisp. It appears that to an adult German speaker, our *th* sound seems babyish, and is embarrassing or even insulting to use. Is it any wonder they often fail to use it?

Blow, blow!

The same subconscious factor may be true of other pronunciation problems we observe in our classes. For example, if you have Vietnamese students you know that they often have difficulty pronouncing *p*'s and *f*'s correctly, making a quiet sound instead that falls somewhere in between. But if you listen to these students

speaking Vietnamese, you may notice that their language doesn't have fricatives (that is, 'blowing' sounds), or at least not ones as forceful as ours. Can it be that these 'blowing' sounds seem rude to the Vietnamese? Perhaps it doesn't seem polite to them to make blowing, spitting sounds in someone's face.

This would certainly explain why no amount of our explaining and demonstrating seems to result in correct pronunciation! Students will appear to understand the concept, succeed at making sound correctly once or twice, then giggle nervously and go back to the more comfortable mispronunciation.

Bad sounds, bad vibes

The way things *appear* to sound—that is, the emotional content we attribute to the sound—may affect our willingness to imitate them. Perhaps mispronunciations are a way to protect ourselves from something we mistrust.

Be like me

One of the reasons younger people (under the age of 14) succeed better at acquiring accent-free English may be that they are eager to change themselves and become part of something new. They are also more likely to have English-speaking friends that they like and want to imitate. Older people don't want to give up their manners and their personalities, and so don't enter as easily into different ways of sounding.

As instructors we have to recognize that there are several processes involved in learning correct pronunciation. One is learning to recognize a new, foreign sound. Another is to learn how to make it correctly. Another is to remember when to use it. A further process, we are suggesting, is to overcome the natural reluctance to use it.

How can the instructor help with this? One way is by providing the friendliest, most supportive possible environment for the student—one in which no one is ever ridiculed for the sounds he or she makes—so that students will feel invited to try. The other thing we can do is de-emphasize the importance of specific sounds (after all, some accent is acceptable in our culture) and spend more time teaching the correct rhythms, intonation and stress patterns of English, which may be more helpful overall in producing natural-sounding speech that is easy to understand. ☛



Upcoming conferences

◆ November 20-22, 1993—**American Council on the Teaching of Foreign Languages (ACTFL)** annual conference in San Antonio, Texas. Contact ACTFL, 6 Executive Plaza, Yonkers, New York 10701.

◆ November 30-Dec 1, 1993—**Center for Workforce Education (CWE)** Education Seminar in Cincinnati, Ohio. 1-800-221-6676.

◆ December 1-4, 1993—**National Reading Conference** 43rd annual meeting, in Charleston, South Carolina. 312-329-2512.

◆ December 7-8, 1993—**Center for Workforce Education (CWE)** Education Seminar in Boston, Massachusetts. 1-800-221-6676.

◆ December 11-13, 1993—**American Reading Forum** at Sanibel Island, Florida. Contact Terry Bullock, 513-566-1765.

◆ December 27-30, 1993—**Modern Languages Association of America (MLA)** annual conference in Toronto, Canada. Contact MLA, 10 Astor Place, New York, New York 10003.

The new "Hands-on"

Notice anything different about this issue? Yes, indeed, we are expanding to 16 pages. We're delighted to be able to bring you even more good stuff in every issue, at no extra cost!

This is possible in part because of our increasing circulation. Many thanks to those of you who have been helping to spread the word about Hands-on English!

More News & Notes... see next page

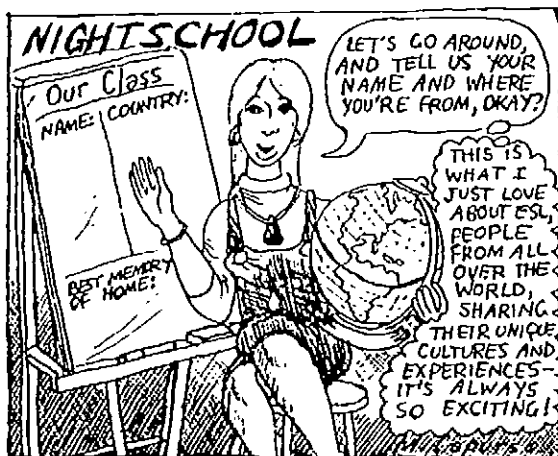

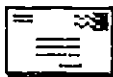

...continued from page 13.

Sa-i-Gu

"Sa-i-Gu" means April 29th in Korean, and is the title of a film that was shown on public television late in September. April 29th, of course, was the date of the 1992 Los Angeles riots. The film shows the experiences of three Korean women, their sorrows and pains as their American dream, along with their businesses, was destroyed in one night.

A fascinating and complex story, the film suggests that the typical American dream of so many immigrants (working hard and taking care of your own) is in crisis, and needs to be re-examined. Immigrants will need to take a greater role in the community around them in the future. The film raises issues of racism, both of the American society toward the Koreans and of the Koreans themselves toward black Americans.

Hmong portrait

An artist/oral historian in Green Bay, Wisconsin has launched a unique project she calls "an aesthetic documentation of the Hmong refugee elders here within my community." The project includes large-scale drawings of the individuals, documentary photographs of their everyday lives, and their first person narratives recounting the journey that brought them here, so far from home.

A Portrait of Grief and Courage will be on display at the Brown County Central Library in Green Bay. The artist continues to work on the project and would welcome information about funding sources to support the work. She is: Sandra Shackelford, 1373 Eliza St., Green Bay, WI 54301 USA.

Medical curriculum can be fun

If any of your students are studying for nursing or health care professions, you may want to know about this interesting new teaching material. Called *Mary's Story: A Curriculum for Teaching Medical Terminology*, it uses a story form to help learn and reinforce medical vocabulary.

The materials were developed for adults who read at the 5th to 8th grade level. The vocabulary is appropriate for licensed practical nurses, nursing assistants, geriatric nursing

aides and home care aides. The project was funded by a grant from the Pennsylvania Department of Education.

The material includes a 78-page narrative, a 13-lesson student activities booklet, teacher and student guides, and pre- and post-tests. It is available for \$28 from the Institute for the Study of Adult Literacy, 204 Calder Way, Suite 209, University Park, PA 16801 USA. Tel: 814-863-3777.

Depressing news

A Department of Education report finds that 40 million Americans are functionally illiterate, and that all of the adult education programs combined (LVA, Laubach Literacy, ABE programs, etc.) serve only 10% of these people.

Science news

Scientists have discovered a new element, called *administratium*. The heaviest element known to science, this material is almost impervious to change. The element occurs naturally and can be found on school campuses, large corporations and government centers; usually in the best-maintained building.

At the present time there does not appear to be any practical use for *administratium*. Observations of the element show that it appears to do nothing at all, most of the time. ↩

*Happy Holidays
to you
and your students
from
Hands-on English*



by
**Anthony
Mollica**

Illustrations:
Nancy Elkin

10 familiar themes
80 line-master puzzles for reproduction
200 high frequency words

Line Masters for Reproduction*

- | | |
|--|---|
| ✓ for fun and relaxation | ✓ for reviewing high-frequency vocabulary |
| ✓ an alternative to translation, definition or description | ✓ direct association between language and image |
| ✓ are excellent for the early stages of language learning | ✓ are great for the visual learner |

Themes

- | | |
|----------------------------|-------------------|
| 1. At School | 6. At the Farm |
| 2. Sports | 7. At the zoo |
| 3. Activities | 8. In the Kitchen |
| 4. Articles of Clothing | 9. Fruit |
| 5. Means of Transportation | 10. Vegetables |

* Reproduction rights are granted only for the classes of an individual teacher purchasing these materials. Any further reproduction or different use without the written permission of the publisher is an infringement to the copyright law.

editions **SOLEIL** publishing inc.

P.O. Box 890, Lewiston, NY 14092-0890
Tel. / Fax: (905) 788-2674

EDUCATIONAL SHOWCASE

Your ESL Connection

Providing ESL/EFL Programs for All Ages
The Largest Collection of ESL Materials
on Display in the Midwest

- * Place orders by mail or fax: (313) 680-1052
- * UPS delivery in 5 to 10 days of in-stock items
- * We meet publisher's prices AND beat the service
- * To order or to receive our comprehensive ESL catalog write to:



EDUCATIONAL
SHOWCASE
1334 Wheaton Street
Troy, MI 48083
(313) 680-0860

Classified ads

To place a classified ad, send your notice of 30 words or less with US \$10 (subscribers get a discount of 50%) to: Hands-on English, P.O. Box 256, Crete, NE 68333 USA. Phone/fax: (402) 826-5426. Toll free call-in: 1-800-ESL-HAND.

Publications:

Now available—THE ESL LOCATOR:
Sal Parlato's updated guide to 1,200 national ESL organizations. Prepaid \$11.50 (includes S&H) from TESOL, Booklink, or from: Dolores Parlato, 248 Seville Dr., Rochester, NY 14617.

Back issues of *Hands-on English* are now available at US \$4 per copy (this includes shipping costs). Let us know which issues you're missing! See our address above.

Letters



Talking about crime

Dear Editor,

This is in response to your question concerning talking about crime in the Sept/Oct issue.

I have talked about this problem during my last three tutor training workshops. While discussing 'Intercultural Communications and Culture Shock,' I show the trainees the attached article from the New York Times, and we discuss its implications. (*Editor's note: The article describes misunderstandings that occur for Japanese who have learned faulty English in school. Many Japanese now enroll in "Defensive English" courses before travelling to the U.S.*)

Because of the shock-value of the killing of a Japanese student who didn't understand the word "freeze, the lesson learned tends to stay with the trainees once they start tutoring. Hopefully, this will make them more sensitive to the problems their students encounter in a strange country.

—Harry Scher, Englishtown, NJ

Overseas teaching?

"Could you put me in touch with anyone who could give me information about possibilities for teaching overseas? Thanks."

—Diane Ernst, Gillette, WY

We hope some of our readers will have ideas or experiences they can share with Diane. In the meantime, we ran across two books that might be helpful to anyone planning such a venture:

Teaching English Overseas: An Introduction by Sandra Lee McKay (1992 Oxford University Press, 800-451-7556) ISBN 432814-7, \$12.95.

Teaching EFL Outside the United States, 1993 by TESOL (1600 Cameron St., #300, Alexandria, VA 22314 USA. 703-836-0774) \$22.

And if you decide to do it, you might want to look into this book:

Moving Your Family Overseas by Rosalind Kalb and Penelope Welch (1992 Intercultural Press, Inc., P.O. Box 700, Yarmouth, ME 04096 USA. 207-846-5168) ISBN 1-877864-14-5, \$14.95 ↵



A periodical for teachers and tutors of adult ESL
P.O. Box 256
Crete, NE 68333
USA

BULK RATE
U.S. POSTAGE
PAID
CRETE, NE
PERMIT NO.256

ADDRESS CORRECTION REQUESTED

November/December issue

206



Hands-on English

A periodical for teachers and tutors of adult English as a second language

Discussion topics: Talking about schools

In this issue we bring you a crossword puzzle and a reading passage about U.S. schools (see pages 8 and 9) which we hope your students will enjoy. This topic may be interesting to them personally—either because of their own further education or their childrens’—and it is interesting also as a current topic of debate in the media.

Here are some suggestions for enhancing your discussions.

Alternative Ed

Read the passage on page 9 with your students. Supplement this information with a discussion of the GED—what it is, where it fits into the system, what a ‘drop-out’ is, etc. If your students might want to pursue a GED someday, find out where they can do this and what the requirements are. If your program is connected with an ABE program, it shouldn’t be too hard to locate a GED graduate to come and talk with the students.

Review any other educational opportunities that are available to your students and the process for enrolling in them.

Guest speakers

Invite the principal of a local school to visit your class and talk with the students. (Have the students prepare some questions beforehand.) You could also arrange a tour of a local school by the principal or a school official. This way, the students will have a chance to practice their English, meet and talk with an important member of the local community, and get answers to questions they are concerned about.

Other issues

In this country, because most schools are controlled locally, the role of the individual relative to the school is likely to be different

from what your students are accustomed to. Community members have more “say” in educational issues than in many other cultures, and they also have more responsibility. The more they can learn about this the better they will be able to participate in this society.

Some topics to discuss include: the role of student governments in high schools and in higher education; the role of school boards and the influence community members can have; the role of parent-teacher organizations; the practice of parent/teacher conferences.

Students should learn that it is acceptable, even expected, that they ask questions of educators, particularly about what their children are doing in school. ↵

Contents:

Letters	3
Grammar grab-bag:	
–Using nouns with no article	4
Minigrants award winners:	
–“The wonderful world of wood”	6
–“A video activity”	11
Crossword puzzle:	
–Puzzle on the U.S. school system	8
–Reading and discussion	9
Writing activity:	
–Commemorative poems	10
Editorial:	
–Adult ESL is on the fringes	12
Hints & tips	12
News & notes	13
Announcing. . Minigrants 1994	14
“Nightschool” -an ESL cartoon	16

Hands-on English

Volume III, Number 5
January/February 1994

Hands-on English (ISSN 1056-2680) is published six times a year (Jan./Feb., March/April, May/June, July/Aug., Sept./Oct., Nov./Dec) by Hands-on English, P.O. Box 256, Crete, Nebraska 68333 USA.
Printed by Precision Printing, Crete, Nebraska.
Copyright © 1994 Hands-on English

Subscription rates: \$16 for regular subscribers, \$10 (discounted rate) for volunteers or teacher's aides, \$22 (multi-user rate) for libraries or institutions. Postage & handling: Canada and Mexico add \$4; outside N. America add \$10. Single copies of back issues are \$4 each.

Permission to photocopy: This periodical is copyrighted. However, we invite teachers and tutors with a paid subscription (or whose institution has a paid subscription) to make as many copies as they need for their own classroom use. (Please don't make copies for colleagues! We survive on subscriptions.)

Editor: Anna Silliman
(M.A., Teachers College Columbia U.)
Consulting Editor: Karen Campbell
Cartoonist: Michael Capurso
Grants Manager: Peter Dowben

Address correspondence to the editor at:
Hands-on English
P.O. Box 256
Crete, NE 68333 USA
Phone/fax (402) 826-5426.
Toll free call-in: 1-800-ESL-HAND

Subscribe today!

Send this form with your check or money order (U.S. funds only) to the above address.

Please send me a subscription to *Hands-on English* for one year (6 issues). I enclose:

- \$16 **Regular teacher rate**
Permission to photocopy for teacher's own class(es)
- \$10 **Discounted rate** for volunteers or aides
Permission to photocopy for your own student(s)
- \$22 **Multi-user rate** for organizations
Permission to photocopy for multiple teachers/tutors
- _____ Postage/handling: Canada/Mexico add \$4.
Countries outside N. America add \$10.

Name: _____

Address: _____

Institution: _____

Position: _____

Check one: New subscription Renewal

About the publication

Hands-on English is a small, independent publication that was started in 1991. The editor is a former ESL teacher who has taught ESL in many settings, including adult education programs, a refugee program, community college, and a university intensive English program. . .and survived to write about it!

Articles and ideas are contributed by experienced teachers and tutors, including our readers. If you have an article or teaching suggestion you would like to share, we welcome your input!

About the Minigrants program

Hands-on English awards a few small grants (of \$100 each) annually for practical classroom projects. Applications are due April 30, and are available upon request. ↵



Your editor, Anna Silliman, is looking forward to hearing from you! Call or write with your comments, suggestions, questions & ideas.

Letters



Praise from a volunteer

"I am the VISTA Volunteer in Yavapai County, Arizona, and I work with seven adult literacy programs in the area. I enjoy reading your publication, as do many others involved in adult literacy. *Hands-on English* is a wonderful source of ideas and support for the tutors and volunteers of the adult literacy programs."

—Melananie Hobbs, Camp Verde, Arizona

The Muse strikes again

We are constantly amazed at the talent of our readers! We absolutely must share with you two of the responses to our recent renewal notice:

"We love Hands-on English
It's wonderful stuff
Of this kind of info
there's never enough

It's important and topical,
clever and funny.
And so, we're renewing.
Enclosed is our money."

—Nena Kelty, Glendale, CA

Here's one in a different style (can anyone identify this verse form??):

Great magazine
Best that I've seen
to help new teachers like me
who look forward with glee
to each new issue.

—Brigid Dawson, New York, NY



More on overseas travel

*In our last issue, a reader asked for some information about teaching overseas. Sal Parlato, author of **The ESL Locator***, has kindly responded by sending us an article he wrote on this topic. Here are some excerpts:*

"Life 'over there,' although sometimes considered a fantasy world, is not a vacation with pay. *Au contraire!* Life abroad includes more than its share of day-to-day hassles. No, I'm not referring to ideological differences or Yankee-go-home sentiments. It's more a matter of adjusting to the culture shock of a foreign language, confusing currency, unfamiliar transportation, hasty housing, a different diet, limited entertainments and unconventional (possibly offensive) male/female relationships.

On the other hand, this temporary form of survival living will give you a special empathy for the adjustments your future ESL students must face when in the USA.

Some nations hire teachers of English via their embassies in Washington, D.C. If you have a particular country in mind, contact its Education Officer or Cultural Attaché there. Addresses should be available from your U.S. Congressman or from the new resource directory, **The ESL Locator***.

For more information about overseas opportunities, consult also Susan Griffith's book **Teaching English Abroad** (Patterson's Guides, P.O. Box 2123, Princeton, NJ 08542, tel: 1-800-338-3282). A similar reference is **How to Find Jobs Teaching Overseas, 2nd Ed.**, by James Muckle (KSJ Publishing Co., P.O. Box 2311, Sebastopol, CA 95473).

For a mini-directory of 36 U.S.-based employers, recruiters, and clearinghouses, please see 'Overseas Opportunities' on page 57 (and following) of **The ESL Locator***.

—Sal Parlato, Rochester, NY

Thanks, Sal—by the way, speaking of shock—how's the weather in Rochester? Be sure to write to us again next time the snowplows get through! ☞

* ordering information for **The ESL Locator** is on page 15 of this issue.

Grammar grab-bag:

"I'm not afraid of elephants or floods."

When to use nouns with no article

We recently received a phone call from Edith Kennedy, a literacy volunteer in Key West, Florida. She explained that there were a great number of Polish ESL learners in her area, many of whom shared a common difficulty with English articles (a, the, some, any, etc.).

These students had already studied count and non-count nouns, definite and indefinite articles, and plurals. They knew, for example, when to use "a" and when to use "the." However, in practical use they still had a lot of trouble knowing when *not* to use an article.

This may seem like a small problem, but actually it is a serious one, because it affects the meaning. For example, if we say: "Polish students have trouble with articles," we mean all Polish students (possibly because of the different grammatical structure of Slavic languages). However, if we say: "The Polish students have trouble with articles," we may mean specifically the ones in Key West, as opposed to the Spanish-speaking students there who do not have this problem.

This could be phrased as a rule—If you mean *all* of them in general, use no article. If it matters *which ones* you mean, use an article.

How to do it

Introduce this grammar concept (general vs specific meaning of nouns) by asking the students some questions about things they are afraid of. For example: Are you afraid of elephants? Are you afraid of thunder? Be sure to ask some questions that elicit specific answers, too, such as: Are you afraid of the elephants in the zoo?

Article or no article?

(Write \emptyset or the)

One day, two elephants walked into _____ ESL class.
_____ students were very surprised.

_____ elephants had long trunks and very big feet.
_____ students were frightened, because _____ elephants
can be dangerous.

But _____ teacher wasn't afraid. She picked up a big
dictionary, and she threw _____ dictionary at _____
elephants. _____ elephants turned and ran out of _____
room.

"I'm not afraid of _____ elephants!" said _____ teacher.
Then she called _____ police.

Write their answers on the board, grouping the general ones on one side and the specific ones on the other side. When you have several examples of each, ask students to identify a pattern. (They should notice that the general answers have no article.)

Now, give the students a copy of the 'elephants' exercise below, and have them work on it by themselves. Then read the answers together as a class and talk about *why* there is no article in some cases. Each student should be able to articulate the 'rule' by now.

'Floods' exercise

If the students are ready for a more challenging exercise, give them a copy of the worksheet on page 5. Advanced students can work on this themselves; otherwise you may want to work on it together in order to help them with new vocabulary.

In discussing the grammar, remember that the *intended meaning* of the sentence is what determines whether the noun is general or specific, so you will need to discuss the meaning of each sentence pretty carefully.

It might be even more interesting if you bring in some pictures of the floods to look at and discuss beforehand (See the *National Geographic*, January 1994).

Why it works

Students need lots and lots of examples in order to get comfortable with this grammar concept, even though this may seem repetitious to the teacher. Giving the examples in an interesting context makes the lesson twice as valuable.

Follow-up

An interesting writing assignment might be to have the students tell about something they are afraid of, and explain why. ←

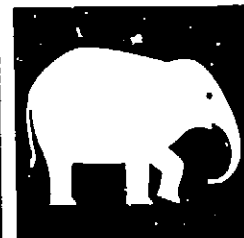

Floods in the Midwest

Floods are terrible for animals and people.
Use no article when the meaning is GENERAL
(we are talking about all floods).
GENERAL= floods

The floods were terrible this year in the Midwest.
Use an article when the meaning is SPECIFIC
(ie., we know which floods we are talking about).
SPECIFIC=the floods

Ø or the?

Write Ø in the blank if the statement is general.

Write the if the statement is specific.

1. Usually, _____ rain is not a big problem in the Midwest.
2. But this year, _____ rain didn't stop all summer.
3. _____ floods are common near the river beds.
4. This year, _____ floods went far beyond the river beds.
5. _____ houses are usually not built for floods.
6. _____ houses which got covered in water were damaged badly.
7. _____ towns along the Mississippi and Missouri rivers were hurt.
8. Some engineers say that _____ towns shouldn't be built in the floodplain.
9. But the people who live in _____ towns say they like their location.
10. Should _____ people live near big rivers?
11. Some officials say _____ people living near these rivers should move their houses.
12. Another problem is that _____ crops can be damaged by too much water.
13. This year, _____ crops in low regions were ruined.
14. _____ life can be difficult for farmers.
15. _____ life of one farmer was changed when he lost all his crops in the flooding.
16. "_____ risk is a normal part of farming," he said.
17. "But _____ risk of planting crops on floodland is too great for me."
18. _____ insurance for crops is expensive.
19. _____ insurance many farmers had was not enough to cover their losses.

Minigrants award winner:

The "Wonderful world of wood" at the West Side Learning Center

by Shirley Novak, West Side Learning Center,
Syracuse, New York.

Thanks to the *Hands-on English* Minigrant and a matching award from our local 'benefactor,' **Partners in Learning, Inc.**, the West Side Learning Center created a terrific new learning experience for students this past August. Our program offers "flexible programming"—2 hours of traditional ESL classroom instruction and 2 hours of "option" time for both the morning and afternoon sessions. Our "options" have included instruction in computer literacy, math, sewing skills and art. The woodworking project was a totally different option offered as a two-week pilot during the summer program.

Low self-esteem

West Side Learning Center serves Latino adults, primarily from Puerto Rico. Most are mandated by the Department of Social Services to be in programming which will eventually lead to employment. The majority of our students do not have high school diplomas and many have had limited positive experiences during the elementary school years. We recognize low self-esteem and a general lack of competency in basic skills as traits common to most of our students. Since our programming began over one year ago, the acquisition of English through the "hands-on" approach has proven to be very successful in building up both of these areas.

The project

We purchased three inexpensive sabre saws and a supply of replacement blades. A few tools I brought in from home (electric drill, more clamps). Large sheets of plywood were clamped to the tabletops for protection.

My woodworking skills are very basic, but I found them to be adequate in teaching those with no previous experience at all. I had previously purchased and made several simple wooden kits for home/family use. These became the core of the program. I wrote instructions for each kit, making paper templates of the curved pieces and recording the dimensions of the square and rectangular pieces.

The students could choose from the following: Shaker coat rack, towel rack with shelf, serving tray, corner shelf, child's bench and oven cooling rack.

No casualties

A vocabulary list was created and safety rules established. Over a period of 6 classroom sessions, students moved at their own pace through these steps: Choosing a project; selecting needed materials; measuring, sawing and sanding the wood; drilling holes, sanding, gluing, nailing and assembling the project; fine sanding and applying polyurethane finish to the product; showing off the finished shelf or rack. Our safety record was outstanding—not even one hammered finger!

Progress in English

All the students worked at skill-building in ESL-related areas of reading, math, listening, speaking, reasoning and following directions throughout each aspect of the project. We saw



self-esteem take an enormous boost as each student progressed from a simple plank of pine to the completion of a product which would be hung with pride, or put to use, in his or her apartment. Besides carrying home the prized possession, another mark of success was that

most of the students signed up for the next woodworking time block.

Doing it again

We plan to repeat this option block in late fall, with two five-week blocks split between math and woodworking. We now have all the equipment necessary to run the program again, and there is an adequate amount of wood and supplies remaining to get us started on another round. In the future, each student will have to pay a nominal amount for each project, allowing us to purchase more wood, nails and paint.

We found that it is possible to rent a basic sabre saw locally for \$7.00 per day. For students wishing to use their newly-developed skills at home for gift-making and/or enhancing their apartments, it is within their means to do so without buying expensive equipment. And as our skills grow, it is possible that the Center will even develop a procedure for loaning out its equipment to facilitate at-home use.

Work and pride

The philosophy at the West Side Learning Center, right from the start, has been that allowing students to feel good about themselves and developing basic skills go hand-in-hand. This "hands-on" project proved an excellent way to accomplish both. The grant provided another option of interest to our students, and another avenue through which to learn English. Don't you see our students' enthusiasm and pride shining through in the photos?



Steps/Procedures

Choose a project to make
Read the directions
Look at the pictures
Choose the correct size wood
Measure the wood
Trace the pattern pieces with a pencil
Saw the pieces
Sand the edges with sandpaper
Measure and mark where the nails go
Pound in the nails
Sand again
Cover the nail holes
Paint/apply clear finish

Materials list

sabre saw/jig saw/electric saw
electric drill
sandpaper
nails and nail set
hammer
ruler
C-clamp
wood filler and wood glue
safety goggles
screws
mitre square/T-square
wood: plywood
pine boards
dowels

More details!

If you would like further information, and more details about the patterns and instructions for each kit, Shirley will be happy to share the materials she developed for the woodworking course. Just send \$3.00 (to cover photocopying and postage) to: West Side Learning Center, Attn: Shirley Novak, 2669 E. Genesee St., Syracuse, NY 13224.

Crossword puzzle: The U.S. school system

You can look at the story on the next page to find the answers to this puzzle.

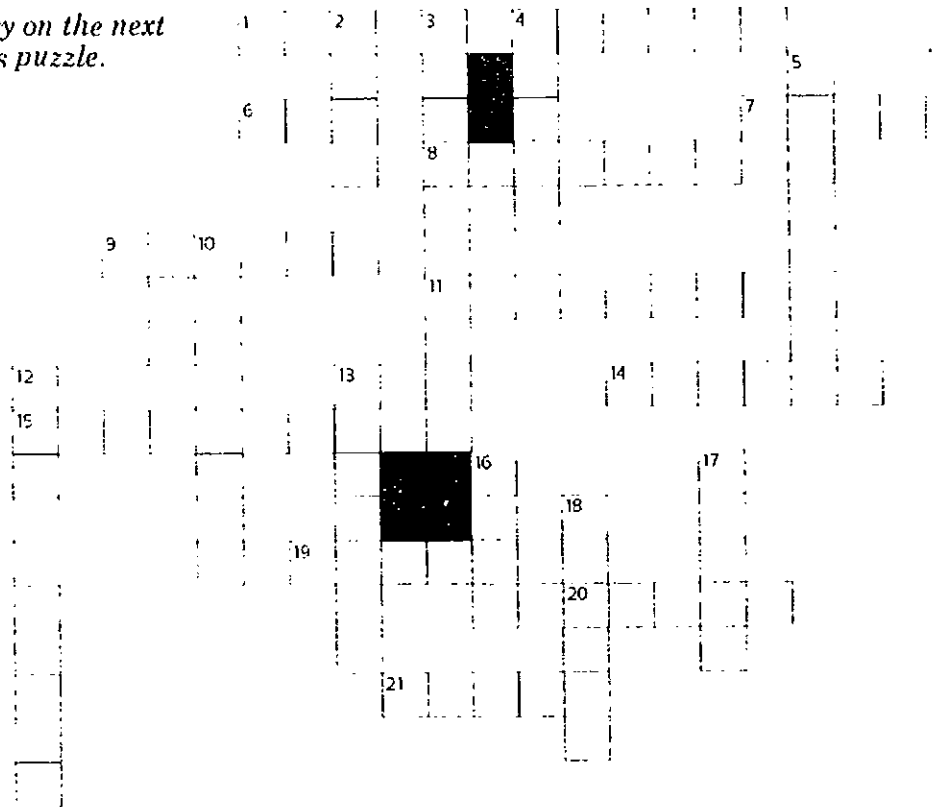

Across clues

1. The youngest children go to _____, usually for only half of each day.
6. A fifth-grade student is usually _____ years old.
7. A 10th-grade student goes to _____ school.
8. An "M.D." is a _____ doctor.
9. The _____ school system is paid for by the taxpayers.
11. My cousin is going to start medical school next year. Can you guess how old he is?
14. A synonym for "go to school" is "_____ school."
15. 'Higher education' means college or _____.
19. Students who finish high school can apply for a 2-year or a 4-year _____ if they want to study more.
20. A 10-year-old student is probably in the _____ grade.
21. Students attend high school _____ junior high school.

Down clues

2. My niece is in the fourth grade. Can you guess how old she is?
3. Young children go to _____ school.
4. My son is 13 years old and is in the 8th _____.
5. My brother is in his second year of college. Can you guess how old he is?
9. The highest degree a student can get from a university is a doctorate degree, called a _____.
10. A _____'s degree means a student finished 4 years of college (or university).
12. Twelve and thirteen-year-olds sometimes go to a middle school, or _____ school.
13. Students who finish high school get a _____.
16. Parents don't have to pay to send their children to public school, because the education is _____.
17. A first-year high school student is called a "freshman." This is the same as _____ grade.
18. Students attend high school _____ they can go to college.

About the U.S. school system

All children in the U.S. must go to school. They have the right to a free education until they finish high school, which usually means 13 years of education.

In many communities, children start kindergarten at age 5. Then they attend elementary school from 1st grade to 6th grade. Next is junior high school, which is 7th, 8th and sometimes 9th grade. After that comes high school, which is usually four years (9th grade to 12th grade). Students who finish 12th grade get a high school diploma.



Public school systems are not exactly the same in different parts of the country. This is because they are run by local governments, not by the U.S. Federal government. Most of the money for the schools comes from local taxpayers, and they help decide how to spend the money by voting in school elections.

After finishing high school, students can apply to a college or university. Although students don't have to pay for their early education in the public schools, higher education sometimes costs a lot of money.



The first four years of college or university is called the "undergraduate" education, and students who finish this usually earn a Bachelor of Arts or a Bachelor of Science degree. After that, students can apply to study in graduate school to get a PhD, or medical school to become doctor (M.D.), or law school to become a lawyer.

Discussion

1. Draw a chart of the U.S. school system. Include ages, grades, and names of schools.
2. Describe the school system in your country. How is it different from the U.S. system?
3. Some Americans feel there are problems with the U.S. system. What are these problems?
4. Some Americans feel there are strengths in the U.S. system. What are these strengths?
5. A billionaire named Annenberg recently donated a lot of money to the U.S. schools. If you could donate a lot of money to the U.S. schools, how would you like them to spend it?

Project

List the name and address of each school in your community. List also what kind of school it is, and what kind of students go there. Then, find out where each school gets its funding.

A writing activity: *Commemorative poems*

Every ESL class has its special occasions—birthdays, holidays, historic events, farewell parties...and more. These events usually involve friendship, fun, and good food—all of which are important for a great learning environment!

Nonetheless, the thoughtful, task-oriented instructor will often try to include some *language* activities in these social events to make sure they are time well spent. Here's a great writing activity that will enhance any occasion, yet assuage the conscience of the duty-minded teacher.

Teach an example

Show the students an example of a commemorative poem, in which the first letter of each line spells a word or phrase referring to the occasion. You can make up a simple one using a student's name, or show them Sal Parlato's poem about Ellis Island as an example. Explain that these poems can be funny or serious, simple or complicated.

Next, do a practice 'poem' with the whole group. Choose a word the students are very familiar with—"Saturday" would be a good one, for example. Write the word vertically on the board:

S
A
T
U
R
D
A
Y

Now ask the students to think about Saturday and what it means to them. (Give them some time to talk about this.) Have the students suggest a word or phrase about Saturday, starting with "S." If no one can think of anything, you could suggest "Sleeping late" to get them started.

Since this is a group poem, if the students come up with more than one suggestion for each letter, have the group decide which one (or ones) they like best before writing it next to the letter. When the poem is finished, have someone read it aloud to see how it sounds.

Now that the students are familiar with the concept and can see that it's not so hard to do, you are ready to work on the commemorative

poem for your special event (whatever it may be).

Offer the students the opportunity to work with a partner or small group, as this makes it easier to brainstorm for words. However, don't make this a requirement—some students might really prefer to write their own poem.

Next ask the students to brainstorm for some 'key words' to commemorate the event. They don't have to choose the same one. For example, if it's a student's birthday, the key word might be "HAPPY BIRTHDAY" or "THIRTY" or "SUSANNA," or anything else appropriate.

Give the students plenty of time to work on their poems. (If the event is to be held in the future they could even work on them at home.) You can provide some English dictionaries, and if the students are advanced you could offer them a thesaurus.

A celebration

To celebrate the great event, have each student (or group of students) read their commemorative poem aloud to the class. This is probably most effective if the students have written them out on sheets of newsprint beforehand, so the others can read along at the same time. Posting these sheets around the room will add to the festive air. A *truly* festive occasion might even include binding the students' poems into a booklet. ↩

Ellis Island

by
Sal Parlato, Jr.

Enduring
listening
learning—
immigrants
smiled,
interim
silent
languages
alphabetizing
new
dreams.

Minigrants award winner: A Video Activity

by Selda Mansour, Department of English,
Eastern Mediterranean University, North Cyprus.

Editor's note: Are you intimidated by the idea of using a video camera? If so, this project should inspire you—Selda Mansour reports that she was the first instructor in her department to try recording student presentations, and it was her first time with a video camera! Although the recordings were not perfect, she says they served their purpose better than she expected.

The students who participated in this project are my English 301 (Communications Skills) students from the Faculty of Engineering. Most of them are in their third year of studies, which means that they have only one more year to graduate. Therefore, they are very well aware of their need to improve their communication skills before they begin their professional lives.

Of the 53 students in the class, 37 are Turkish (from Turkey and Northern Cyprus), 10 are Arabs (from Palestine, Jordan, Iraq and the Sudan), and 6 are from Pakistan. Forty-six out of the 53 students are male. The class meets twice a week, for a total of 2½ hours.

One part of the course involves research. At the beginning of the semester, each student is assigned a topic related to North Cyprus, such as water pollution, marriage customs, problems of the tourism industry, etc. (the aim here is to bring the students closer with the local people and create an awareness of local issues). They gather data on the topic, and first write a preliminary report in the form of a short essay. They then turn this into an extensive report. In between, they present their findings orally in class, with the help of visual aids.

The oral presentations are by far the most stimulating part of the course. Students usually describe it as the most difficult, yet at the same time the most enjoyable activity. These 10-minute presentations are normally followed by short, lively question/discussion sessions. At the end of each presentation the class evaluates the speech according to the substance of the information, as well as the speaker's oral skills and use of visual aids.

In order to better facilitate this evaluation, this semester I recorded 5 of the presentations

on videotape. I did the recording myself as I found that only I could know what to zoom in on, and for how long.

With each presentation I focused on different aspects—the presenter's body gestures, the use of visual aids, the listener's behavior, etc. Before I showed the videotape in the class, I spent some time noting down the exact spots (on the timer) of the different parts I wanted to show. So I knew for example that with student A's presentation, the introductory part started at 02:13 and ended at 02:18, and that I should move to 03:02 for the conclusion. This proved to be an invaluable teaching aid, as it provided great flexibility in showing the presentations.

The videotape also allowed me to show the students their behavior as listeners. The short class discussions which followed the presentations became much more meaningful when they were available for evaluation. Students were able to comment on such details as a shrug or a long pause, which would not have been possible without the video. We had great fun commenting on the "Mediterranean" body gestures that were found in all the presentations, regardless of the speaker's gender, nationality or fluency.

In conclusion, although only 5 of the 53 presentations were videotaped, the activity enlivened the whole idea of oral presentations in my students' minds. As I write this report, there are 20 more presentations left until the end of this semester, and many a student comes into my office and asks, "Teacher, are you going to record my presentation, too?" Alas, I have to say no, as neither the time nor the finances would allow this. But I am very much satisfied with the results, as the oral presentations are very popular in my class now.

I would certainly like to repeat this exercise in my communication skills courses in the future. I am even planning to have my own teaching recorded, so that I can review the in-class communication process with my students and see my teaching from their points of view, which can only be partially done through written teacher-evaluation forms. ✎

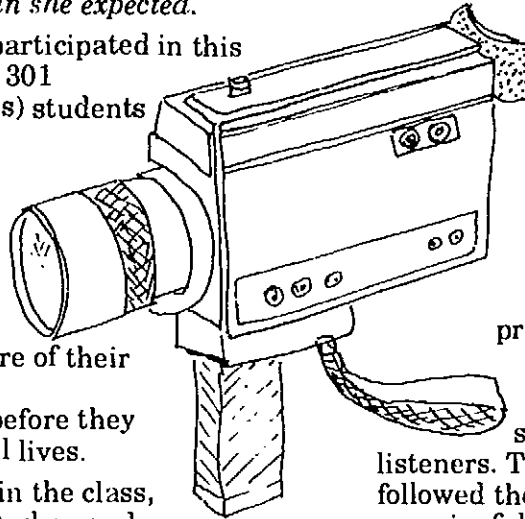

Editorial: On the fringes

Do you sometimes feel that you are on the margins of things?

Who??

We sometimes have occasion to phone a school district office to obtain the address or phone number for an Adult Education program. It's a little surprising how many times the staff person answering the phone can't answer the question—sometimes they aren't sure which program we mean, or they have to go find someone else to get the information. On one occasion we were given an address for a program that was outdated by a year and a half.

We relate this story, not just to be picky about the way school district offices are run, but rather in order to demonstrate how marginal adult programs really are in the whole scheme of things. We probably don't need to remind our readers that these programs are underfunded and undersupported, and that adult ESL programs are generally on the bottom rung of that.

Of course, ESL programs in other institutions often have the same complaint—at universities, ESL faculty are second-class citizens; in refugee programs, ESL seems like an afterthought; in literacy programs, ESL is secondary.

To put it in a nutshell. ESL has no cheerleaders! We do, however, have a lot of dedicated players plugging along successfully anyway.

Better teaching

Being "marginal" can be very discouraging and it has some very negative results. But, it does also have some plusses. Three advantages of being "outsiders" come to mind:

1. Often in adult ESL programs we are not as bound by bureaucratic requirements as teachers in other programs. We are freer to adapt our lessons to meet the real needs of our students, and this allows for more practical teaching.
2. Frequently we are unsupervised. This means we can run our classrooms as we see fit, which allows for more creative teaching.
3. Because we are "outsiders," we are in a good position to comprehend the feelings of our students, who are also outsiders. This allows for more sensitive teaching. ↵

Naturally, *Hands-on English* would prefer to see a more professional environment for adult ESL (better pay, better support, better staff development programs and more respect). Things have to change, and we hope they will eventually. But in the meantime, we can try to take advantage of the benefits of being outsiders. ↵

Hints & tips

Do you have a teaching tip that works for you? Why not share it with other readers! ESL teachers and tutors are always looking for ideas to try out with their students.

Inspirational thought

We've been trying to think of the 10 most important keys to good ESL teaching (The Ten Commandments of ESL?). Here's the first one:

LISTEN TO YOUR STUDENTS.

Every language teacher, whether new or experienced, needs to remind themselves of this from time to time. Do you wait quietly to hear what the students say? Do you ask questions you don't know the answer to? Do you give the students extra time to formulate an answer? Do you think carefully about what a student meant before responding? Do you allow yourself to be surprised by what students say?

Part of listening is waiting while students formulate an answer. Don't be afraid of silences in class, as if your students might be bored. They are more likely busily processing new information!

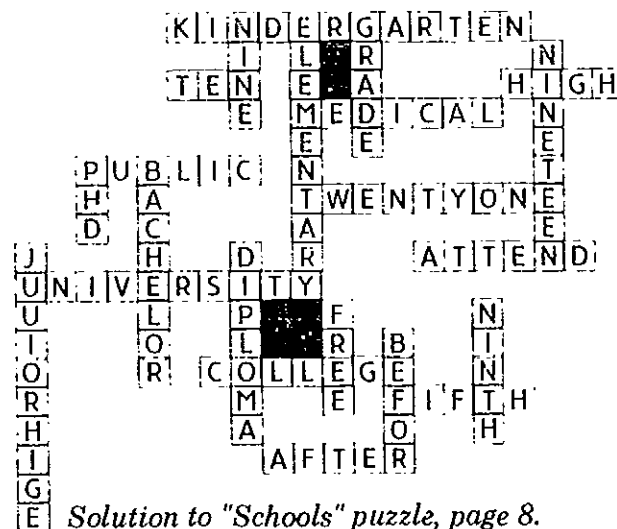

Solution to "Schools" puzzle, page 8.



Upcoming conferences

- ◆ February 2-5, 1994—**California Association for Bilingual Education (CABE)** annual conference in San Jose, California. Contact CABE, (909) 984-6201.
- ◆ February 4-6, 1994—**International Reading Association (IRA)** Conference on Adult and Adolescent Literacy in Washington, D.C. Contact: Anna Hearn (302) 731-1600, ext. 321.
- ◆ February 24-26—**Southern Conference on Language Teaching and Foreign Language Association of Georgia (SCOLT-FLAG)** joint conference in Atlanta, Georgia. Contact: Lee Bradley, (912) 333-7358.
- ◆ February 28-March 3, 1994—**National Farmworker Conference** in San Antonio, Texas. Contact: Marian Larkin, (414) 482-7200.
- ◆ March 3-5, 1994—**International Listening Association** convention in Boston, Massachusetts. Contact: Sheila Bentley, (901) 853-7690.
- ◆ March 5-8, 1994—**American Association of Applied Linguistics (AAAL)** conference in Baltimore, Maryland. Contact: AAAL, (612) 891-3500.
- ◆ March 8-12, 1994—**Teachers of English to Speakers of Other Languages (TESOL)** annual conference in Baltimore, Maryland. Contact: TESOL (703) 836-0774.
- ◆ March 13-18, 1994—**National Migrant Education** conference in Kansas City, Missouri. Contact: Cynthia Adcock, (913) 826-4718.
- ◆ March 14-18, 1994—**Computer Assisted Learning and Instructional Consortium (CALICO)** annual conference at Northern Arizona University, Flagstaff, Arizona. Contact: Eleanor Johnson, (919) 681-6455.
- ◆ April 5-7, 1994—**Association of British Columbia Teachers of English as an Additional Language (TEAL)** annual conference. Contact: TEAL '94, 177-4664 Lougheed Highway, Burnaby, B.C., Canada V5C 5T5.

Journal features adults

The most recent issue of the *TESOL Quarterly* (Autumn 1993, Vol. 27, No. 3) features more than a dozen articles on issues relating to adult literacy and ESL. These issues range from national policies to classroom practices.

Of particular interest is an 18-page article by JoAnn Crandall of the University of Maryland on professionalism in adult ESL. She describes what is a very high level of professionalism among practitioners, despite adverse working conditions. She argues in favor of credentialing and more staff development opportunities to further professionalize the field.

Members of TESOL can get a subscription to this journal with their membership, and many libraries subscribe to it also. For further information contact: TESOL, (703) 836-0774.

Worldwide refugee crisis

The United Nations warns that the number of refugees worldwide has been rising steadily. Nearly 20 million people have been forced to flee their own countries, and another 24 million are displaced within their own countries.

In 1992, for example, 10,000 new refugees a day left their countries. These horrifying numbers are four times higher than the number of refugees five years ago, and are probably an all-time high in history.

The information on refugees came from a report by Sadako Ogata, the U.N. High Commissioner on Refugees.

More and more countries are starting to react by passing measures to restrict the influx of additional refugees to their borders. Countries that were generous in the past are starting to change their policies.

The U.N. is looking at the possibility of using preventative strategies to improve human rights within countries, to try to slow the trend. This would mark a change in U.N. policy, which in the past has resisted any action that would seem to be meddling in internal politics. ➤

Announcing. . .



Minigrants 1994

Hands-on English is pleased to announce that it will award ten small grants (up to \$100 each) to teachers and tutors of ESL for an instructional project.

This marks the third year that the Minigrants will be awarded. The grants represent an effort on the part of this publication to encourage and assist teachers and tutors in a practical way. They also give *Hands-on English* the opportunity to give recognition to the good work that many instructors are doing.

Applications will be accepted through April 30, 1994. For further information and application forms, write to:

Hands-on English, Attn: Grants Manager, P.O. Box 256,
Crete, NE 68333 USA.

LifePrints

<NEW!

ESL FOR ADULTS

From New Readers Press

*If you need learner-centered core materials that focus on accomplishing life skills
...and you want lesson planning made simpler and more efficient, then LifePrints is for you!*

This exciting set of core instructional materials for adults and young adults

- powerfully combines learning to communicate in English with learning the ways and customs of North American culture
- opens the way to the English language using activities that present authentic, natural English
- provides opportunities for learners to practice language in situations typical of their everyday lives.

COMPONENTS: Student Book, Audiotape, Teacher's Edition, Teacher's Resource File

Available in 3 levels: low-beginning, high-beginning, and low-intermediate

Developed By Robert Ventre Associates with consulting editors
Allene G. Grognet of the Center for Applied Linguistic and
JoAnn (Jodi) Crandall of the University of Maryland, Baltimore

To receive your FREE *LifePrints* Sampler
Call 800-448-8878 (Dept. 108) TODAY!

Or write to New Readers Press, Box 131, Dept. 108
Syracuse, New York 13210-0131 • 315-422-9121

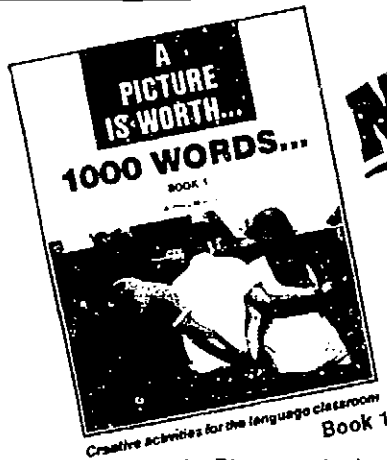

NEW!
includes

by
Anthony Mollica

Teacher's Guide to
A picture is worth... 1000 words...

by
**Anthony Mollica
Julie Ashcroft
Anne-Marie Finger**

\$24.95 each Add \$4.00 for Shipping



Creative activities for the language classroom
Book 1

Creative activities for the language classroom
Book 2

- ✓ 60 Photographs by North American photographers
- ✓ Each photograph may be photocopied for classroom use

- ✓ Excellent visual stimuli for comprehension and discussion
- ✓ Suitable for different grade level and multi-level classes

Detachable Line-Masters for Reproduction

The *Guide* provides a series of questions to stimulate the students'

- ✓ visual comprehension
- ✓ personal interpretation
- ✓ creativity

at three linguistic levels

- ✓ beginning
- ✓ intermediate
- ✓ advanced

A *Teacher's Guide* is available in

- English
- French
- German
- Italian
- Spanish

(Please specify language.)

éditions SOLEIL publishing inc.

P.O. Box 890 • Lewiston, New York 14092-0890 • Tel./Fax (416) 788-2674

EDUCATIONAL SHOWCASE

Your ESL Connection

Providing ESL/EFL Programs for All Ages

The Largest Collection of ESL Materials
on Display in the Midwest

- * Place orders by mail or fax: (313) 680-1052
- * UPS delivery in 5 to 10 days of in-stock items
- * We meet publisher's prices AND beat the service
- * To order or to receive our comprehensive ESL catalog write to:



EDUCATIONAL
SHOWCASE
1334 Wheaton Street
Troy, MI 48083
(313) 680-0860

Classified ads

To place a classified ad, send your notice of 30 words or less with US \$10 (subscribers get a discount of 50%) to: Hands-on English, P.O. Box 256, Crete, NE 68333 USA. Phone/fax: (402) 826-5426. Toll free call-in: 1-800-ESL-HAND.

Publications:

Now available—THE ESL LOCATOR:
Sal Parlato's updated guide to 1,200 national ESL organizations. Prepaid \$11.50 (includes S&H) from TESOL, Booklink, or from: Dolores Parlato, 248 Seville Dr., Rochester, NY 14617.

Back issues of *Hands-on English* are now available at US \$4 per copy (this includes shipping costs). Let us know which issues you're missing! See our address above.

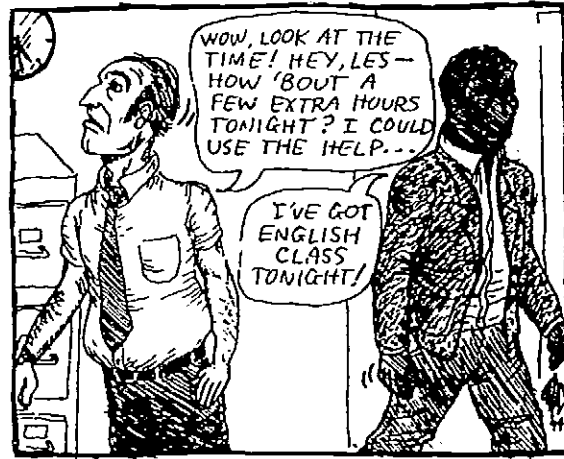
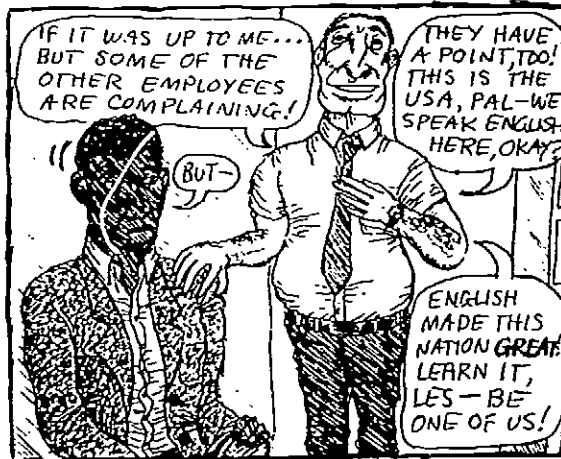

Hands-on
English

A periodical for teachers and tutors of adult ESL
P.O. Box 256
Crete, NE 68333
USA

BULK RATE
U.S. POSTAGE
PAID
CRETE, NE
PERMIT NO.256

ADDRESS CORRECTION REQUESTED

January/February issue



Hands-on English

A periodical for teachers and tutors of adult English as a second language

Editorial:

Some pats on the back

Look at us!

As we look back proudly at the first three years of our publication, we realize how much has happened in a short time. More than a thousand subscribers receive *Hands-on English*—in all 50 U.S. states, six Canadian provinces and several other countries! And many of you have shared articles, ideas, stories and tips, giving us a wealth of good, practical material to pass along to the other readers.

We're pleased with our useful content, which is unlike any other ESL publication you can get. We've recently expanded to a longer format, without raising the cost of a subscription, so we can bring you more useful information. And we're attracting more attention from publishers and ESL professionals.

Our kind of people

We think the one thing that makes *Hands-on English* really unique, though, is our subscribers! You are the practitioners—deeply involved in trying to make things work for your students. Dedicated to helping others improve their lives. Eager to try something new in your teaching, willing to reflect on your work.

You are also sometimes exhausted, overworked and overwhelmed with responsibilities—that's why we want to do anything *we* can to make your job easier. So, keep up the good work, don't wear out, and let us know if there's anything we can do for you!

In this issue

We received two thoughtful articles for this issue that remind us again that ESL is so much more than just language teaching. We think you will be moved by "In memory of a student" on page 3, and perhaps identify with

the teacher who wrote "Coining, Aspirin and ESL." on page 9.

Our ready-to use lessons for this issue include a multi-level puzzle about common verbs, called "Everyday actions," (p.4) and a great vocabulary/cultural activity called "Shop until you drop!" (p.6). And for some insight into using food for more than just eating, see "Cooking up Cultures" on page 10.

We're including an index of all six issues in Volume III, so you can more easily find past items when you need to. (We also have a special offer if you'd like an index of ALL our back issues—see page 15.) And finally, Lester's adventures in the cartoon "Nightschool" are for both you and your students to enjoy. ➤

Contents:

From the field:

- In memory of a student.....3
- Coining, Aspirin and ESL.....9

Crossword puzzle:

- Everyday actions4

Cultural activity:

- Shop until you drop!.....6

Minigrants award winner:

- "Cooking up Cultures"10

Tutors, too:

- The "Language Experience" story.....11

News & notes.....12

Index to Vol. III.....13

"Nightschool" -an ESL cartoon.....16

Hands-on English

Volume III, Number 6
March/April 1994

Hands-on English (ISSN 1056-2680) is published six times a year (Jan./Feb., March/April, May/June, July/Aug., Sept./Oct., Nov./Dec) by Hands-on English, P.O. Box 256, Crete, Nebraska 68333 USA. Printed by Precision Printing, Crete, Nebraska. Copyright © 1994 Hands-on English

Subscription rates: \$16 for regular subscribers, \$10 (discounted rate) for volunteers or teacher's aides, \$22 (multi-user rate) for libraries or institutions. Postage & handling: Canada and Mexico add \$4; outside N. America add \$10. Single copies of back issues are \$4 each.

Permission to photocopy: This periodical is copyrighted. However, we invite teachers and tutors with a paid subscription (or whose institution has a paid subscription) to make as many copies as they need for their own classroom use. (Please don't make copies for colleagues! We survive on subscriptions.)

Editor: Anna Silliman
(M.A. Teachers College, Columbia Univ.)
Consulting Editor: Karen Campbell
Cartoonist: Michael Capurso
Grants Manager: Peter Dowben

Address correspondence to the editor at:
Hands-on English
P.O. Box 256
Crete, NE 68333 USA
Or:
Fax/phone: (402) 826-5426.
Toll free call-in: 1-800-ESL-HAND
E-mail: 73651.1122 @ compuserve.com

Subscribe today!

Send this form with your check or money order (U.S. funds only) to the above address.

Please send me a subscription to *Hands-on English* for one year (6 issues). I enclose:

- \$16 Regular teacher rate
Permission to photocopy for teacher's own class(es)
- \$10 Discounted rate for volunteers or aides
Permission to photocopy for your own student(s)
- \$22 Multi-user rate for organizations
Permission to copy for multiple teachers/tutors
- _____ Postage/handling: Canada/Mexico add \$4.
Countries outside N. America add \$10.

Name: _____

Address: _____

Institution: _____

Position: _____

Check one: New subscription Renewal



Your editor... keeping warm under a pile of ESL materials, and looking forward to hearing from you!

From the field:

In memory of a student

How do you think your school would respond in a crisis? We heard how one school acted as a community in the face of tragedy:

Dear Ms. Silliman,

In the September-October issue of your journal, there appeared a request for a sharing of experiences dealing with crime-related issues with ESL students. One of the specific recent incidents mentioned was the killing of a Japanese student. We assume that you were referring Masakazu Kuriyama, who was a student at our school.

Masa's tragic death resulted in a tremendous wave of emotions from students and staff. He was an exceptional individual whose painful loss was completely incomprehensible, and the primary focus of our entire program at the beginning of the school year was on healing and understanding. The process still continues and much is yet unresolved. However, we would like to share a summary of our activities to date.

Effective ESL classes are known for establishing open environments that are conducive to increased intercultural awareness and tolerance. Our teaching staff provided a forum for all who knew Masa to talk about how we deal with the loss of a friend from a personal, social and cross-cultural perspective.

We explored the theme of violence in American society, and we discussed self-protection and prevention strategies. It was not a pleasant experience, but we feel that our students appreciated the fact that we recognized what needed to be done and addressed the issues in a straightforward manner.

Masa had a joyously open spirit. That spirit is what we try to carry with us as we remember him. In his memory, students and staff have learned important lessons about ourselves and about each other.

Sincerely,

Jacques LaCour, Coordinator
ABE/ESL/Citizenship
Loma Vista Adult Center
Concord, CA 94518

Planned activities

We here at Loma Vista Adult School in Concord, California have had the experience of designing a method of coping with events following the murder of one of our students. Masakazu Kuriyama, a young Japanese student, was shot and killed near the local train station not far from school. The approach of the staff in dealing with the tragedy and the full range of attendant emotions expressed by staff and students alike was three-fold, involving activities (1) for teachers by teachers and staff, (2) for students by staff, and (3) for students by students.

In our initial back to school staff meeting, the ESL coordinator provided a "healing" opportunity for teachers who had known Masakazu by inviting teachers to express their feelings in words of remembrance of the student who had been a popular, fun-loving young man. Also discussed were precautions we all should be taking as we deal with an increasingly violent society, as well as what kinds of information would be advisable to impart to our students.

Following this, one member of the staff, a trained grief counselor, wrote a brief summary dealing with grief issues which included detailed information on how various ethnic groups approach the subject of death. This information was disseminated to all instructors.

Among activities planned for students by the staff were the organization of small in-class group discussions dealing with American patterns of grief and funeral customs, followed by student sharing of the ways in which grief and death are treated in their respective countries. For a two-week period teachers and staff alike wore small black ribbons to show solidarity with grieving students. In some cases students' queries about the ribbons prompted a discussion of the tragedy.

In addition, a grief counseling session was planned for students. A letter of invitation to the session was sent to all who had been classmates and/or special friends of Masa's. Staffing this were trained grief counselors, one of whom was a representative from the local crisis and suicide prevention agency, and a Japanese man who was a former counselor for the school district. In order to increase awareness of the dangers on the streets of the city, the sheriff's department was contacted about an informational meeting dealing with this subject.

Equally important, if not the most important events, were the activities planned largely by Japanese students for the entire student body. Included in the memorial service at the school were brief talks by staff members selected by the students themselves and a tree planting ceremony accompanied by the lighting of incense. Many students, teachers, and office personnel were present at this service.

All the events seemed to be instrumental in bringing about the beginning of a much-needed healing in the wake of this horribly senseless tragedy.

Sandra Lehmkuhl, Instructor
Loma Vista Adult School
Concord, California

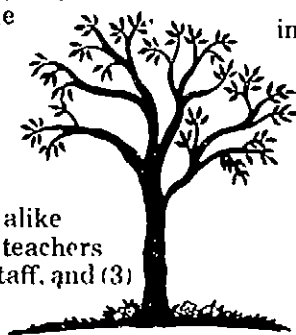

Multi-level crossword puzzle: Everyday actions

Level A

Across clues

2. Will you please _____ the baby for a minute? I have to cook the soup.
3. I like to _____ with my friends on the telephone.
4. "Would you like something to _____?" "No, thanks, I'm not thirsty."
6. "_____ this photograph of my mother." "Oh, she looks very nice."
7. Do you know how to _____ a car?
10. I usually _____ a newspaper from my country every week.
11. I like to _____ to music on the radio.
13. We have to leave now. Give the baby a _____ and say goodbye!
14. Let's _____ T.V. tonight.
17. "Where are the children?" "They went outside to _____."
18. Last night I didn't _____ very well. Now I'm very tired.

Down clues

1. It's time to _____ dinner. We will eat in an hour.
3. "Do you want to buy this?" "I don't know. I'll have to _____ about it."
5. Please _____ down. It's time for class.
6. "Why are you going to school?" "Because I want to _____ English."
8. I don't have to ride the bus to school. We live near here, so I can _____.
9. "Would you like to _____ my home? You can come at 3:00 o'clock."
12. Would you like to _____ dinner with us?
14. I'm going to _____ a letter to my uncle.
15. Here's my telephone number. You can _____ me tomorrow.
16. These flowers are beautiful, and they _____ very nice.
19. I have to _____ the rent on Monday.

Level B

Across clues

2. You do this with your arms.
3. You do this with your mouth.
4. You do this with a cup of coffee.
6. You do this with a photograph (2 words).
7. You do this with your car.
10. You do this with a newspaper.
11. You do this with your ears.
13. You do this with someone you love.
14. You do this with your eyes.
17. You do this with children.
18. You do this with your eyes closed.

Down clues

1. You do this in the kitchen.
3. You do this with your brain.
5. You do this with a chair.
6. You do this in school.
8. You do this with your feet.
9. You do this with your friends.
12. You do this with food.
14. You do this with a pencil.
15. You do this with the telephone.
16. You do this with your nose.
19. You do this with money.

Level C-Student 1

Write a clue for each of the ACROSS words in this puzzle. Then cut off the clues and give them to your partner.

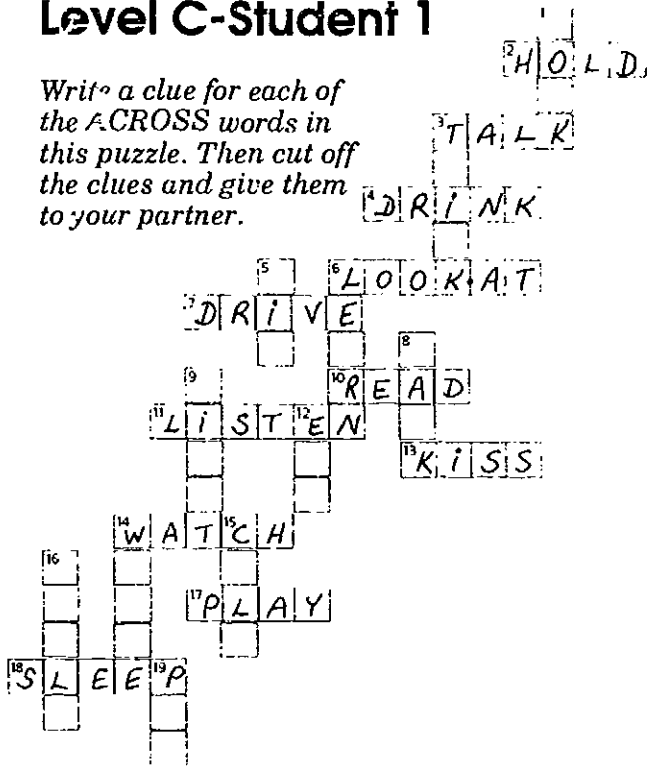

Across clues

- 2.
- 3.
- 4.
- 6.
- 7.
- 10.
- 11.
- 13.
- 14.
- 17.
- 18.

Level C-Student 2

Write a clue for each of the DOWN words in this puzzle. Then cut off the clues and give them to your partner.

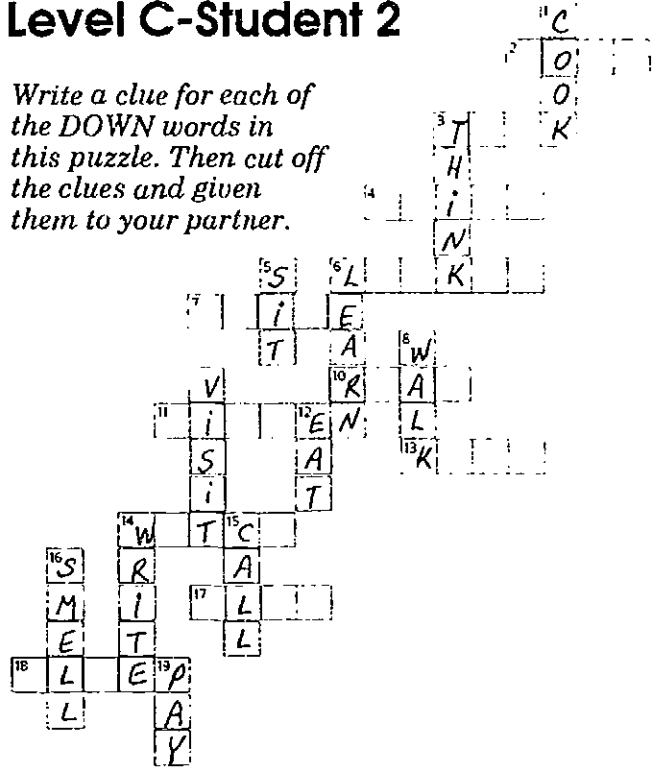

Down clues

- 1.
- 3.
- 5.
- 6.
- 8.
- 9.
- 12.
- 14.
- 15.
- 16.
- 19.

To the instructor: Pair up level C students and give each student one half of this page. When they finish writing clues, they exchange them to solve the missing half of the puzzle.

If your students enjoy writing puzzle clues, you can find more examples like this in *Talk-a-tivities* by Richard Yorkey (Addison-Wesley Co. 1985) ISBN 0-201-09911-X.

Cultural activity: Shop until you drop!

by Joy Egbert, ESL teacher at Palomar College, San Marcos, California.

Stores are organized differently in different countries. In a new country, how do you know where to find things? This activity will give your students some practical information about shopping here.

"Shop until you drop" is designed for low-level adult students who need to learn basic skills—such as using a dictionary and scanning for information—but who also need specific knowledge and vocabulary for dealing with the new culture. You can use the activity as part of a unit on shopping, the U.S. economy, newspapers, American culture, or cities. It also works well as a small group activity.

Preparation

Before doing the exercises, learners should be familiar with alphabetical order and have had a general orientation to the dictionary and the phone book. You will need to have phone books and newspapers (any date) on hand for the activity, so you may want to assign learners to bring in a phone book (with yellow pages) for homework.

Before copying the worksheet, fill in one example each in Exercise II and III by writing the name of a store in your area that the students might be familiar with.

Procedure

Exercise I. Where can you buy it? This exercise can be done in small groups with dictionaries, or students can take the worksheet with them and ask local people for information. (If learners are going to interview native speakers to find the answers, prepare them first with some pronunciation and conversation review. You may also want to suggest ways of approaching people with questions.)

Exercise II. Is there a department store here? Review the telephone book briefly first. Work with learners to complete an example before they get started on their own.

Exercise III. What kind of store is it? Give learners time to put their dictionaries away and shift to the newspaper. Do an example together, to make sure they understand how to do the exercise. (You may want to use newspaper examples to discuss advertising techniques as well.)

Variations and follow-up

Grammar focus—You can ask the learners to respond to Exercise II in specific ways, eg. in complete sentences, using present tense, underlining capital letters. In Exercise III they can look for certain structures (verbs, for example) in the newspaper ads.

Writing—Learners can write a paragraph about the activity.

Listening/speaking—Learners can place a telephone call to one of the stores on their list and ask about specific items (price, availability, color, and so on).

Interview—They can conduct a survey to discover each others' preferences for places to shop.

Field trip—They can go on a "treasure hunt" at a shopping mall to find the answers to questions about the stores there.

Discussion—1) Have learners describe shopping in their home countries.

2) Not just stores! Learners are probably already familiar with alternatives to shopping in stores. Ask them to pool information about where to get household items, clothes, etc. (This might include: garage sales, rummage sales, thrift shops, classified ads, bulletin boards, agencies and friends.)

Why it works

Students are eager to learn about finding their way around, and this exercise gives them a chance to get a practical understanding of their new culture. Best of all, they get this information by researching it themselves.

As a learning tool, putting things in *categories* is a very effective way of learning new words and understanding new concepts. ➔



Shop until you drop!

Exercise I. Where can you buy it?

There are many different kinds of stores. Each store sells different things. Look at the list below, and match the kind of store with the things it sells. If you are not sure of an answer, look in your dictionary or ask someone who lives here.

- | | |
|-------------------------------|---|
| _____ 1. Leather goods store | A. Cards and paper products |
| <u>D</u> _____ 2. Linen store | B. Party food, and special food to take out or have delivered |
| _____ 3. Pharmacy | C. Alcoholic beverages |
| _____ 4. Stationery store | D . Sheets, pillow cases, towels |
| _____ 5. Gourmet catering | E. A corsage or roses |
| _____ 6. Liquor store | F. Wood and other building materials |
| _____ 7. Florist | G. Frames for pictures |
| _____ 8. Lumberyard | H. Handbags, purses, belts |
| _____ 9. Hardware store | I. Materials for sewing, buttons, patterns |
| _____ 10. Fabric store | J. Hammers, nails, supplies to fix things |
| _____ 11. Software store | K. Computer programs |
| _____ 12. Frame shop | L. Medicine |
| _____ 13. Consignment shop | M. Second-hand (not new) clothes |
| _____ 14. Pawn shop | N. Clothes, housewares, appliances at regular prices |
| _____ 15. Department store | O. Cash for items you bring, for example TV, jewelry, etc. |
| _____ 16. Discount store | P. Clothes, housewares, appliances at low prices |

Shop until you drop, (continued)

Exercise II. *Is there a department store here?*

Here are 16 kinds of stores. For each kind of store, can you give the name of a store in your area? (If you don't know, look in the Yellow Pages of the telephone book.)

Write at least one store name for each kind of store.

Leather goods—

Linen store—

Pharmacy—

Stationery store—

Gourmet catering—

Liquor store—

Florist shop—

Lumberyard—

Hardware store—

Fabric store—

Software store—

Frame shop—

Consignment shop—

Pawn shop—

Department store—

Discount store—

Exercise III. *What kind of store is it?*

Look in the newspaper and find store advertisements. For each ad, write what kind of store it is, the name of the store, and what items they are advertising for sale.

	Name of store	Kind of store	Items for sale
1.			
2.			
3.			
4.			
5.		230	

From the field:

Coining, Aspirin and ESL

by Lucie Germer, who has taught adult ESL in the past, and is currently teaching elementary ESL in Marlborough, New Hampshire.

Lucie raises an issue that has bothered many of us who stand between two cultures—about what our responsibility should be.

Where do we draw the line? As ESL teachers we often find ourselves acting as the experts in the middle—explaining our culture to our students, and theirs to Americans. That's why I found myself at the doctor's with my third-grade Cambodian student and his mother, Chantha, who had been my student in the adult ESL class. The doctor drew me aside and said, "I think we're looking at a real case of abuse here. Look at that child."

I knew the boy had had the flu for over a week, so I wasn't really surprised to see rusty marks over his forehead, neck and chest. I knew that in Southeast Asia, a coin is rubbed on the skin until there is a weal, to help cure a variety of ailments. A Vietnamese friend had coined me when I had a headache, which had indeed gone away (though I'd also taken some aspirin), so I knew that the practice was not painful or permanent.

As I looked at the concerned doctor, though, I realized that again I was going beyond the standard role of the ESL teacher. What was I supposed to do? I was no real expert on Southeast Asian health practices—and I was certainly not an expert on American medical or legal problems. But Chantha and the doctor both expected me to do something.

I did my best. I explained coining, as far as I understood it, to the doctor, emphasizing that this was not abuse but rather a traditional health practice. Luckily I was convincing, because as we went home I had to tell Chantha how close she had come to being accused of child abuse. She was horrified, but also worried: what would she do now for aches, pains, and fevers?

I told her that Americans don't understand coining; that she should learn about American cures for colds and flu, even though they don't always work very well; and that she should be careful never to coin where Americans would be likely to see the marks, because Americans get upset.

Then I went home and worried. Suppose some Southeast Asian health practices that I didn't know about really were dangerous, and by accepting coining I was accepting those. Suppose I was sending the message to Chantha that you could do anything you want to a child as long as the marks don't show. Suppose...

I finally decided that as an ESL teacher my responsibility is to explain and clarify, not to make other people's decisions for them. Our students have to know when they are doing something that will bring them into conflict with American laws or taboos, but what they do privately is their own business.

I called the teacher of the adult ESL class and suggested a lesson on colds and flu. She said, "I was just thinking of that—I have a Brazilian student who makes a kind of garlic tea for colds. Is it my job to tell him what that smells like to Americans?"

I think it is. But because we are here to inform, even when we keep getting into areas beyond our expertise, I've worked out some rules of thumb to use:

1. If I don't understand their health practice, I'm going to ask and, when possible, read up on it.
2. If their practice seems dangerous or unhealthy to me, I'm going to check with an expert before I jump in and start giving advice. (BUT, if the danger seems immediate, I'll report it, running the risk of making a fool of myself or losing the trust of the family, if necessary.)
3. I'll present the contrast between American and home health practices as a matter of information. Adults should know the options and make their own choices—and who knows? Maybe an American remedy will work where a traditional one never has, or perhaps a traditional one is quicker and has fewer side effects.

I could learn something, too. I do know that no one has all the answers.

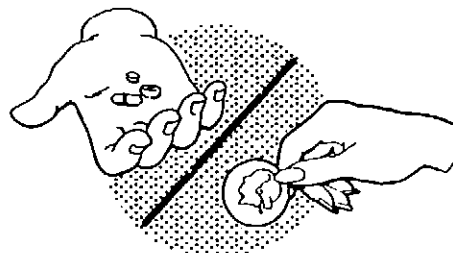

Minigrants award winner: Cooking up Cultures

Many ESL classes have shared food, and even cooked together. Some have exchanged recipes, or collected them in a book. But this project takes the sharing of food and recipes one step further—using it as an opportunity to share stories about each other's cultures.

Diane E. Scott, ESL teacher at the Metro-Nashville Adult Education program in Nashville, Tennessee, reports:

"My multi-level class participated in a year-long project to study cultural differences, customs and foods eaten by different groups. The students in this project were from Czechoslovakia, Haiti, Iran, Laos, Mexico, Puerto Rico and Thailand.

"Through a series of activities the class now has a better understanding of the basic recipes, cooking procedures and varieties of foods from each others' cultures. We've had group dinners, picnics, and field trips to local bakeries to supplement our class activities.

"In addition the students learned some nutrition concepts, studied count and non-count nouns, discussed measurements, and increased their food vocabulary.

"Each student wrote a recipe, including cultural information, that will be included in the *Adult Education ESL International Cook Book*."

The activities Dianne's students participated in included:

- ❖ Discussing their cooking experiences in a small group.
- ❖ Writing down a recipe, then explaining to the small group how they learned about this food, when it is usually prepared, and why.
- ❖ Meeting at the teacher's home to prepare some of the recipes together.
- ❖ Using the students' recipes to discover count and non-count nouns.
- ❖ Looking at examples of cookbooks (including Betty Crocker's *New International Cook Book* and Jeff Smith's *The Frugal Gourmet on our Immigrant Ancestors*).
- ❖ Comparing eating customs in different cultures.
- ❖ Planning the publication of their own *Cooking up Cultures* cook book. ↵

Here's a sample page from their cookbook:

Good Luck Recipes	
Japan	Ozoni Soup
Mochi, a sweet rice cake, is served in <i>ozoni</i> , the January 1st soup of good health and fortune. A pyramid of fresh mochi-cakes symbolizes past generations supporting present and future generations.	4 oz. boned & skinned chicken breast 1 1/2 teasp. light soy sauce 1 teasp. sake salt 4 medium prawns a 2-inch chunk of daikon radish, peeled 1 medium carrot, peeled 4 oz. spinach, washed and dried 4 rice cakes 4 1/2 cups Dashi 12 slivers lemon zest Cook as a soup, and drain. Rice cakes float in the soup.



Tutors, too:

The "Language experience" story

Recently we saw this request for help from a teacher on the TESL-L computer network:

"I'm going to start tutoring someone one-on-one this weekend and I'm a bit at a loss about what to do because all of my training and experience is in a classroom with more than one person. This woman's level is very low. She knows only the present tense and has a limited vocabulary. She lives with her family, who all speak her native language (Turkish). She doesn't get out much and, as far as I can tell, wants to learn English so she can make friends and answer the telephone.

"I'd like some ideas on activities I can do with her that would be one on one. Specifically, I would like to spend some time of every hour 'playing games,' because she is really afraid of speaking English. Do you know of some games or other 'fun' activities? She also wants homework. . . I'm looking for some creative ideas."

Karyn Campbell
Kettering, Ohio

Dear Karyn,

In response to your question, you might want to try a 'language experience' story with your student. This is a technique that a lot of literacy tutors use (I first learned about it from Literacy Volunteers of America), and is also used in elementary schools to teach beginning reading. Unfortunately, many of us classroom ESL teachers don't know about this useful technique!

What to do

Have your student tell you about something—what she did yesterday, how she came to America, or something else of importance to her. An excellent topic is to have her explain something she knows how to do well. You could start this by saying, "I want you to tell me a story."

Do this informally, just listening to the story and chatting about it.

Next, ask her to tell you the story again. This time, get out a piece of paper and write down what she says. You can start this by saying, "Tell me your story again, so that I can write it down." Don't make corrections as you write, unless the student asks or wants to make changes herself.

Now, you read the story carefully aloud, then have her read it aloud to you. If she wants to add something, you can do so. At this point, you have a written record of something your student wanted to say.

She can study this story for homework, if she wants to. You can create all kinds of language exercises & games from her own words. For example, at your next session you could give her a dictation from her own story, or you could do vocabulary matching games with 3x5 cards, depending on what kind of practice she needs.

If she likes the experience story technique, you could do it at regular intervals, saving her stories in a notebook as a record of her progress. This also provides an easy way to review. This activity works well because all of the material is generated by the student, so you are really working on what she is interested in.

A Ukrainian story

I have used this technique with ESL students who lacked confidence, and found it a tremendous boost for them. One Ukrainian man I worked with was very sad and depressed about his life and his "poor" English. I discovered, though, that he and his son had completely remodeled an old house in which they were now living. So I asked him to describe in detail how they did it, and wrote it all down.

He nearly cried with pleasure and pride when I gave him his finished story. He had no idea he knew so much English! He brought it to class the next time and made sure all the other students read it. He gained respect from all of us for his remodelling achievements.

I'm sure our readers will have further suggestions for you, Karyn. If so, we'll pass them along.

Best wishes,
Anna Silliman

p.s. If you are working with a pre-literate student, you might want more details about how to use this technique to teach reading. See LVA's handbook called **Tutor**, by Ruth Colvin and Jane Root. It costs \$11 and is available from LVA at 315-445-8000. ↵



Upcoming conferences

- ◆ April 5-7, 1994—**Association of British Columbia Teachers of English as an Additional Language (TEAL)** 27th annual conference. Contact: TEAL '94, 177-4664 Lougheed Highway, Burnaby, B.C., Canada V5C 5T5.
- ◆ April 6-9, 1994—**American Association of Community Colleges (AACC)** annual conference in Washington, DC. Contact: Mary Ann Settlemire, 202-728-0200, ext. 229.
- ◆ April 8-9, 1994—**Illinois TESOL/Bilingual Ed** annual state convention, Radisson Hotel, Lincolnwood, Illinois. Contact: Suzanne Leibman, College of Lake County, 19351 W. Washington St., Grayslake, Illinois 60030. (708) 223-6601, ext. 2951.
- ◆ April 8-9, 1994—**Massachusetts TESOL** spring conference, Roxbury Community College, 1234 Columbus Ave, Boston, Massachusetts. Contact: Betty Stone, (617) 625-6600, ext. 6933.
- ◆ April 9, 1994—**Connecticut TESOL** in Meriden, Connecticut. Contact: Francena Dwyer, 158 Somerset Dr, Berlin, Connecticut 06037. (203) 225-4397.
- ◆ April 14-17, 1994—**California Association of TESOL (CATESOL)** annual state conference in San Diego, California. Contact: Peter Thomas, English Language Program, UCSD, La Jolla, CA 92093. (619) 534-0425.
- ◆ April 15-16, 1994—**Wisconsin TESOL** annual spring conference at the University of Wisc.-Madison, in Madison, Wisconsin. Contact: Sarah Jensma Stewart, 2914 Stevens St., Madison, WI 53705. (608) 829-4127.
- ◆ April 28-30, 1994—**Carolina TESOL and North Carolina Association of International Educators** joint conference in Raleigh, North Carolina. Contact: Nancy Blount, Wake Technical Community College, 9101 Fayetteville Rd, Raleigh, NC 27603. (919) 772-0551, ext. 195.
- ◆ May 5-7, 1994—**Gulf TESOL of Florida, Inc.** annual conference in Fort Lauderdale, Florida. Contact: Allene Grognet, 7069 B South Tamiami Trail, Sarasota, FL 34231.
- ◆ May 7, 1994—**Michigan TESOL** at Ferris State University in Big Rapids, Michigan. Contact: J. Penny Wheeler, IEP, FSU, Big Rapids, MI 49307. (616) 592-3916.

◆ May 8-12, 1994—**International Reading Association (IRA)** 39th annual convention in Toronto, Ontario, Canada. Contact: IRA Conferences Div., P.O. Box 8139, Newark, Delaware, 19714-8139. (302) 731-1600.

◆ May 19-20, 1994—**New Jersey TESOL-New Jersey Bilingual Educators** at the Hyatt Hotel, New Brunswick, New Jersey. Contact: Lynda Mejias (908) 826-3360, ext. 247.

◆ May 19-22, 1994—9th annual conference of the **National Multicultural Institute** in Washington, DC. Write to: 3000 Connecticut Ave, NW, Ste 438, Washington, DC 20008-2556. Or phone (202) 483-0700.

◆ June 2-5, 1994—**Laubach Literacy Action Biennial Conference** on adult literacy in Little Rock Arkansas. Contact: Janet Hiemstra, LLA, (315) 422-9121.

◆ June 20-August 5, 1994—**TESOL Institute** at Iowa State University. Thirty 3-credit graduate courses available. Contact: Dept. of English, 316 Ross Hall, ISU, Ames, Iowa 50011. (515) 294-7819.

Just like it sounds

Edith Kennedy in Key West, Florida told us about a Spanish-speaking student who was teaching herself English by listening carefully to the television, and then bringing questions about what she heard to her tutor.

One phrase she heard a lot so she jotted it down and showed it to her tutor: *Jabanaisde*. Do you know what it means?

Video request

Does anyone have titles of short video tapes they have used successfully with ESL students? Jane Bailey of Mesquite, Texas is looking for tapes to use with closed-caption devices so that students can both read and listen.

If we get more information, we'll print an article about this exciting new technology.

Beam us up

Speaking of technology, you can now reach the editor of *Hands-on English* by e-mail. If you are on CompuServe, the address is 73651,1122.

From the Internet, the address is: 73651.1122 @ compuserve.com

So, drop us a line!



Index to articles in Volume III

Here's our annual round-up of Hands-on English articles! (If you like indexes, see p.15 for a special offer.)

Advertisers

éditions SOLEIL publishing. III-1 to 6.
Educational Showcase. III-1 to 6.
Intercultural Press. III-1, 2.
New Readers Press. III-3, 5, 6.
Orbis Publications. III-6.
Pro Lingua Associates. III-1, 2, 6.
Vocational English Lang. Svc. III-6.

Authors

Brody, Jane. Minigrants award winner: "Brighter Horizons Student Incentive Project." III-2, p.8.
Curlee, Karen. Tips for tutors about writing. III-1, p. 12.
Edwards, Patricia. Minigrants award winner: "Books-in Camp." A family literacy project for migrants. III-1, p.6.
Egoert, Joy. "Shop until you drop!" a cultural activity. III-6, p.6.
Germer, Lucie. "Coining, Aspirin and ESL" Cross-cultural health issues. III-6, p. 9.
Grane, Joyce. Minigrants award winner: "The YWCA Pizza Restaurant" activity. III-4, p.4.
Lehmkuhl, Sandra. "In memory of a student." School activities after a tragedy. III-6, p. 3.
Lockwood, Sally. "News photo captions," a speaking/reading activity. III-3, p.4.
Lucas, Mary Jane. "Multi-level word matching: Occupations." III-2, p. 2.
Manour, Seida. Minigrants award winner: "A Video Activity." III-5, p.11.
Novak, Shirley. Minigrants award winner: "The wonderful world of wood." III-5, p.6.
Pariato, Sal "Ellis Island," a poem. III-5, p.10.
"Limerick Latino," a poem. III-2, p. 5.
"Teach me," a poem. III-3, p. 10.
Scott, Dianne E. Minigrants award winner: "Cooking up Cultures." III-6, p.10.

See also: **Hints & tips**

Cultural activities & info

Coining, Aspirin and ESL. Cross-cultural ESL issues. III-6, p.9.
Cooking up Cultures. Learning about other cultures through food. III-6, p.10.
Commemorative poems; to celebrate class occasions & holidays. III-5, p.10.
Shop until you drop! III-6, p. 6.

Editorials

Bad sounds? Pronunciation problems are not always solved by practice. III-4, p.12
Moving blues; the difficulties of readjustment. III-2, p.4.
Myths about learning English; it's not as easy as people think. III-3, p.6.
On the fringes; adult education remains outside the mainstream. III-5, p.12.

Grammar grab-bag

Conjunctions: because, in order to, so that. An interview activity. III-3, p.1 & 9.

Present perfect with *been*—"The places I've been," a conversation activity. III-4, p.1 & 3.

Tense review—"I'm going away next week," conversation activity. III-1, p.4.

Group activities

Discussing the U.S. school system; a reading. III-5, p.1 & 9.
News photo captions; a speaking/reading activity. III-3, p.4.
Restaurant simulation activity: The YWCA Pizza Restaurant." III-4, p.4.
See also: **Cultural activities & Reading.**

Hints & tips

Blank flashcard sheets; for customizing lessons. III-3, p.7.
Idiom-of-the-week. III-1, p.5.
Imaginary biographies; used in classroom or tutoring work. III-4, p.10.
Listening to students as key to good teaching. III-5, p.12.
Remembering students' names. III-3, p.7.
Sharing a classroom with daytime students; one teacher's experience. III-4, p.10.
Taping radio announcements for listening. III-4, p.10.
Wall adhesives. III-3, p.7.

Minigrants program

Announcing '94 Minigrants. III-5, p.14.
Applying for a grant. A sample application. III-2, p.9.
Awardees for 1993 named. III-2, p.1.
Reports from '93 Minigrants award winners: III-1, p.6; III-2, p.8; III-4, p.4; III-5, p.11; III-6, p.10.

Puzzles

Dictionary puzzle 2 III-3, p.3
Everyday actions. Multi-level crossword puzzle. III-6, p.4.

Occupations, multi-level word matching. III-2, p. 2.
Occupations, crossword puzzle and word search. III-2, p.6 & 7.
Team sports, a crossword puzzle. III-1, p.3.
The U.S. school system; a crossword puzzle. III-5, p.8.

Reading & literacy

"Books-in-Camp," a portable library for migrant workers. III-1, p.6.
Dictionary game. III-3, p.8.
The "Language Experience" story. III-6, p.11.

See also: **Group activities**

Reviews: On the market

Insights for Today: A High-Beginning Reading Skills Text, by Lorraine C. Smith and Nancy Nici Mare (Heinle & Heinle Publishers). III-1, p.9.
LifePrints: ESL for Adults, by Robert Ventre Associates (New Readers Press) Book 1 reviewed. III-4, p.7.
Look Who's Talking! Activities for Group Interaction. 2nd edition, by Mary Ann Christison and Sharon Bassano (Alemany Press/Regents-Prentice Hall). III-3, p.13.
More Index Card Games and Activities for English, by Raymond C. Clark (Pro Lingua Associates). III-4, p.7.
Stories from the Heart, by Ronna Magy (Linmore Publishing). III-1, p.9.

Tools & techniques for instructors

The "Language Experience" story. III-6, p.11.
Multi-level dictation; an example about the health care issues. III-4, p.8.
Photocopy fever: Six ways to reduce handouts. III-1, p.1.
Tips for tutors about writing. III-1, p.12.
A Video Activity. Using a video camera to give students speaking feedback. III-5, p.11.
Volunteers for in-class support; how some programs use tutors. III-4, p.11
Where to get ESL materials. III-1, p.8.

Writing

Commemorative poems by students. III-5, p.10.
Round robin stories. Group activity. III-1, p.5
Student Incentive Project, students receive a book for each 3 stories they write. III-2, p.8
See also: **Group activities**

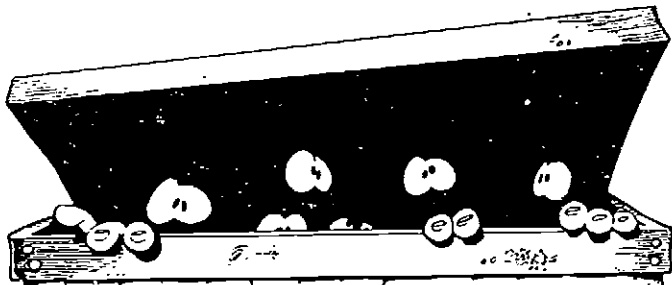

*We can't keep the lid on this
a minute longer!!*

Tired of rummaging through boxes and closets searching for props to demonstrate a concept in class?

Try **Realia Kits For Language Learning!**

- They're stimulating
- They're exciting
- They're fun

(714) 583-0555

Vocational English Language Service

EDUCATIONAL SHOWCASE

Your ESL Connection

Providing ESL/EFL Programs for All Ages

The Largest Collection of ESL Materials
on Display in the Midwest

- Place orders by mail or fax: (313) 680-1052
- UPS delivery in 5 to 10 days of in-stock items
- We meet publisher's prices AND beat the service
- To order or to receive our comprehensive ESL catalog write to:



EDUCATIONAL
SHOWCASE
1334 Wheaton Street
Troy, MI 48083
(313) 680-0860

LifePrints

ESL FOR ADULTS



From New Readers Press

This exciting set of core instructional materials for adults and young adults:

- combines learning to communicate in English with learning the ways and customs of North American culture.
- focuses on developing life skills.
- encourages learners to practice language in situations typical of their everyday lives.

3 LEVELS

- Low-beginning
- High-beginning
- Low-intermediate

4 COMPONENTS

- Student Book
- Teacher's Edition
- Teacher's Resource File
- Audiotape

Developed By Robert Ventre Associates with consulting editors Allene G. Grognet of the Center for Applied Linguistics and Jo Ann Godo Grandall of the University of Maryland Baltimore

Call 800-448-8878 (Dept. 108)
to receive your FREE LifePrints Sampler

Call TODAY!

Or write to
New Readers Press
Box 131, Dept. 108
Syracuse, New York 13210-0131



Hands-on English

A periodical for teachers and tutors of adult ESL
 P.O. Box 256
 Crete, NE 68333
 USA

BULK RATE
 U.S. POSTAGE
 PAID
 CRETE, NE
 PERMIT NO. 256

ADDRESS CORRECTION REQUESTED

March/April issue

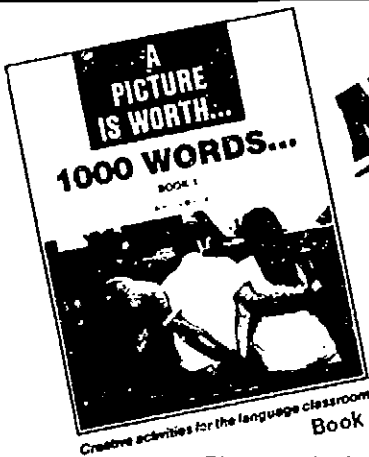

NEW!
includes

by
Anthony Mollica

Teacher's Guide to
A picture is worth... 1000 words...

by
**Anthony Mollica
Julie Ashcroft
Anne-Marie Finger**

\$24⁹⁵ each Add \$4.00 for Shipping

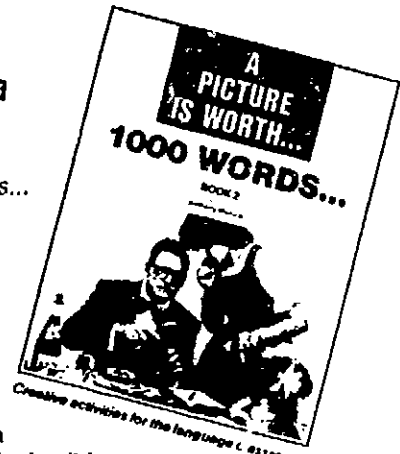

Creative activities for the language classroom
Book 1

Creative activities for the language classroom
Book 2

- ✓ 60 Photographs by North American photographers
- ✓ Each photograph may be photocopied for classroom use

Detachable Line-Masters for Reproduction

- ✓ Excellent visual stimuli for comprehension and discussion
- ✓ Suitable for different grade level and multi-level classes

The *Guide* provides a series of questions to stimulate the students'

- ✓ visual comprehension
- ✓ personal interpretation
- ✓ creativity

at three linguistic levels

- ✓ beginning
- ✓ intermediate
- ✓ advanced

A Teacher's Guide is available in

- English
 - French
 - German
 - Italian
 - Spanish
- (Please specify language.)

éditions SOLEIL publishing inc.

P.O. Box 890 • Lewiston, New York 14092-0890 • Tel./Fax (416) 788-2674



A combined index
of all three years
of *Hands-on English* issues!

We have compiled all of our past articles into one convenient index, to help in locating all those good ideas we've published. We'll send you a copy of this index, FREE, upon request.

Send us some feedback?

As long as you're contacting us, will you include some feedback about the publication? Tell us: What you like or don't like, what kinds of topics you'd like us to cover, how we can help you in your teaching.

This will help us in planning future issues. Thank you! —*Hands-on English*.

Classified ads

To place a classified ad, send your notice of 30 words or less with US \$10 (subscribers get a discount of 50%) to: Hands-on English, P.O. Box 256, Crete, NE 68333 USA. Phone/fax: (402) 826-5426. Toll free call-in: 1-800-ESL-HAND.

Publications:

ORBIS PUBLICATIONS, P.O. Box 4587, Oceanside, CA 92052. Distributor of Bilingual Dictionaries (60 languages) and Publisher of the newest ESL course consisting of several integrated modules. (Free brochure available)

NEW in 1994—Conversation Strategies. Pair and small group activities for developing communicative competence. Students learn expressions to control and use in many everyday situations. \$12.50. *Pro Lingua Associates.* 800-366-4775.

Back issues of *Hands-on English* are now available at US \$4 per copy (this includes shipping costs). Let us know which issues you're missing! See our address above. 🐾

Combined index, Vols. I-III.

Advertisers
Authors
Cultural activities
Editorials
Grammar grab-bag
Group activities
Hints & tips
Minigrants program
Puzzles
Reading & literacy
Reviews
Tools & techniques
Writing

Advertisers

American English Publications. I-4, 5; II-1,2,3,4.
Dominie Press. II-3.
editions SOLEIL publishing. III-1 to 6.
Educational Showcase. I-6; II-1 to 6; III-1 to 6.
Intercultural Press. II-3,4,5,6; III-1, 2.
International Linguistics Corporation. I-3
Linmore Publishing. I-5, I-6
Literacy Volunteers of America. I-3; II-3,4.
New Readers Press. III-3, 5, 6.
Orbis Publications. III-6.
Pro Lingua Associates. II-3,4,5,6. III-1, 2, 6.
Vocational English Lang. Svc. III-6.

Authors

Anderson, Bobbie. "Conversations about death." II-5, p.2.
Armstrong, Fiona. "One question interview." II-1, p.6.
Best, Linda. "Directing students to evaluate their own work." I-2, p.8.
"Freewriting—getting the ideas out." I-3, p.9.
"Scribes help students to learn." I-1, p.10.
Campbell, Karen. "Mapping for vocabulary." I-1, p.5
"More about mapping." I-2, p.12.
Brody, Jane. Minigrants award winner: "Brighter Horizons Student Incentive Project." III-2, p.8.
Brown, Jennifer. "The apartment building— who lives where?" I-4, p.6.
Curlee, Karen. Tips for tutors about writing. III-1, p.12.
Curling, Karen. "Talking about testing... a lighter look at ESL placement testing." II-1, p.8.
Darter, Georgiann. Minigrants award winner: "Family Reading Time." II-5, p.4.
Edwards, Patricia. Minigrants award winner: "Books-in Camp." A family literacy project for migrants. III-1, p.6.
Egbert, Joy. "Shop until you drop!" a cultural activity. III-6, p.6.
Germer, Lucie. "The Class Journal." II-5, p.8.
"Coining, Aspirin and ESL" Cross-cultural health issues. III-6, p.9.

Gex, Judy. "Nine ways to use art in ESL." II-6, p.2.
Grane, Joyce. Minigrants award winner: "The YWCA Pizza Restaurant" activity. III-4, p.4.
Lehmkuhl, Sandra. "In memory of a student." School activities after a tragedy. III-6, p.3.
Lockwood, Sally. "News photo captions," a speaking/reading activity. III-3, p.4.
Lucas, Mary Jane. "Multi-level word matching: Occupations." III-2, p. 2.
Mansour, Selda. Minigrants award winner: "A Video Activity." III-5, p.11.
Novak, Shirley. Minigrants award winner: "The wonderful world of wood." III-5, p.6.
Parlato, Sal. "Ellis Island." a poem. III-5, p.10.
"Limerick Latin." a poem. III-2, p. 5.
"Teach me," a poem. III-3, p. 10.
Rhodes, Michelle. "Creature Feature." Using the verb *have*. II-6, p.5.
Schadewald, Bernadette. Minigrants award winner: "Snapshots in English." II-6, p.8.
Scott, Dianne E. Minigrants award winner: "Cooking up Cultures." III-6, p.10.
Smith-Palinkas, Barbara. Minigrants award winner: "ESL Yearbook Project." II-5, p.5.
Thorington, Linda. "An American social event: the banquet." I-1, p.9.
Uchitelle, Joan. "English names and nicknames." II-1, p.5.
See also: Hints & tips
Cultural activities & info
An American social event: the banquet. I-1, p.9.
Coining, Aspirin and ESL. Cross-cultural health issues. III-6, p.9.
Commemorative poems; to celebrate class occasions & holidays. III-5, p.10.
Conversations about death. II-5, p.2.
Cooking measurements. II-4, p.4.
Cooking up Cultures. Learning about other cultures through food. II-6, p.10.
English names and nicknames. II-1, p.5.
Famous Americans: an information-gapping activity. I-5, p.1.
Making a pumpkin pie. II-4, p.5.
Nine ways to use art in ESL. II-6, p. 2.
Religions crossword puzzle; ideas for activities. I-2, p.4.
Shop until you drop! III-6, p.6.
Editorials
Are we different or the same? Words for *snow* in different languages. II-5, p.9.
Avoiding stress and "burn-out." II-2, p.1.
Bad sounds? Pronunciation problems are not always solved by practice. III-4, p.12.
ESL is not remedial. Public image of ESL. I-4, p.1.
A helping hand for you. Intro to Hands-on English. I-1, p.1.
Listening to history. Sounds of Russian on U.S. airwaves. I-3, p.1.

Moving blues; the difficulties of readjustment. III-2, p.4.
Myths about learning English; it's not as easy as people think. III-3, p.6.
Official English vs language rights. The 'English Only' debate. I-6, p.10.
On the fringes; adult education remains outside the mainstream. III-5, p.12.
Oops—wrong gesture. Bush in Australia. I-5, p.9.
Promoting democracy. II-1, p.1.
The loneliness of an ESL instructor... II-4, p.9.

Grammar grab-bag

Adjectives: a categories worksheet. I-5, p.8.
Categories word game. I-4, p.2.
Comparatives. "It's different where I come from." II-5, p.6.
Conjunctions: because, in order to, so that. An interview activity. III-3, p.1 & 9.
If/ would construction, 'Let's start a business!' I-2, p.3.
Irregular verbs board game. I-4, p.5.
Modals of ability in past and present. "Now I can, but before I couldn't." II-1, p.4.
Present perfect activity, 'Have you ever eaten pizza?' I-6, p.2.
Present perfect with adverbs of time. "He's been in the news recently." II-3, p.6.
Present perfect with *been*—"The places I've been," a conversation activity. III-4, p.1 & 3.
Present perfect continuous worksheet, 'What have they been doing?' S, p.8.
Relative clauses with *who*. "He's the one who got the gold." II-2, p.4.
Tense review—"I'm going away next week," conversation activity. III-1, p.4.
Using the verb *have*. "Creature Feature." II-6, p.5.
Want + object + infinitive. 'Here's what I want you to do.' I-3, p.8.

Group activities

Cartoon dialogs—an all-skills activity. I-1, p.7.
Controversy cards. A discussion activity. I-2, p.10.
Conversation starters: Talking about sports. II-2, p.5.
Conversation wheel. I-6, p.6.
Discussing the U.S. school system; a reading. III-5, p.1 & 9.
Famous Americans: an information-gapping activity. I-5, p.1.
Find someone—questionnaire. I-3, p.4.
Folktale news reports. Role-playing the characters in popular tales. II-3, p.2.
A friendly interview. Conversation activity, getting to know each other. II-4, p.8.
'Ice-breakers' for new students. I-3, p.3.
Interview for getting to know each other. S, p.5.
Interviewing with one student. S, p.12.
National Geographic as conversation starter. I-4, p.10.

Combined index, Vols. I-III, cont'd.

- News photo captions, a speaking/reading activity III-3, p. 4
- One question interview. A survey-type communication activity. II-1, p.6.
- Photos with feeling. Student-generated stories. I-6, p.4.
- Picture talk. Getting students talking about a picture. II-5, p. 1.
- Restaurant simulation activity: The YWCA "Pizza Restaurant." III-4, p.4.
- Reviewing children's books with adults. A discussion activity. II-3, p.7.
- 'Strip stories'—a challenging listening activity. I-1, p.2.
- See also: **Cultural activities and Reading.**
- ## Hints & tips
- Blank flashcard sheets: for customizing lessons. III-3, p.7.
- 'How-to' lesson by students. II-2, p.9.
- Idiom-of-the-week. III-1, p.5.
- Imaginary biographies; used in classroom or tutoring work. III-4, p.10.
- Listening to students as key to good teaching. III-5, p.12.
- Party games. II-4, p.10.
- Picture stories for conversation. II-3, p.8.
- Poker faced definitions. II-6, p. 10.
- Proverbs. II-3, p.8.
- Remembering students' names. III-3, p.7.
- Retelling a folktale. II-3, p.8.
- Scrabble-crossword. II-1, p.9.
- Sharing a classroom with daytime students; one teacher's experience. III-4, p.10.
- Sharing folktales. II-3, p.8.
- Taping radio announcements for listening. III-4, p.10.
- Telephone technology. II-2, p.9.
- 'Try to speak English' hutton. II-5, p.10.
- Vocabulary jigsaw puzzles. II-6, p. 10.
- Wall adhesives. III-3, p.7.
- ## Minigrants program
- Announcing '94 Minigrants. III 5, p.14.
- Applying for a grant. A sample application. III-2, p.9.
- Awardees for 1992 named. II-2, p.10.
- Awardees for 1993 named. III-2, p.1.
- Q & A about the Mini-grants. I-5, p.12
- Reports from '92 Minigrants award winners: II-5, p.4, 5; II-6, p.8; III-1, p.6; III-2, p.8
- Reports from '93 Minigrants award winners: III-4, p.4; III-5, p.6 & p.11; III-6, p.10.
- ## Puzzles
- About health. Multi-level crossword. S, p.6.
- Citizenship puzzle. Multi-level crossword. I-6, p. 1 & 9.
- A dictionary puzzle. Helping students to become familiar with the features of a dictionary. II-2, p.2.
- Dictionary puzzle 2. III-3, p.3.
- Election issues. Multi-level crossword puzzle about the U.S. elections in '92.
- Everyday actions. Multi-level crossword puzzle. III-6, p.4.
- 4th of July: Word find. I-1, p.8.
- Looking for a job. Multi-level crossword. I-5, p.4.
- Occupations, multi-level word matching. III-2, p. 2.
- Occupations, crossword puzzle and word search. III-2, p.6 & 7.
- Parts of the body. Multi-level crossword puzzle. II-6, p.6.
- Religions crossword puzzle. I-2, p.4.
- Summer picnic. A puzzle about the multicultural background of our common foods. II-1, p. 2.
- Team sports, a crossword puzzle. III-1, p.3.
- The U.S. school system; a crossword puzzle. III-5, p.8.
- World news geography. A crossword puzzle relating current events to the world map. II-4, p.2.
- ## Reading & literacy
- "Books-in-Camp," a portable library for migrant workers. III-1, p.6.
- Dictionary game. III-3, p.8.
- Family reading time. Report on a family literacy project. II-5, p.4.
- The "Language Experience" story. III-6, p.11.
- Read and tell. Reading fluently and conversation. S, p.2.
- Variations on a reading text. I-2, p.9.
- What happens next? Prediction activity. I-5, p.7.
- See also: **Group activities**
- ## Reviews: On the market
- All about English as a Second Language—A Basic Guide to ESL and Bilingual Education* A list of resources. II-1, p.10.
- BESTEL and CELSA*. ESL placement tests. II-1, p.1.
- Crossroads, Book 1 and 2*. Basic text for beginners. II-2, p.12.
- The *ESL Miscellany*. Pro Lingua Associates. I-3, p.2.
- insights for Today: A High-Beginning Reading Skills Text*, by Lorraine C. Smith and Nancy Nici Mare (Heinle & Heinle Publishers). III-1, p.9.
- Just-a-Minute*. Eardley Publications. I-1, p.12
- LifePrints: ESL for Adults*, by Robert Ventre Associates (New Readers Press) Book 1 reviewed. III-4, p.7.
- Look Who's Talking! Activities for Group Interaction, 2nd edition*, by Mary Ann Christison and Sharon Bassano (Alemany Press/Regents-Prentice Hall). III-3, p.13.
- More Index Card Games and Activities for English*, by Raymond C. Clark (Pro Lingua Associates). III-4, p.7.
- A Picture is Worth 1000 Words*. Photos for discussion. II-5, p. 1.
- Stories from the Heart*, by Ronna Magy (Linmore Publishing). III-1, p.9.
- Stories We Brought With Us. Beginning readings for ESL*. II-3, p.9.
- Tales from Around the World. Stories for Whole Language Learning*. II-3, p.9.
- Talk about Trivia. Longman. I-4, p.4.
- Whaddaya Say? Prentice-Hall Regents. I-2, p.2.
- What's the Story? Longman Publishing Group. I-6, p.11
- Word Ways Cubes. Alemany Press. S, p.4.
- ## Tools & techniques for Instructors
- Gadgets, widgets, doohickeys and gizmos. Devices that make teaching easier. II-6, p.4.
- The "Language Experience" story. III-6, p.11.
- Lesson planning—after the fact. II-6, p. 1.
- Multi-level classes; some advice. I-4, p.9
- Multi-level dictation; an example about the health care issues. III-4, p.8.
- Organizing all that ESL stuff. I-2 p.6.
- Photocopy fever: Six ways to reduce handouts. III-1, p.1.
- Please speak English! II-4, p.1.
- Progress chart for ESL students; an informal assessment tool. I-3, p.6.
- Shy students; ideas for teaching. I-3, p.12
- Tips for tutors about writing. III-1, p.12.
- A Video Activity. Using a video camera to give students speaking feedback. III-5, p.11.
- Volunteers for in-class support; how some programs use tutors. III-4, p.11.
- Where to get ESL materials. III-1, p.8.
- Why folktales? II-3, p.1.
- ## Writing
- The *Class Journal*. A notebook which circulates from student to student. II-5, p.8.
- Controlled composition: An accident. I-4, p.8.
- Directing students to evaluate their own work, a checklist. I-2, p.8.
- ESL Yearbook Project. Students produce a class yearbook. II-5, p.5.
- Freewriting—getting the ideas out. I-3, p.9
- Penpals in class. Students write letters to each other. II-2, p.8.
- Commemorative poems by students. III-5, p.10.
- Round robin stories. Group activity. III-1, p.5.
- 'Scribes' help students to learn. I-1, p. 10
- Student Incentive Project; students receive a book for each 3 stories they write. III-2, p.8.
- See also: **Group activities.**

Index to articles in *Hands-on English*, Volume I.

Adjectives

A categories worksheet. I-5, p.8

Advertisers

American English Publications. I-4, I-5

Educational Showcase. I-6

International Linguistics Corporation. I-3

Linmore Publishing. I-5, I-6

Literacy Volunteers of America. I-3

Assessment:

The ESL student progress chart - an informal assessment tool. I-3, p.6

Authors

Best, Linda:

Directing students to evaluate their own work. I-2, p.8

Freewriting—getting the ideas out. I-3, p.9

'Scribes' help students to learn. I-1, p.10

Brown, Jennifer:

The apartment building—who lives where? I-4, p.6

Campbell, Karen:

'Mapping' for vocabulary. I-1, p.5

More about 'mapping.' I-2, p.12

Thorington, Linda:

An American social event: the banquet. I-1, p.9

Cultural activities:

An American social event: the banquet. I-1, p.9

Famous Americans: an information-gapping activity. I-5, p.1

A religions crossword puzzle; ideas for activities. I-2. p.4

Dilemmas

Multi-level classes. I-4, p.9

A shy student. I-3, p.12

Editorials

ESL is not remedial. Public image of ESL. I-4, p.1

A helping hand for you. Intro to *Hands-on English*. I-1, p.1

Listening to history. Sounds of Russian on U.S. airwaves. I-3, p.1

Official English vs language rights. The English Only debate. I-6, p.10

Oops—wrong gesture. Bush in Australia. I-5, p.9

Games (see also Puzzles)

Categories word game. I-4, p.2

Irregular verbs board game. I-4, p.5

Just-a-Minute guessing game (review). I-1, p.12.

Low-tech 'Storyboard.' I-4, p.5

Word Ways Cubes (review). S, p.4

Grammar:

Adjectives: A categories worksheet. I-5, p.8

'Have you ever eaten pizza?' A present perfect activity. I-6, p.2

'Here's what I want you to do.' *want* + object + infin. I-3, p.8

Irregular verbs board game. I-4, p.5

'Let's start a business!' *If / would* construction. I-2, p.8

What have they been doing? Pres. perf. continuous worksheet. S, p.8

Group work

Cartoon dialogs—an all-skills activity. I-1, p.7

Famous Americans: an information-gapping activity. I-5, p.1

Interview for getting to know each other. S, p.5

'Strip stories'—a challenging listening activity. I-1, p.2

Holidays:

4th of July: Word find. I-1, p.8

Graduation: An American social event: the banquet. I-1, p.9

Presidents' Day: Famous Americans information-gap activity. I-5, p.1

Religious holidays: A religions crossword puzzle. I-2. p.4

Idea file (Ideas on 4x6 cards)

Cartoon dialogs—an all-skills activity. I-1, p.7

'Ice-breakers' for new students. I-3, p.3

Photos with feeling. Student-generated stories. I-6, p.4

Read and tell. Reading fluency and conversation. S, p.2

Variations on a reading text. I-2, p.9

What happens next? Prediction activity. I-5, p.7

If / would construction: 'Let's start a business!' I-2, p.3

Information for contributors

How to submit an article to *Hands-on English*. I-1, p.6

Irregular verbs Irregular verbs board game. I-4, p.5

Mini-grants

Announcement. I-4, p.11

Q & A about the Mini-grants. I-5, p.12

Organizing:

Organizing all that ESL stuff. I-2 p.6

Present perfect: 'Have you ever eaten pizza?' interview. I-6, p.2

Present perfect continuous: What have they been doing? worksheet. S, p.8

Puzzles:

About health. Multi-level crossword. S, p.6

Citizenship puzzle. Multi-level crossword. I-6, p.1 & 9.

4th of July: Word find. I-1, p.8

Looking for a job. Multi-level crossword. I-5, p.4

A religions crossword puzzle. I-2. p.4

Reading

Variations on a reading text. 15 lessons in one. I-2, p.9

'What happens next?' Directed reading-thinking activity. I-5, p.7

Reviews (On the market)

The ESL Miscellany. *Pro Lingua Associates*. I-3, p.2

Just-a-Minute. *Eardley Publications*. I-1, p.12

Talk about Trivia. *Longman*. I-4, p.4

Whaddaya Say? *Prentice-Hall Regents*. I-2, p.2

What's the Story? *Longman*

Publishing Group. I-6, p.11

Word Ways Cubes. *Alemayn Press*. S, p.4

Speaking/Conversation

Controversy cards. A discussion activity. I-2, p.10

Conversation wheel. I-6, p.6

Find someone—questionnaire. I-3, p.4

'Ice-breakers' for new students. I-3, p.3

Interview for getting to know each other. S, p.5

Interviewing with one student. S, p.12

National Geographic as conversation starter. I-4, p.10

'Strip stories'—a challenging listening activity. I-1, p.2

Vocabulary:

'Mapping' for vocabulary. I-1, p.5

More about 'mapping.' I-2, p.12

want + object + infinitive 'Here's what I want you to do.' I-3, p.8

Writing:

Controlled composition: An accident. I-4, p.8

Directing students to evaluate their own work, a checklist. I-2, p.8

Freewriting—getting the ideas out. I-3, p.9

'Scribes' help students to learn. I-1, p.10



Index to articles in Volume II.

Advertisers

American English Publications.
II-1,2,3,4.

Dominie Press. II-3.

Educational Showcase. II-1-6.

Intercultural Press. II-3,4,5,6.

Literacy Volunteers of America. II-3,4.

Pro Lingua. II-3,4,5,6.

Authors

Anderson, Bobbie. "Conversations about death." II-5, p.2.

Armstrong, Fiona. "One question interview." II-1, p.6.

Curling, Karen. "Talking about testing... a lighter look at ESL placement testing." II-1, p.8.

Darter, Georgieann. Minigrants award winner: "Family Reading Time." II-5, p.4.

Germer, Lucie. "The Class Journal." II-5, p.8.

Gax, Judy. "Nine ways to use art in ESL." II-6, p.2.

Rhodes, Michelle. "Creature Feature." Using the verb *have*. II-6, p.5.

Schadewald, Bernadette. Minigrants award winner: "Snapshots in English." II-6, p.8.

Smith-Palinkas, Barbara. Minigrants award winner: "ESL Yearbook Project." II-5, p.5.

Uchitelle, Joan. "English names and nicknames." II-1, p.5.

See also: **Hints & tips**

Cultural activities & info

Conversations about death. II-5, p.2.

Cooking measurements. II-4, p.4.

English names and nicknames. II-1, p.5.

Making a pumpkin pie. II-4, p.5.

Nine ways to use art in ESL. II-6, p.2.

Editorials

Are we different or the same? Words for *snow* in different languages. II-5, p.9.

Avoiding stress and "burn-out." II-2, p.1.

Promoting democracy. II-1, p.1.

The loneliness of an ESL instructor... II-4, p.9.

Grammar grab-bag

Comparatives. "It's different where I come from." II-6, p.6.

Modals of ability in past and present. "Now I can, but before I couldn't." II-1, p.4.

Present perfect with adverbs of time. "He's been in the news recently." II-3, p.6.

Relative clauses with *who*. "He's the one who got the gold." II-2, p.4.

Using the verb *have*. "Creature Feature." II-6, p.5.

Group activities

Conversation starters: Talking about sports. II-2, p.5.

Folktale news reports. Role-playing the characters in popular tales. II-3, p.2.

A friendly interview. Conversation activity, getting to know each other. II-4, p.8.

One question interview. A survey-type communication activity. II-1, p.6.

Picture talk. Getting students talking about a picture. II-5, p.1.

Reviewing children's books with adults. A discussion activity. II-3, p.7.

See also: **Cultural activities** and **Reading**.

Hints & tips

'How-to' lesson by students. II-2, p.9.

Party games. II-4, p.10.

Picture stories for conversation. II-3, p.8.

Poker faced definitions. II-6, p.10.

Proverbs. II-3, p.8.

Retelling a folktale. II-3, p.8.

Scrabble-crossword. II-1, p.9.

Sharing folktales. II-3, p.8.

Telephone technology. II-2, p.9.

'Try to speak English' button. II-5, p.10.

Vocabulary jigsaw puzzles. II-6, p.10.

Humor

Talking about testing. . . (a lighter look at ESL placement testing). II-1, p.8.

Minigrants program

About the Minigrants. II-5, p.6.

Awardees for 1992 named. II-2, p.10.

Reports from Minigrants award winners: II-5, p.4-5, and II-6, p.8.

Puzzles

A dictionary puzzle. Helping students to become familiar with the features of a dictionary. II-2, p.2.

Election issues. Multi-level crossword puzzle about the U.S. elections in '92.

A summer picnic. A puzzle about the multicultural background of our common foods. II-1, p.2.

Parts of the body. Multi-level crossword puzzle. II-6, p.6.

World news geography. A crossword puzzle relating current events to the world map. II-4, p.2.

Reading

Family reading time. Report on a family literacy project. II-5, p.4.

See also: **Group activities**

Reviews: On the market

All about English as a Second Language—A Basic Guide to ESL and Bilingual Education. A list of resources. II-1, p.10.

BESTEL and *CELSA*. ESL placement tests. II-1, p.1.

Crossroads, Book 1 and 2. Basic text for beginners. II-2, p.12.

A Picture is Worth 1000 Words. Photos for discussion. II-5, p.1.

Stories We Brought With Us. Beginning readings for ESL. II-3, p.9.

Tales from Around the World. Stories for Whole Language Learning. II-3, p.9.

Tools & techniques for instructors

Gadgets, widgets, doohickeys and gizmos. Devices that make teaching easier. II-6, p.4.

Lesson planning—after the fact. II-6, p.1.

Please speak English! II-4, p.1.

Why folktales? II-3, p.1.

Writing

The Class Journal. A notebook which circulates from student to student. II-5, p.8.

ESL Yearbook Project. Students produce a class yearbook. II-5, p.5.

Penpals in class. Students write letters to each other. II-2, p.8.

See also: **Group activities**.



Index to articles in Volume III

Here's our annual round-up of Hands-on English articles! (If you like indexes, see p.15 for a special offer.)

Advertisers

éditions SOLEIL publishing. III-1 to 6.
Educational Showcase. III-1 to 6.
Intercultural Press. III-1, 2.
New Readers Press. III-3, 5, 6.
Orbis Publications. III-6.
Pro Lingua Associates. III-1, 2, 6.
Vocational English Lang. Svc. III-6.

Authors

Brody, Jane. Minigrants award winner: "Brighter Horizons Student Incentive Project." III-2, p.8.
Curlee, Karen. Tips for tutors about writing. III-1, p. 12.
Edwards, Patricia. Minigrants award winner: "Books-in-Camp." A family literacy project for migrants. III-1, p.6.
Egbert, Joy. "Shop until you drop!" a cultural activity. III-6, p.6.
Germer, Lucie. "Coining, Aspirin and ESL" Cross-cultural health issues. III-6, p. 9.
Grane, Joyce. Minigrants award winner: "The YWCA Pizza Restaurant" activity. III-4, p.4.
Lehmkuhl, Sandra. "In memory of a student." School activities after a tragedy. III-6, p. 3.
Lockwood, Sally. "News photo captions," a speaking/reading activity. III-3, p.4.
Lucas, Mary Jane. "Multi-level word matching: Occupations." III-2, p. 2.
Mansour, Selda. Minigrants award winner: "A Video Activity." III-5, p.11.
Novak, Shirley. Minigrants award winner: "The wonderful world of wood." III-5, p.6.
Parlato, Sal. "Ellis Island," a poem. III-5, p.10.
"Limerick Latino," a poem. III-2, p. 5.
"Teach me," a poem. III-3, p. 10.
Scott, Dianne E. Minigrants award winner: "Cooking up Culturea." III-6, p.10.

See also: Hints & tips

Cultural activities & info

Coining, Aspirin and ESL. Cross-cultural ESL issues. III-6, p.9.
Cooking up Cultures. Learning about other cultures through food. III-6, p.10.
Commemorative poems; to celebrate class occasions & holidays. III-5, p.10.
Shop until you drop! III-6, p. 6.

Editorials

Bad sounds? Pronunciation problems are not always solved by practice. III-4, p.12
Moving blues; the difficulties of readjustment. III-2, p.4.
Myths about learning English; it's not as easy as people think. III-3, p.6.
On the fringes; adult education remains outside the mainstream. III-5, p.12.

Grammar grab-bag

Conjunctions: because, in order to, so that. An interview activity. III-3, p.1 & 9.
Present perfect with *been*—"The places I've been," a conversation activity. III-4, p.1 & 3.
Tense review—"I'm going away next week," conversation activity. III-1, p.4.

Group activities

Discussing the U.S. school system; a reading. III-5, p.1 & 9.
News photo captions; a speaking/reading activity. III-3, p.4.
Restaurant simulation activity: The YWCA Pizza Restaurant." III-4, p.4.
See also: Cultural activities & Reading.

Hints & tips

Blank flashcard sheets; for customizing lessons. III-3, p.7.
Idiom-of-the-week. III-1, p.5.
Imaginary biographies; used in classroom or tutoring work. III-4, p.10.
Listening to students as key to good teaching. III-5, p.12.
Remembering students' names. III-3, p.7.
Sharing a classroom with daytime students; one teacher's experience. III-4, p.10.
Taping radio announcements for listening. III-4, p.10.
Wall adhesives. III-3, p.7.

Minigrants program

Announcing '94 Minigrants. III-5, p.14.
Applying for a grant. A sample application. III-2, p.9.
Awardees for 1993 named. III-2, p.1.
Reports from '93 Minigrants award winners: III-1, p.6; III-2, p.8; III-4, p.4; III-5, p.11; III-6, p.10.

Puzzles

Dictionary puzzle 2. III-3, p.3.
Everyday actions. Multi-level crossword puzzle. III-6, p.4.

Occupations, multi-level word matching. III-2, p. 2.
Occupations, crossword puzzle and word search. III-2, p.6 & 7.
Team sports, a crossword puzzle. III-1, p.3.
The U.S. school system; a crossword puzzle. III-5, p.8.

Reading & literacy

"Books-in-Camp," a portable library for migrant workers. III-1, p.6.
Dictionary game. III-3, p.8.
The "Language Experience" story. III-6, p.11.

See also: Group activities

Reviews: On the market

Insights for Today: A High-Beginning Reading Skills Text, by Lorraine C. Smith and Nancy Nici Mare (Heinle & Heinle Publishers). III-1, p.9.
LifePrints: ESL for Adults, by Robert Ventre Associates (New Readers Press) Book 1 reviewed. III-4, p.7.
Look Who's Talking! Activities for Group Interaction, 2nd edition, by Mary Ann Christison and Sharon Bassano (Alemany Press/Regents-Prentice Hall). III-3, p.13.
More Index Card Games and Activities for English, by Raymond C. Clark (Pro Lingua Associates). III-4, p.7.
Stories from the Heart, by Ronna Magy (Linmore Publishing). III-1, p.9.

Tools & techniques for instructors

The "Language Experience" story. III-6, p.11.
Multi-level dictation; an example about the health care issues. III-4, p.8.
Photocopy fever: Six ways to reduce handouts. III-1, p.1.
Tips for tutors about writing. III-1, p.12.
A Video Activity. Using a video camera to give students speaking feedback. III-5, p.11.
Volunteers for in-class support; how some programs use tutors. III-4, p.11.
Where to get ESL materials. III-1, p.8.

Writing

Commemorative poems by students. III-5, p.10.
Round robin stories. Group activity. III-1, p.5.
Student Incentive Project; students receive a book for each 3 stories they write. III-2, p.8.
See also: Group activities